



748 *NATRIX*
electric powered

INSTRUCTION MANUAL
& REFERENCE GUIDE



INTRODUCTION

The Serpent Natrix 748e is based on the successful Natrix 748 gaspowered car (worlds TQ and Vice champion) , combining ultimate performance into a single package. The 200mm wide electric powered racing car offers superb handling with the durability of a stronger 200mm car.

The Serpent Natrix 748e is designed to be a world champion, while still being easy to use, assemble, and set up. You are now part of the worldwide network of Serpent drivers, which gives you superior technical support and access to many benefits that only Serpent drivers can enjoy.

The Serpent Natrix 748e offers state of the art specifications and leads the way in 200mm chassis design, using all the knowledge we have from 1/10 and 1/8 scale racing into this design too. Continuously pushing the performance envelope, Serpent's engineers have added many new and innovative features that can help take your Serpent 748-e into the winner's circle.

Enjoy racing !

Team Serpent

INSTRUCTIONS

Serpent's long tradition of excellence extends to the instruction manuals, and this instruction manual is no exception. The easy-to-follow layout is richly illustrated with 3D-rendered full-color images to make your building experience quick and easy. Following the instructions will result in a well-built, high-performance race-car that will soon be able to unleash its full potential at the racetrack.

INSTRUCTIONS, HOW TO USE

The kit includes bags, with bagnumbers, which refer to the same step in the manual. Open only the indicated bag(s) per step and finish that part of the assembly. Remaining parts will be needed later on in the assembly process.

SETUP

In certain assembly steps you need to make basic adjustments, which will give you a good initial setup for your Serpent S120-LTR. Fine-tuning the initial setup is an essential part of building a high-performance racecar like your S120-LTR.

EXPLODED VIEWS AND PARTS LIST

The exploded views and parts lists for the Serpent S120-LTR are presented in the Reference Guide section in the back of this manual. The exploded views show all the parts of a particular assembly step along with the Serpent part number. The parts lists indicate the part number and name of each part for easy reference when ordering.

CUSTOMER SERVICE

Serpent has made a strong effort to make this manual as complete and clear as possible. Additional info may be published in our website: www.serpent.com or you

may ask your dealer or the Serpent distributor for advice, or email Serpent direct: info@serpent.com

The Serpent Facebook, Twitter and Youtube pages give additional means of support and communications.

SAFETY

Read and take note of the 'Read this First section' before proceeding to assemble the car-kit. This car-kit is intended for persons aged 16 or older.

Read this first!

- This is a highly technical hobby product, intended to be used in a safe racing environment. This car is capable of speeds in excess of 80 km/h or 50mph. Please follow these guidelines when building and operating this model.
 - Parental guidance is required when the builder/user of this car is under 16.
 - Follow the building instructions. If in doubt, contact your dealer or importer.
 - Be sure to use the proper tools when assembling the car. Always exercise caution when using electric tools, knives and other sharp objects.
 - Be careful when using liquids like lubrication oil, fuel or glue. Do not swallow.
 - Follow the manufacturer's instruction in case you experience irritation after using the product.
 - Be careful when operating the car. Stay away from any rotating parts such as wheels, gears and transmission. Stay away from motor, engine and exhaust pipe system or speedo during and immediately after use, as these parts may be very hot. We advise to use protective hand gloves.
 - Only operate this car in a safe environment, like a special racing track or a closed parking lot. Avoid using this car on public roads, crowded places or near infants.
 - Before operating this car, always check the mechanical status of the car. Also check that the transmitter and receiver frequencies correspond and are not used by any other racer at the same time. Check that the batteries of the transmitter and receiver- are fully charged.
 - After use, always check all the mechanics of the car. We advise to clean the car immediately after use, and inspect the parts for wear or fractures. Replace when necessary. Do not use water, methanol, thinner or other solvents to clean the car.
 - Empty the fuel tank (depending on model) if needed and disconnect the receiver battery.
 - Store the car in a dry and heated place to avoid corrosion of metal parts.
 - Avoid using this car in wet conditions as the water will cause corrosion on the metal parts and bearings and these parts will cease to function properly.
- If driven in the wet, ensure that all the electric equipment is waterproofed and after use, that all moving parts are dried immediately.

CONTENTS

FRONT DIFFERENTIAL ASSEMBLY	4
REAR DIFFERENTIAL ASSEMBLY	9
TRANSMISSION ASSEMBLY	6
STEERING ASSEMBLY	9
REAR ASSEMBLY	11
FRONT ASSEMBLY	14
RCM SHOCKS ASSEMBLY	19
ELECTRONICS ASSEMBLY	20
REFERENCE GUIDE	22

USING THE MANUAL

Each step contains a variety of numbers, lines, and symbols. The numbers represent the order in which the parts should be assembled. The lines and symbols are described below.

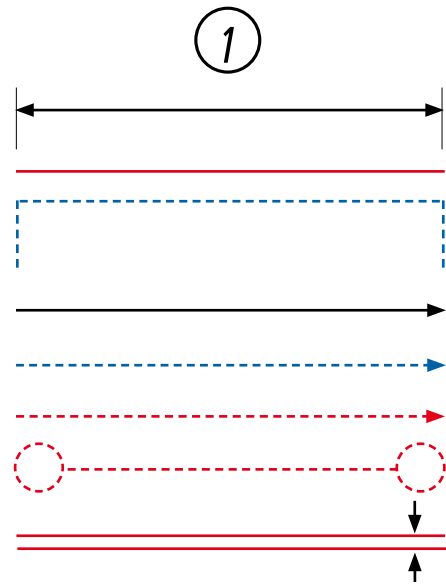

Step number; the order in which you should assemble the indicated parts

Length after assembly

Assembly path of one item into another

Group of items (within lines) should be assembled first

Direction the item should be moved

Glue one item to another

Press/Insert one item into another

Connect one item to another

Gap between two items

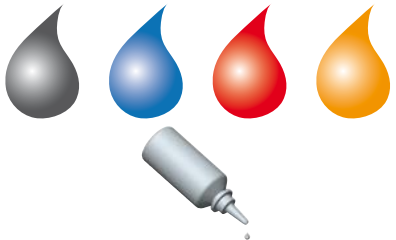

Apply transmission grease (Grey), threadlock* (Blue), CA glue* (Red) or silicone grease (Orange). (*Items not included.)

Apply silicone oil,

ASSEMBLY INSTRUCTIONS

FRONT DIFFERENTIAL ASSEMBLY

STEP
1
BAG
FRONT
DIFF

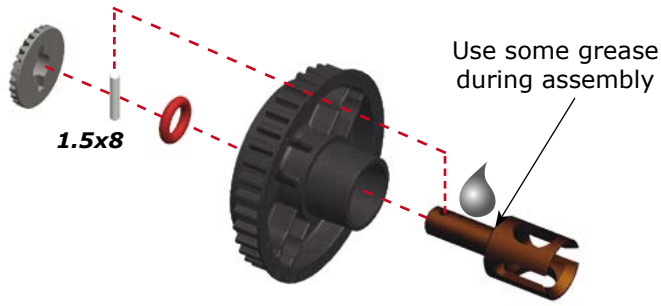

NOTE:

In step 2 to mount the pin, first put the pin in the purpose made slot as shown, and after slide it through the hole in the shaft.



STEP
2

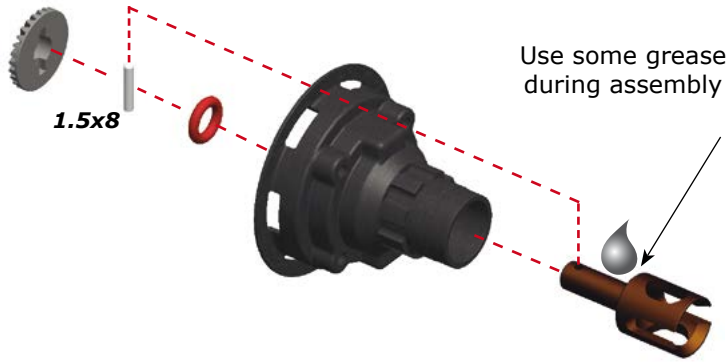

STEP
3

3.1

NOTE:

Add just enough oil to cover the large gear before assembling the small satellite gears and cross pins (step 3.3).



3.2

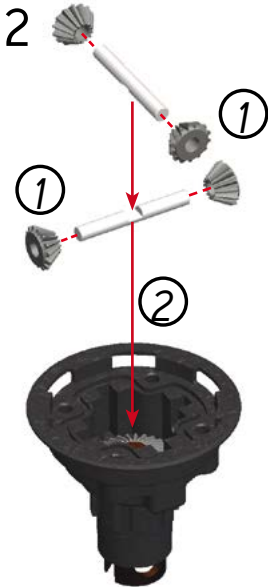

STEP
4

4.1

NOTE:

1) Assemble the o-ring before adding the oil.
2) Add oil so the cross pins are just covered (DO NOT overfill).

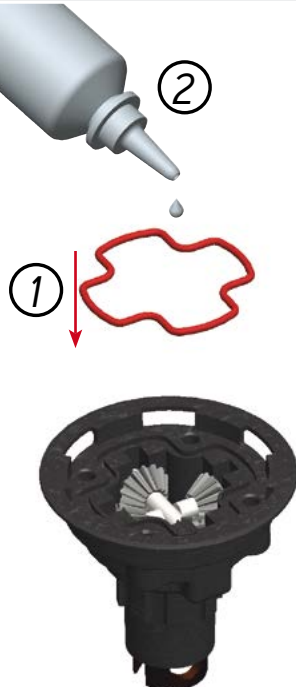

NOTE:

The diff assembled as shown here, should weigh max 17.1 grams



4.2



REAR DIFFERENTIAL ASSEMBLY

STEP
5
BAG
REAR
DIFF

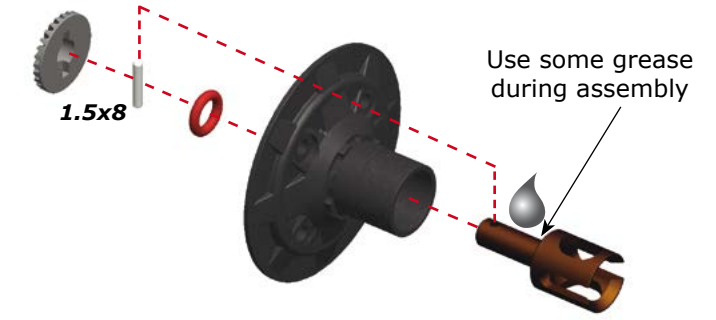

NOTE: Step 5 and 6
To mount the pin, first put the pin in the purpose made slot as shown, and after slide it through the hole in the shaft.



STEP
6

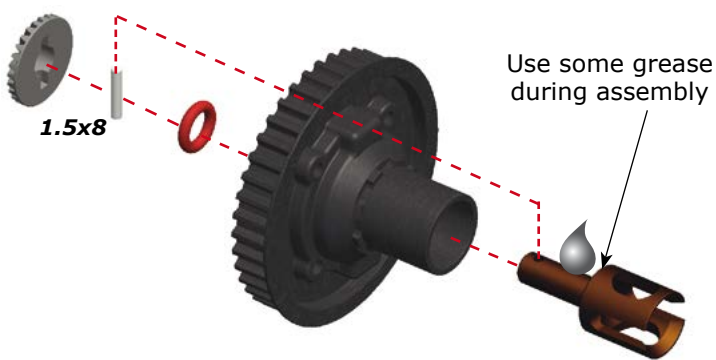

STEP
7

7.1

NOTE:
Add just enough oil to cover the large gear before assembling the small satellite gears and cross pins (step 3.3).



7.2

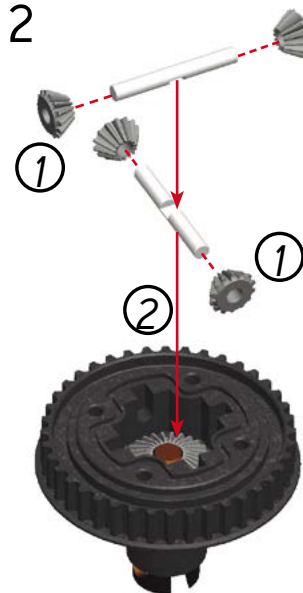

STEP
8

8.1

NOTE:
1) Assemble the o-ring before adding the oil.
2) Add oil so the cross pins are just covered (DO NOT overfill).

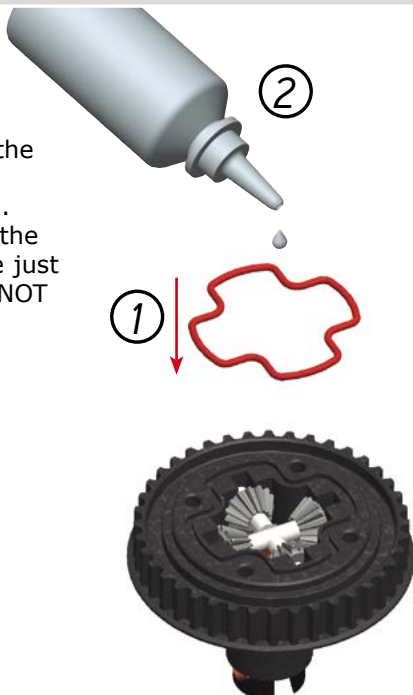

NOTE:
The diff assembled as shown here, should weigh max 19.2 grams



8.2

M2.5x8



CA Glue

STEP
9

To prevent the risk of the carbon fibre splitting in the event of a crash you should apply CA Glue around the chassis' edge as shown in red below.

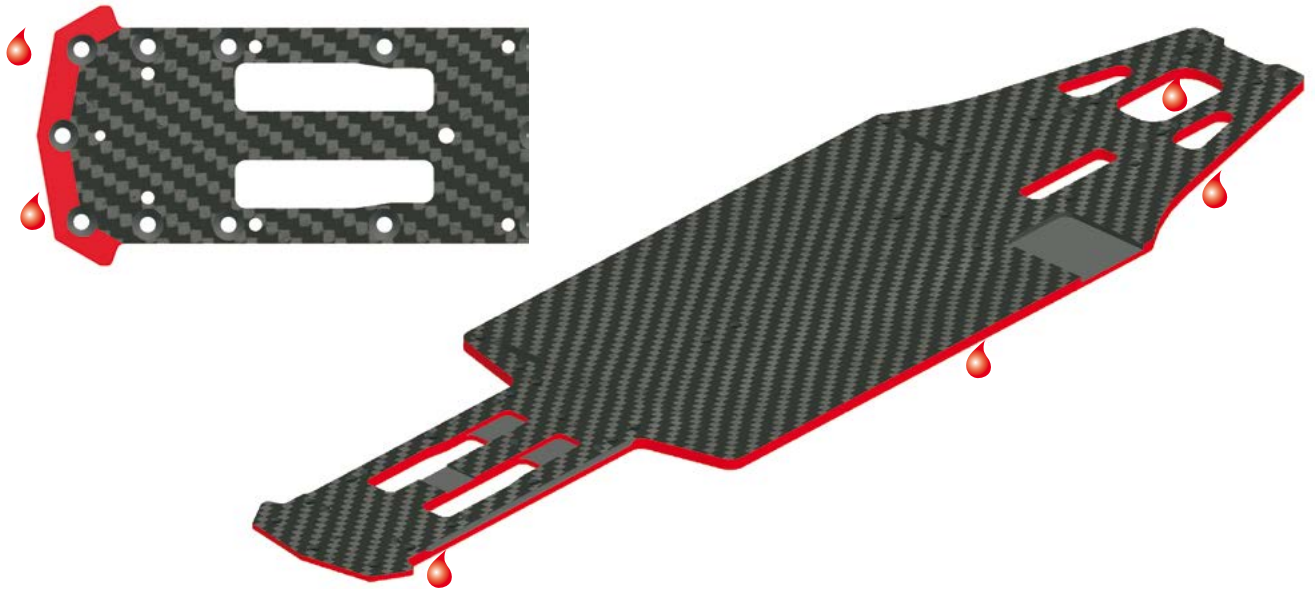

TRANSMISSION ASSEMBLY

STEP
10

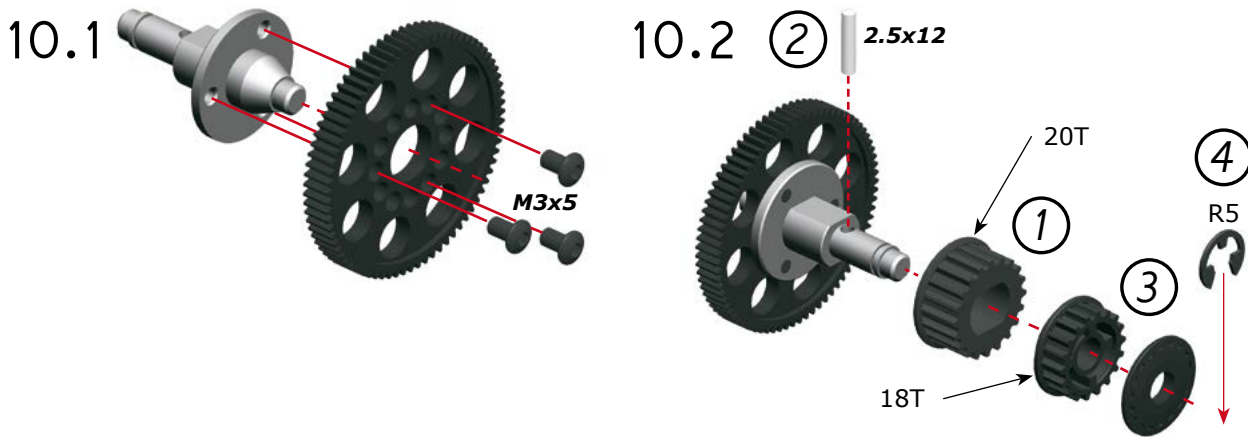

Bag
1

STEP
11

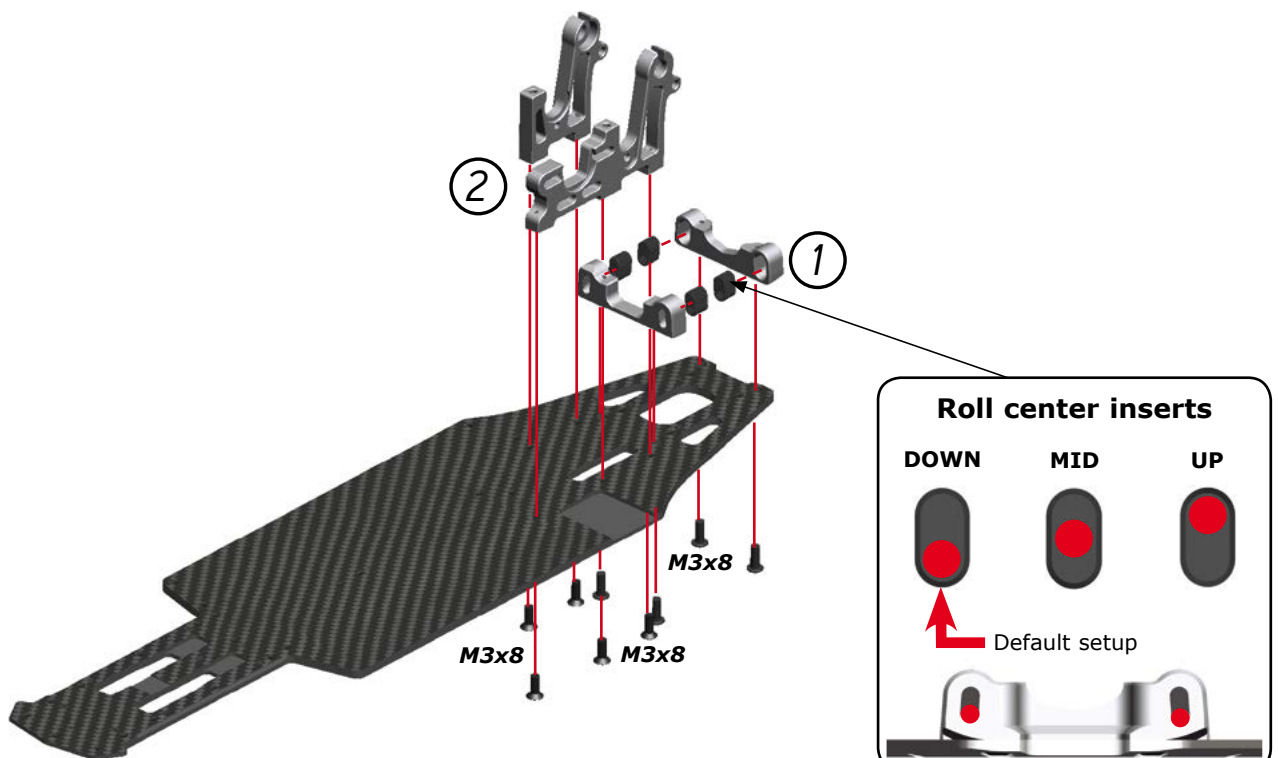

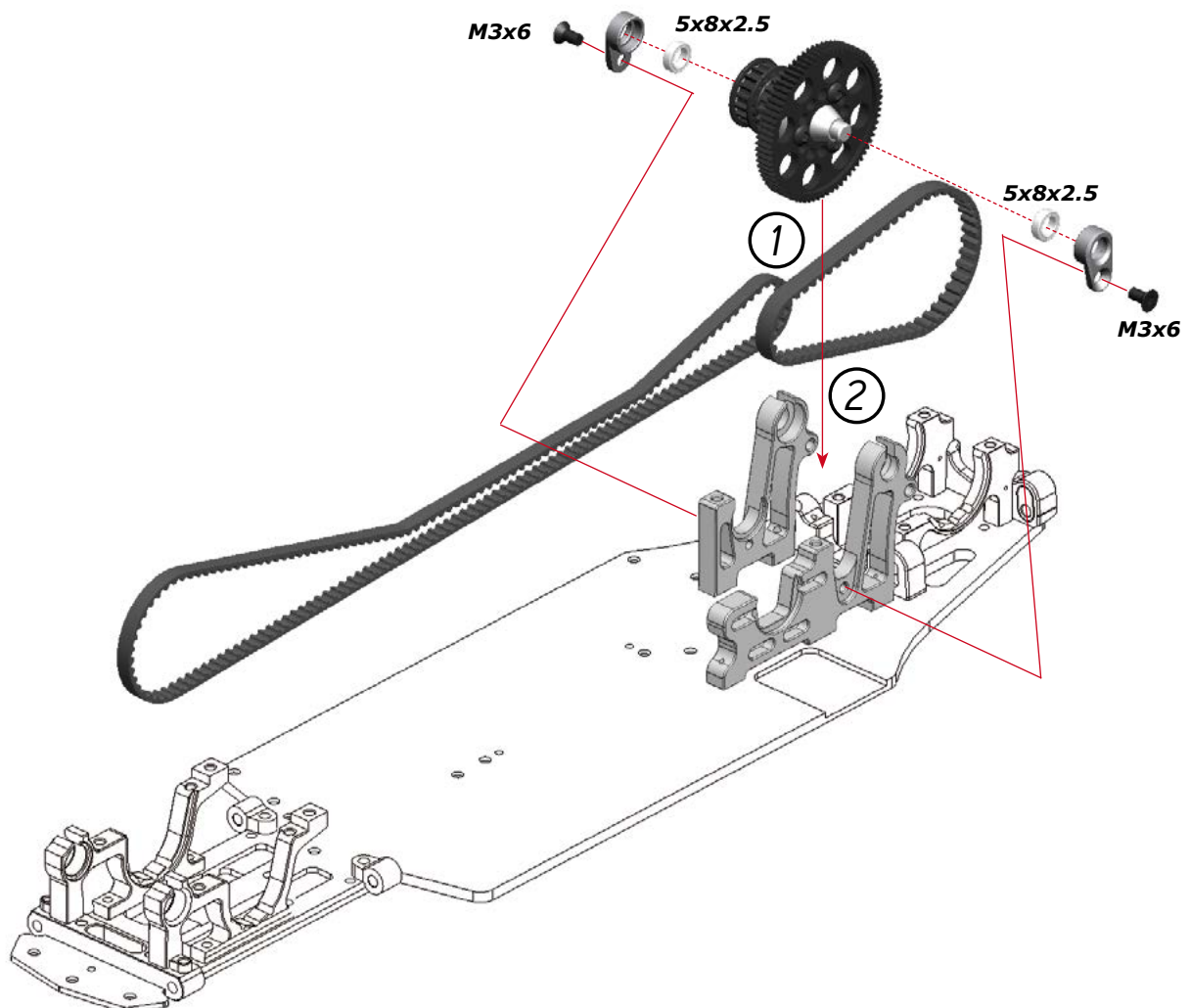
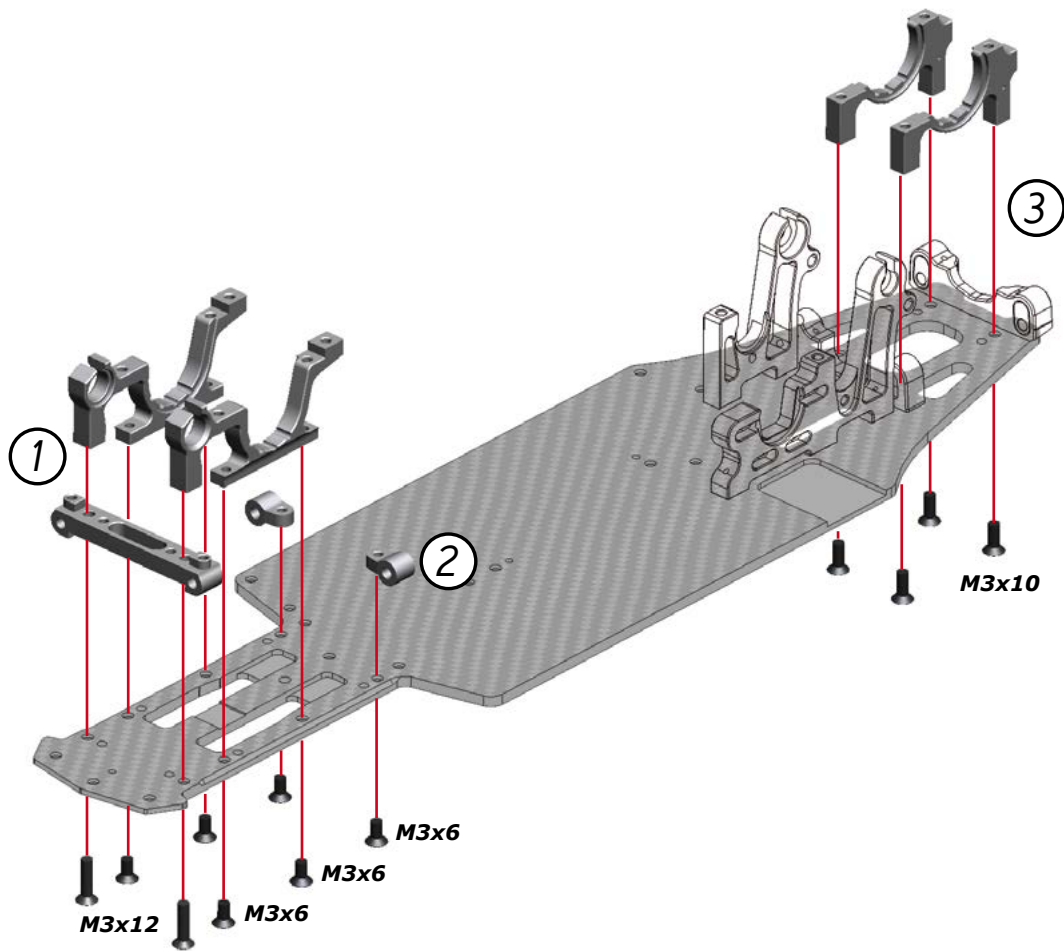

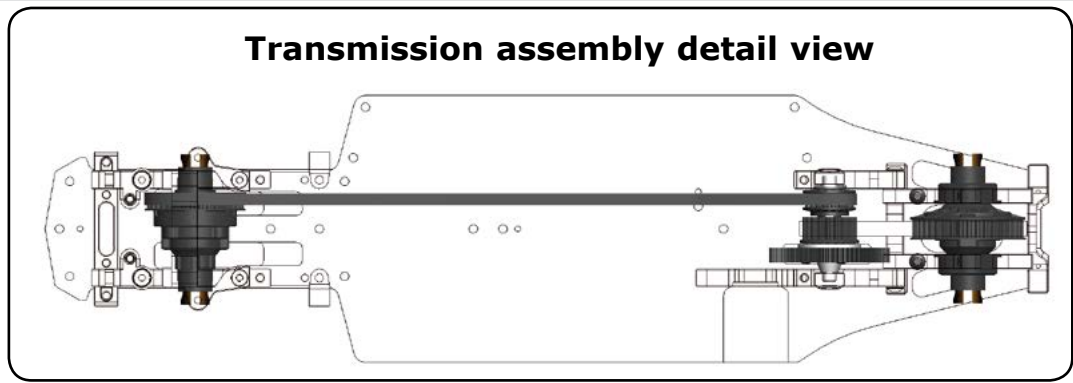
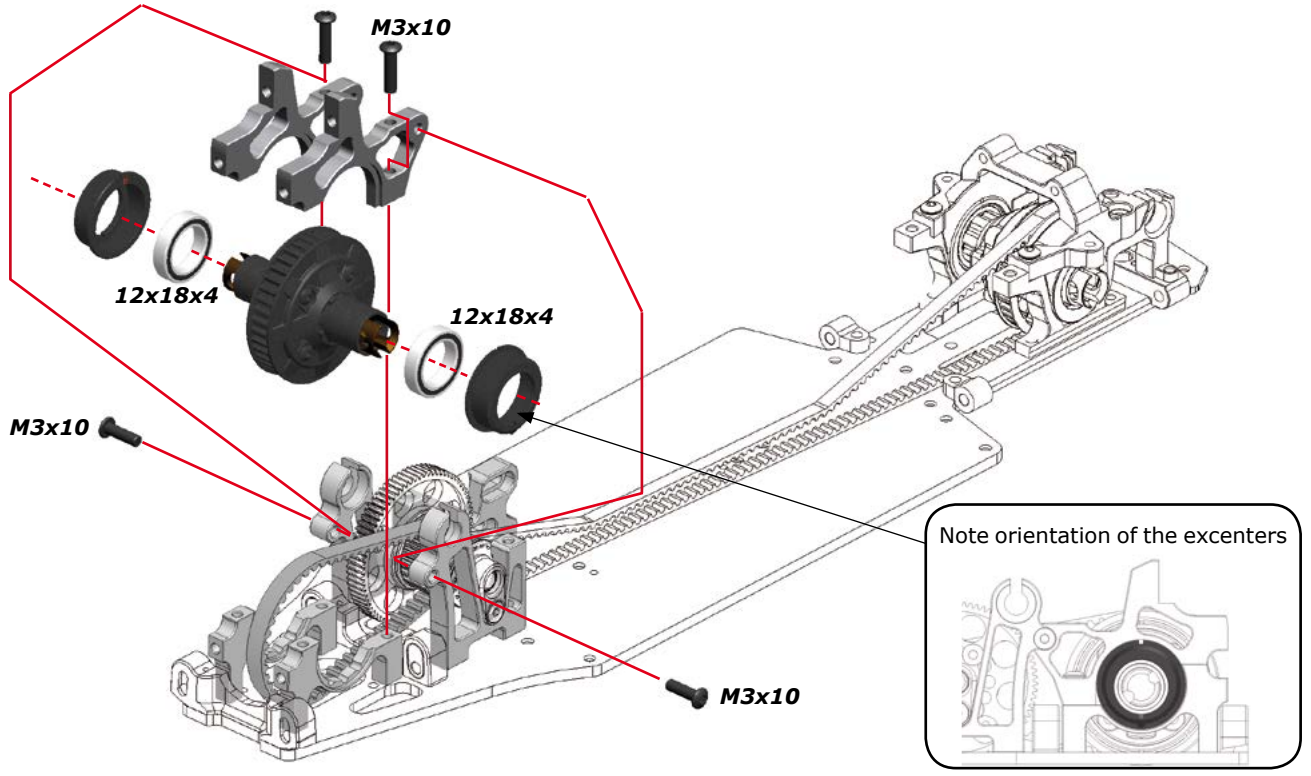
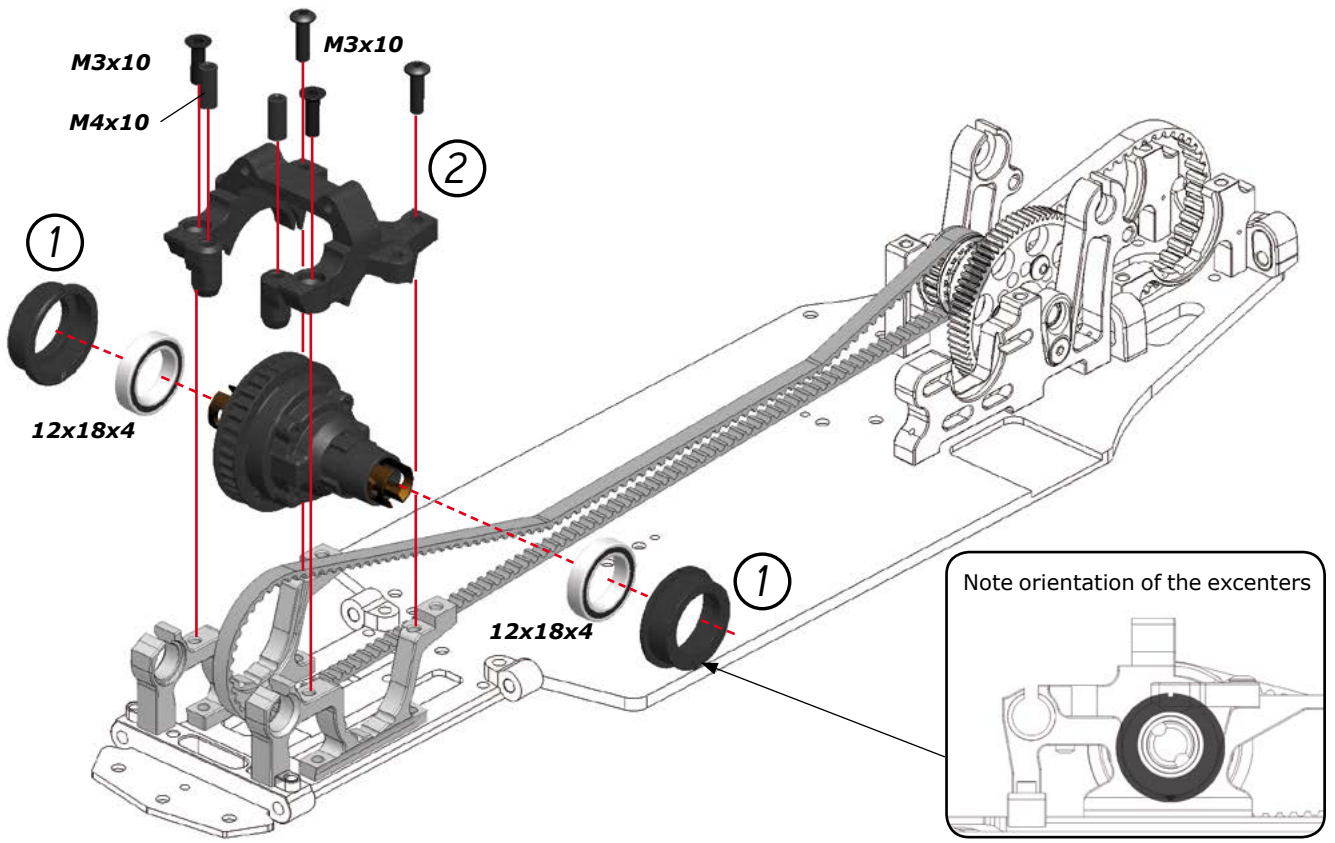

17.4

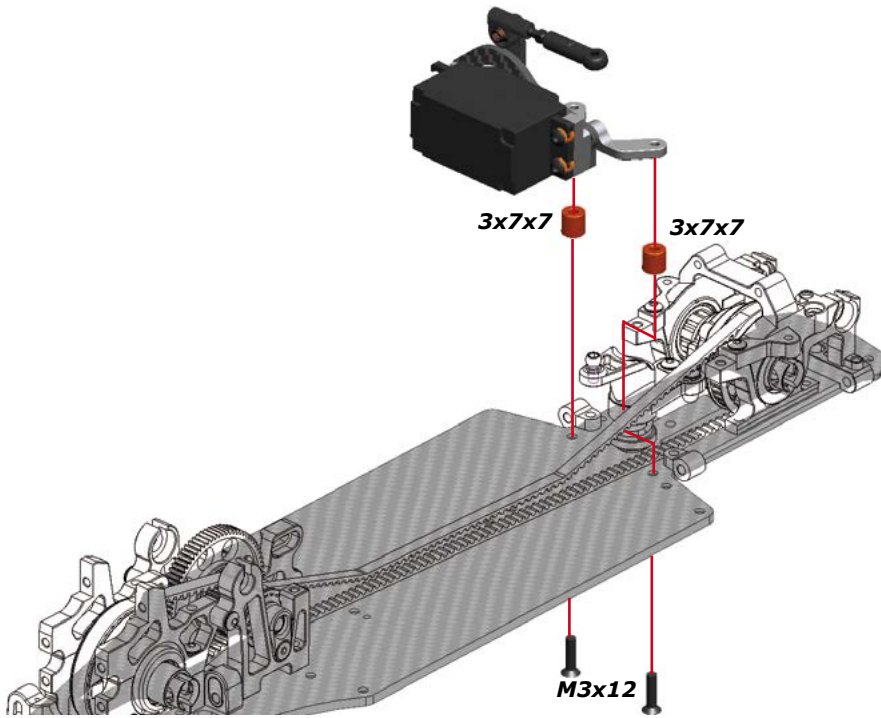

STEP 18

18.2

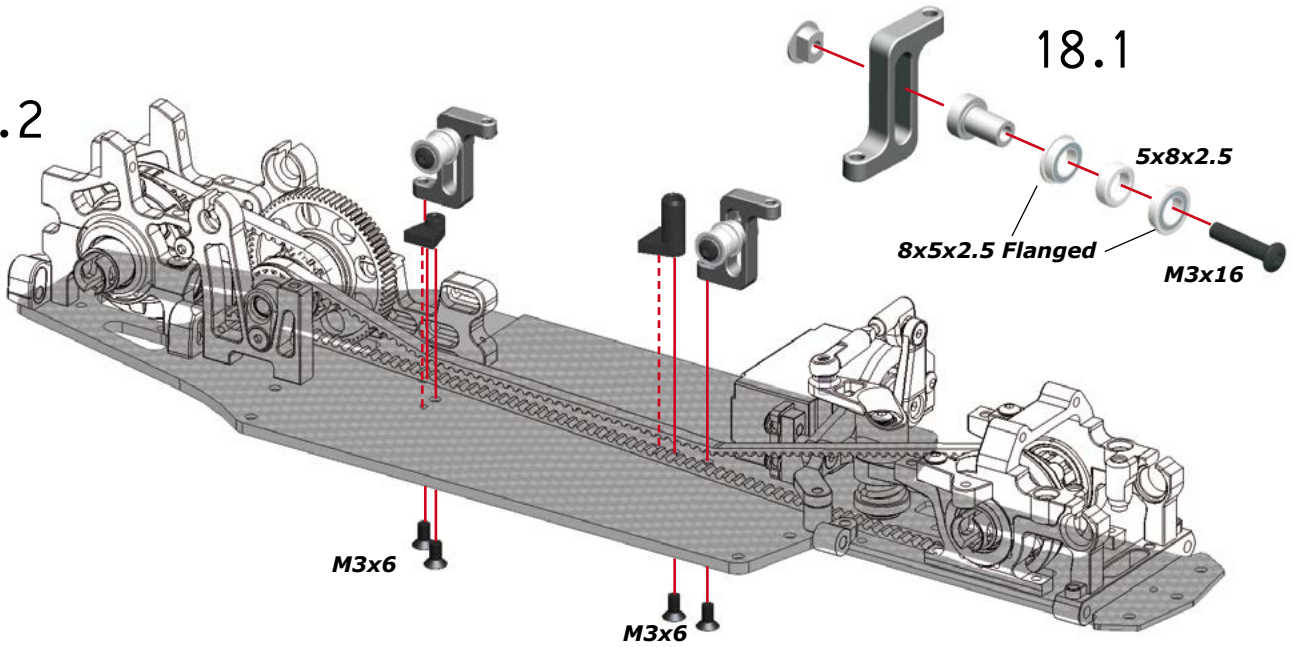

STEP 19

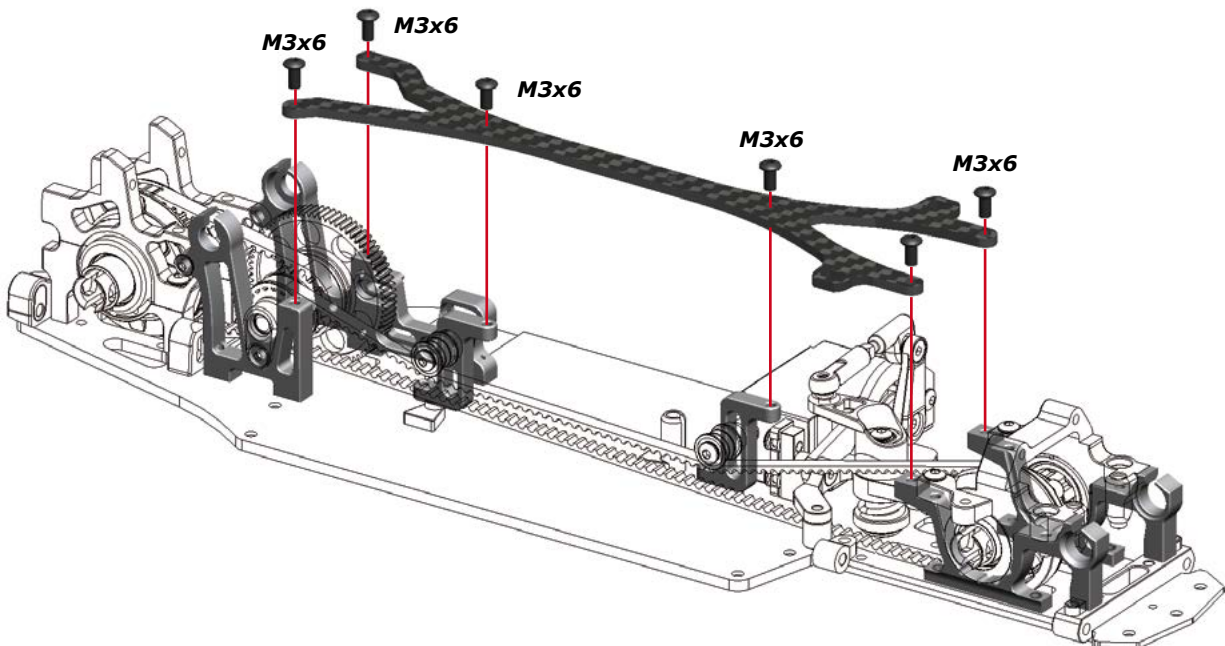

REAR ASSEMBLY

STEP
20

Bag
5

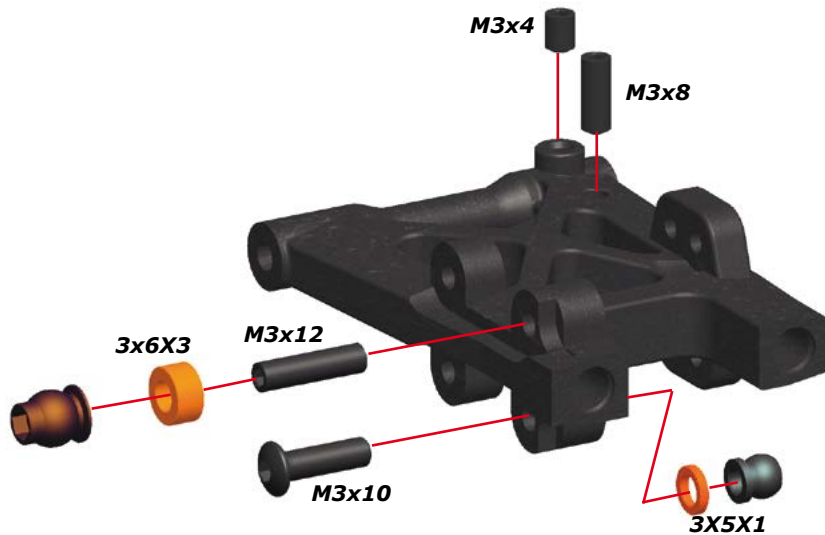

STEP
21

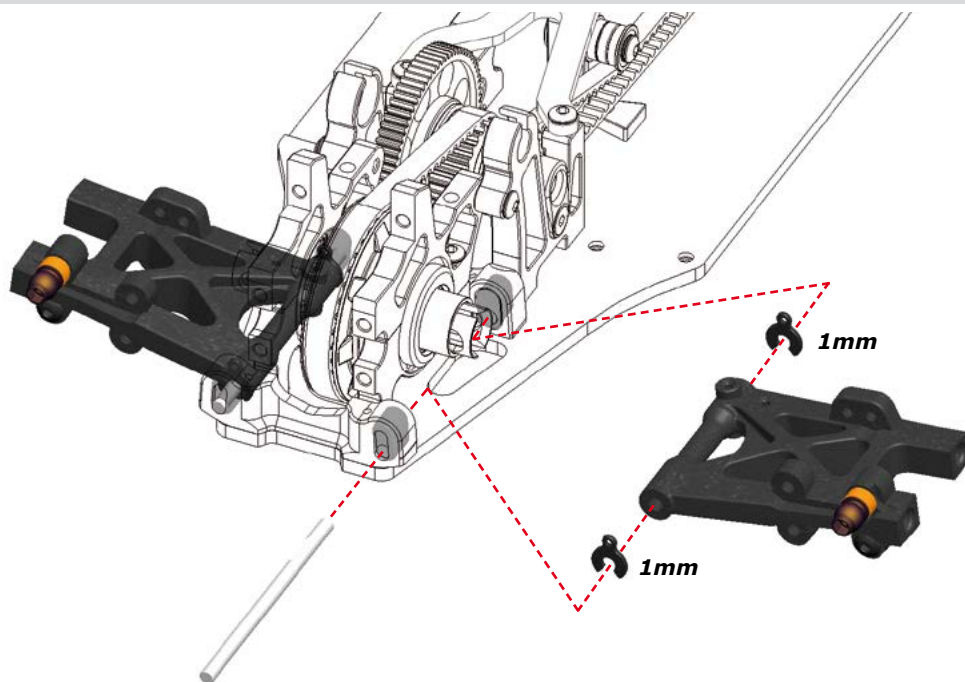

STEP
22

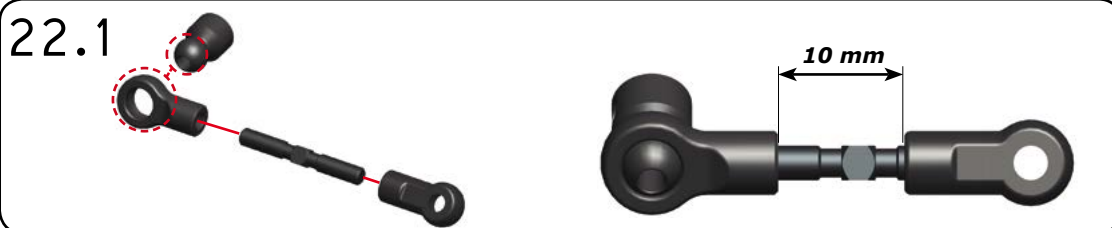

22.2

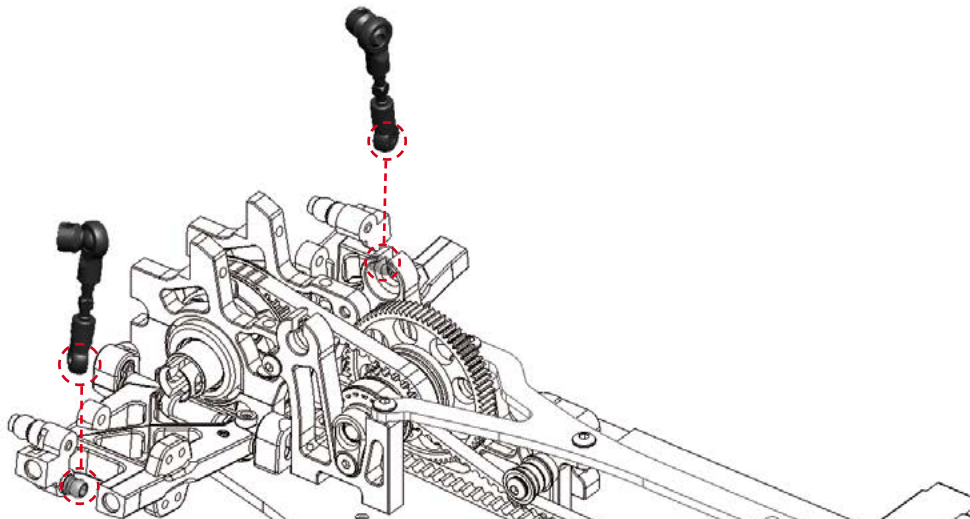

23.1

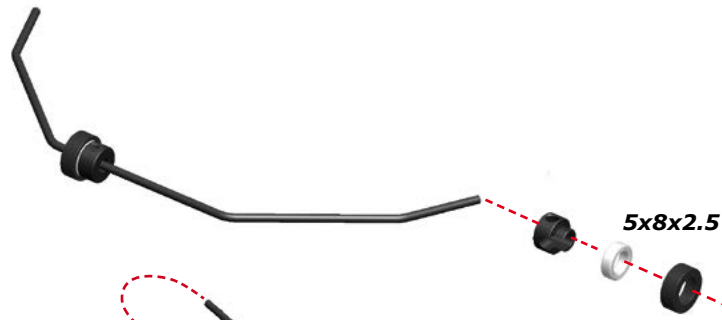

23.2

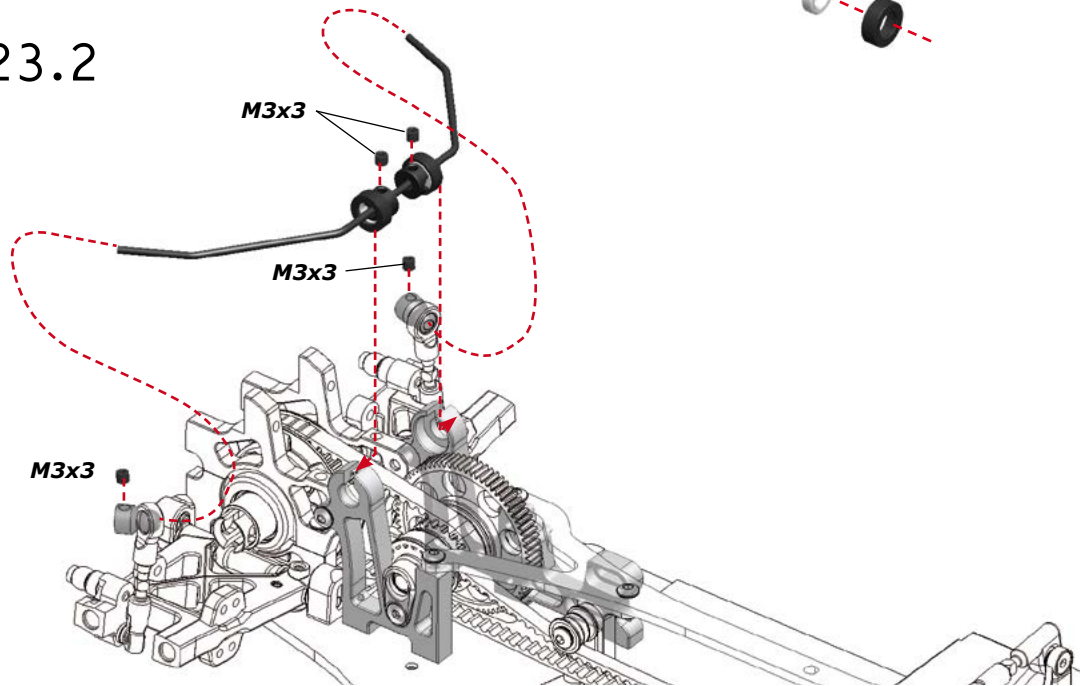

24.1

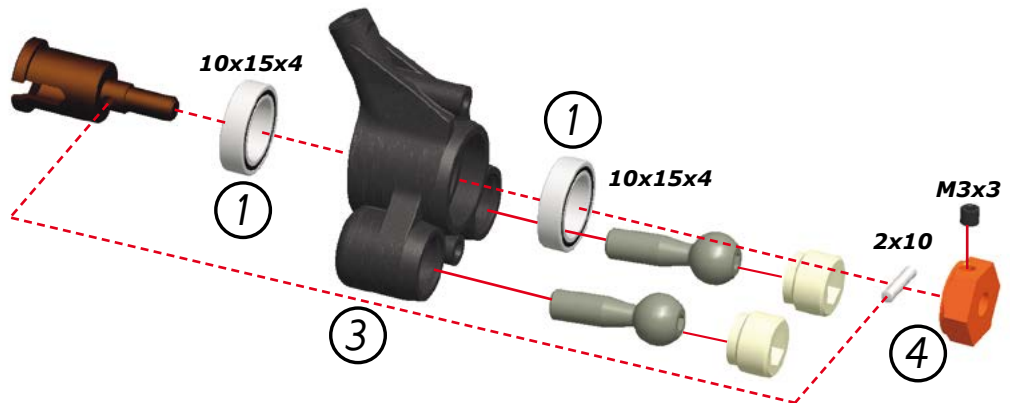

24.2

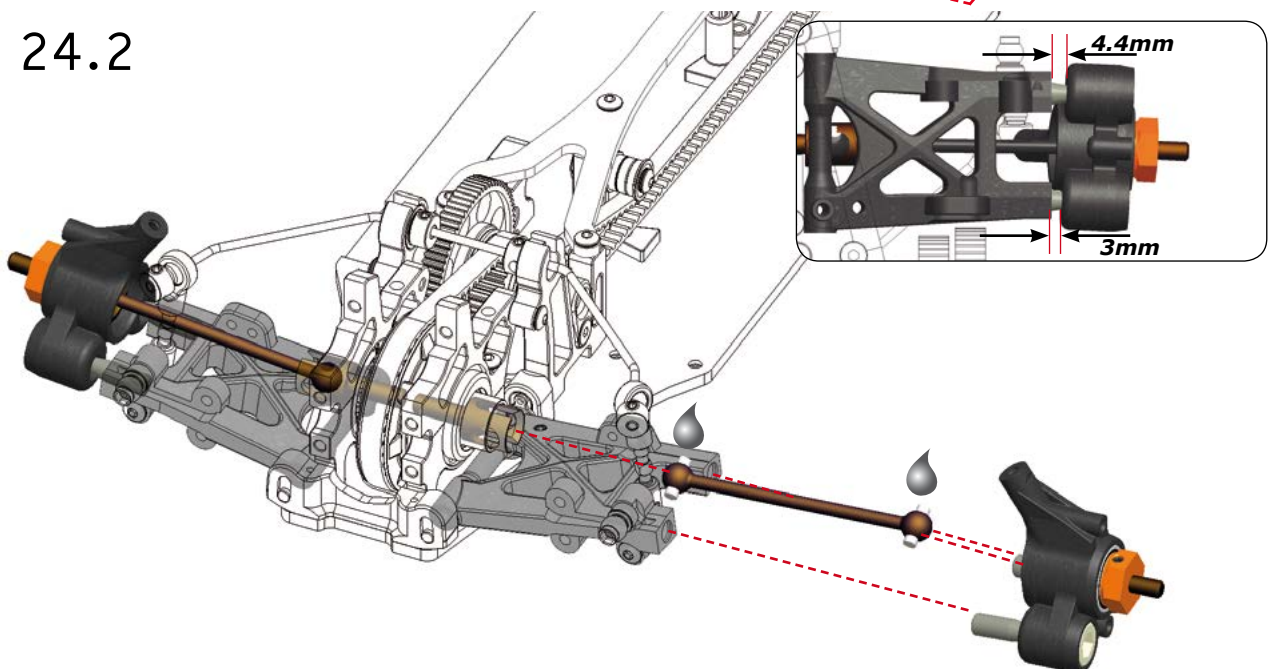

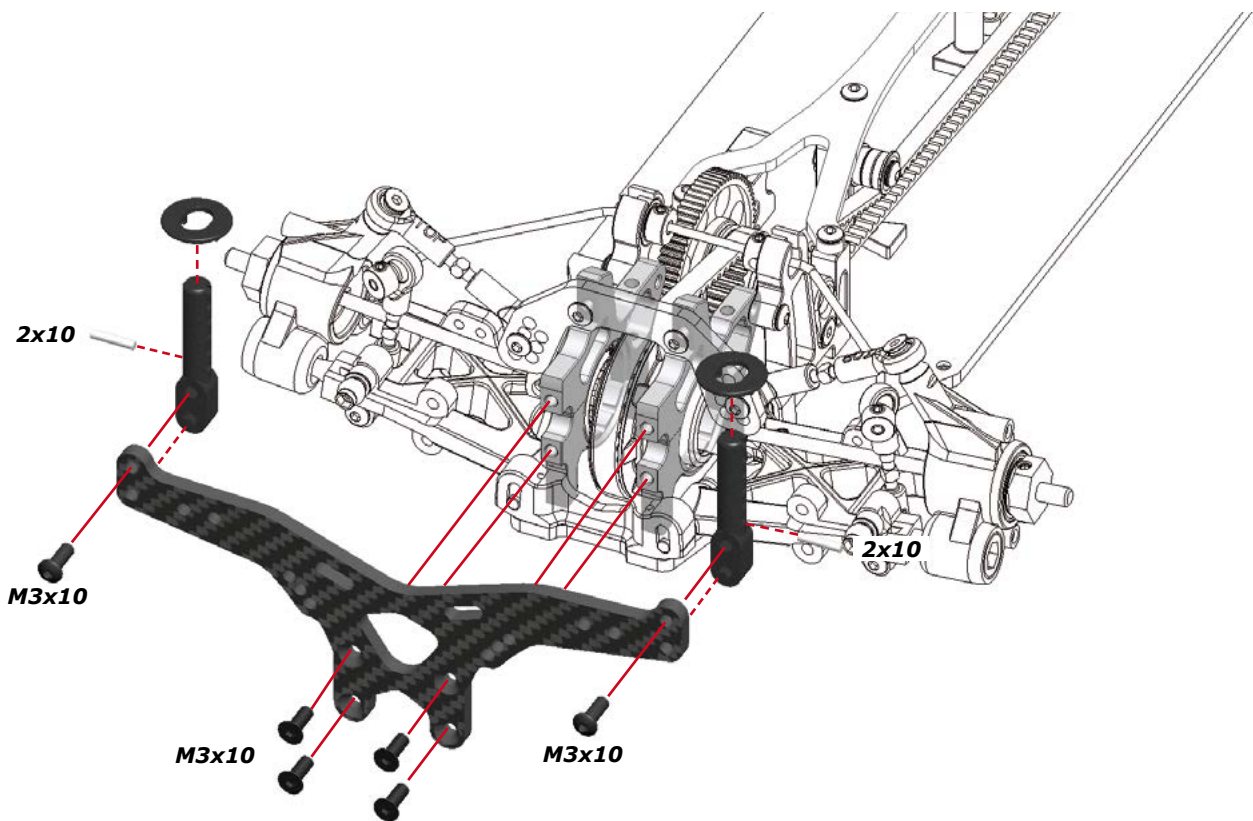
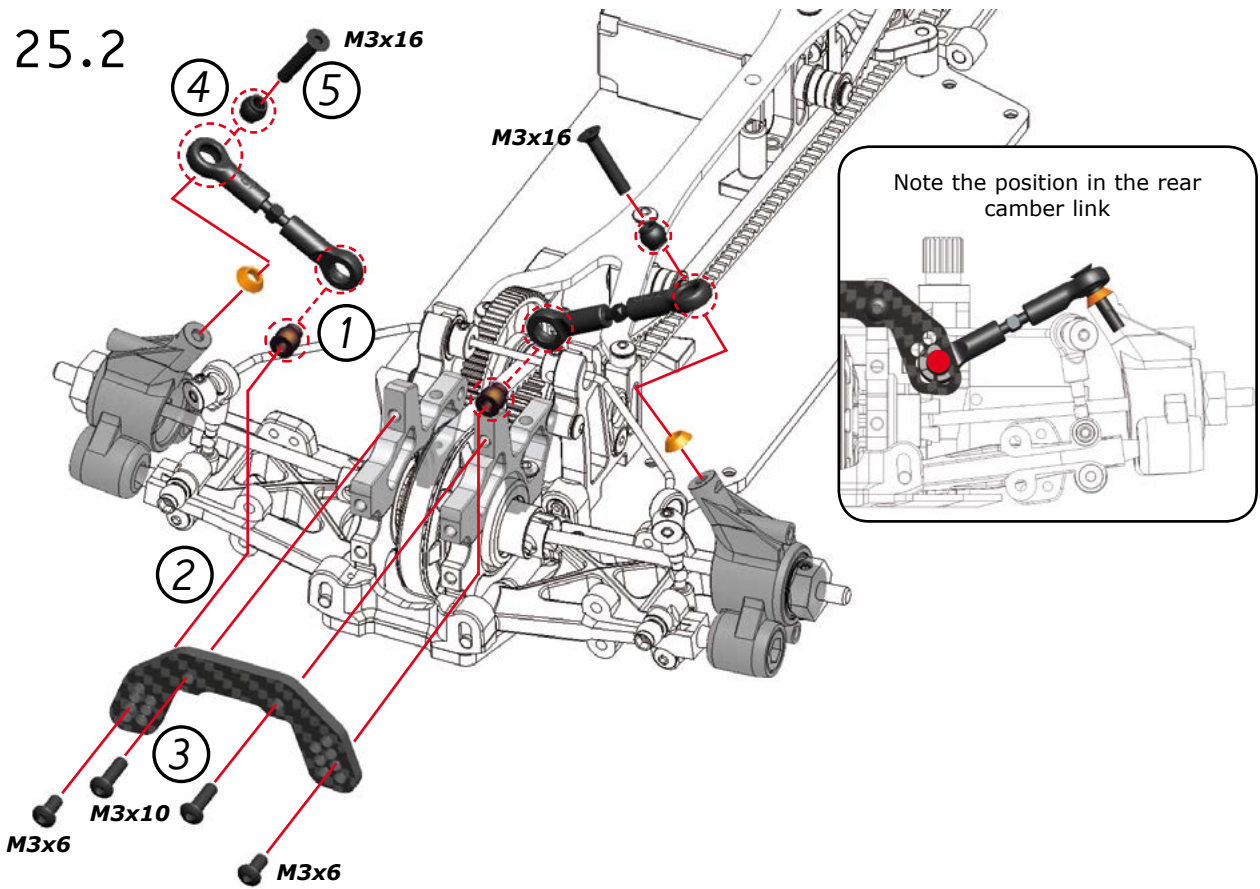
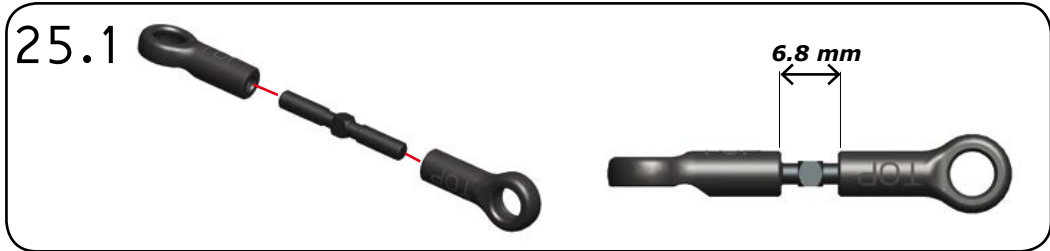

FRONT ASSEMBLY

STEP
27

Bag
7

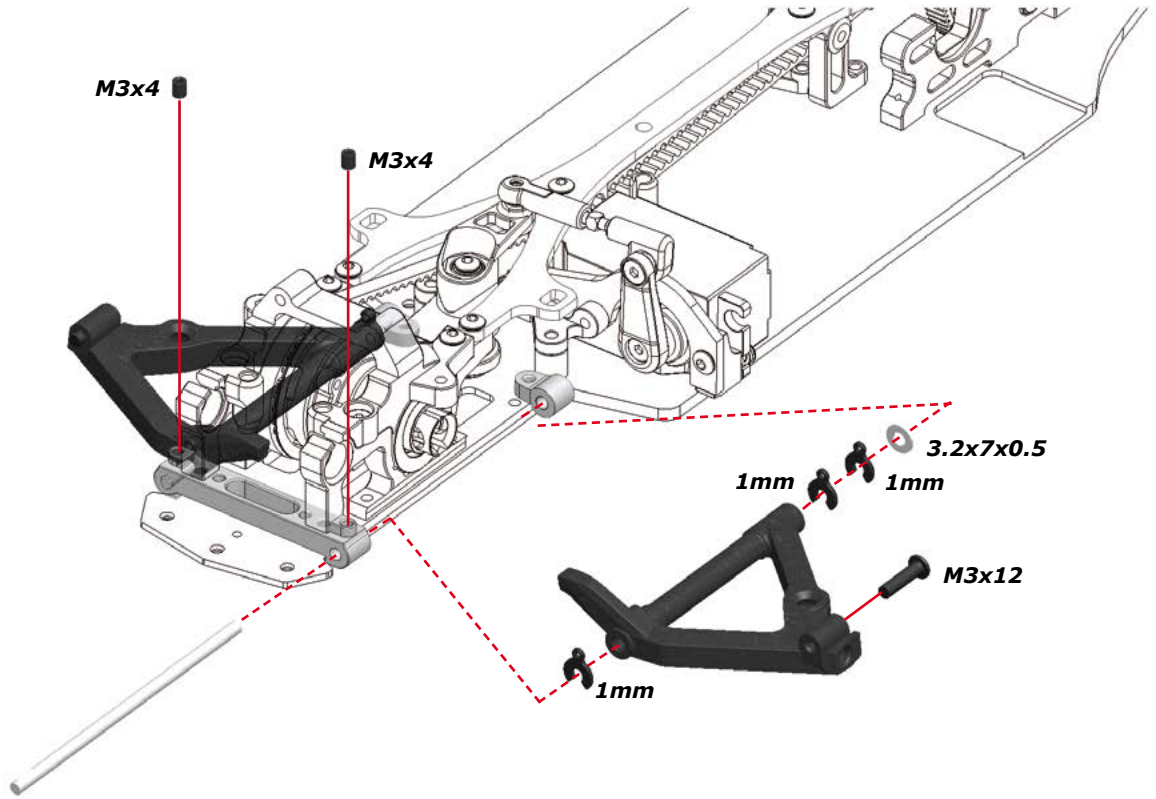

STEP
28

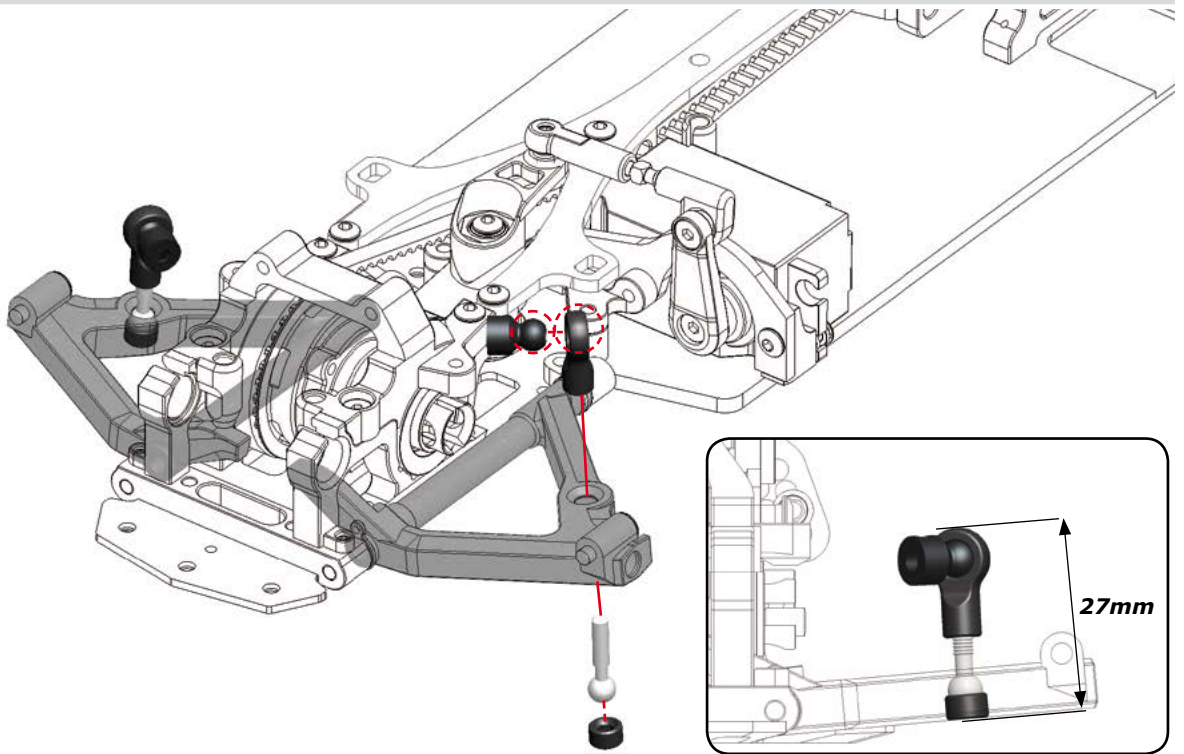

STEP
29

29.1

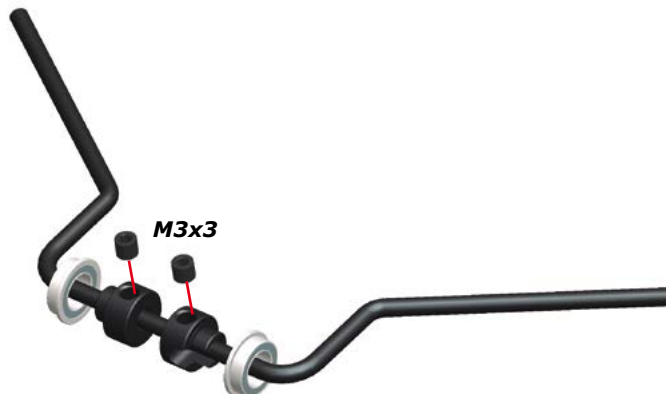

Serpent

Page
14

29.2

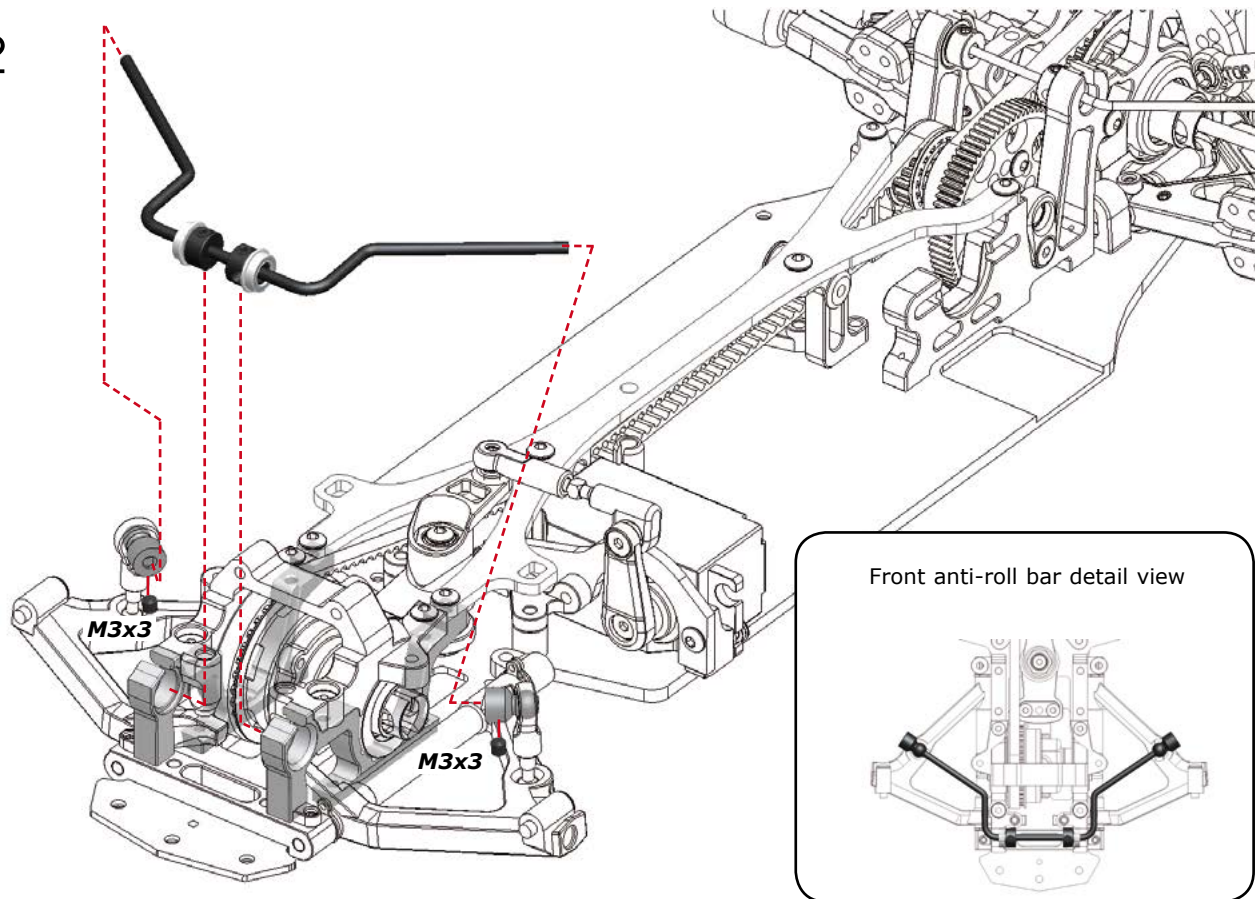

STEP
30

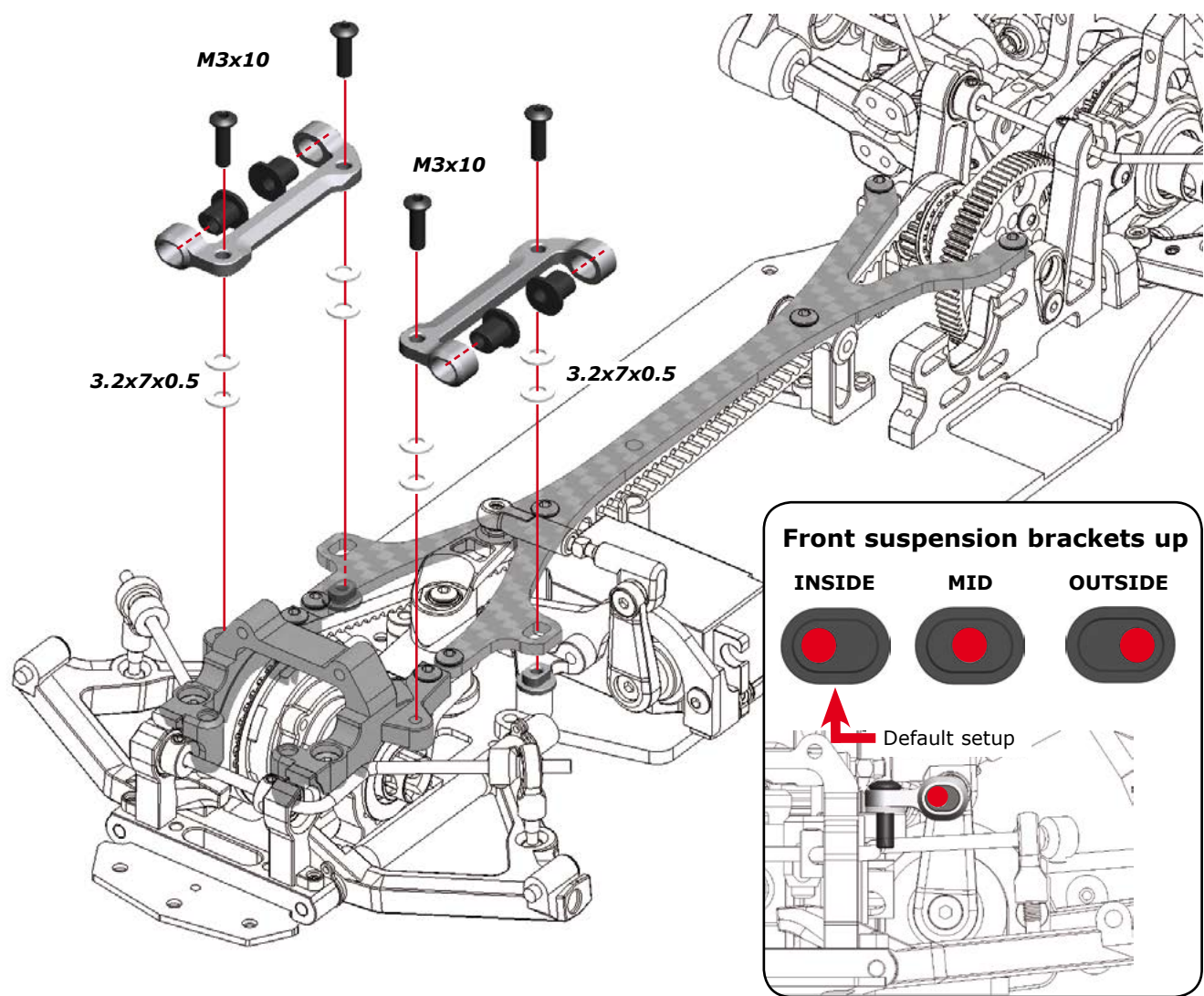

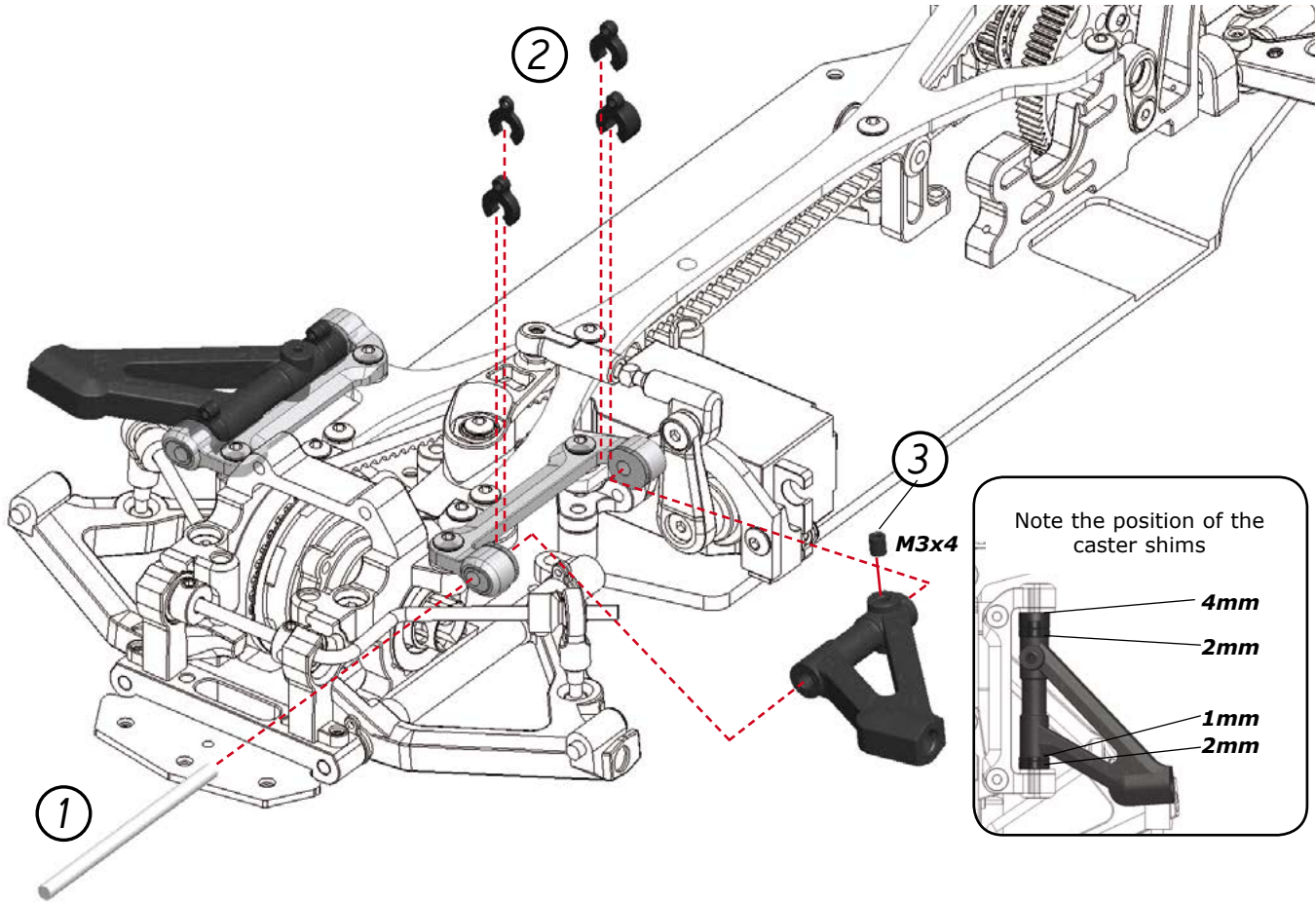

32.1

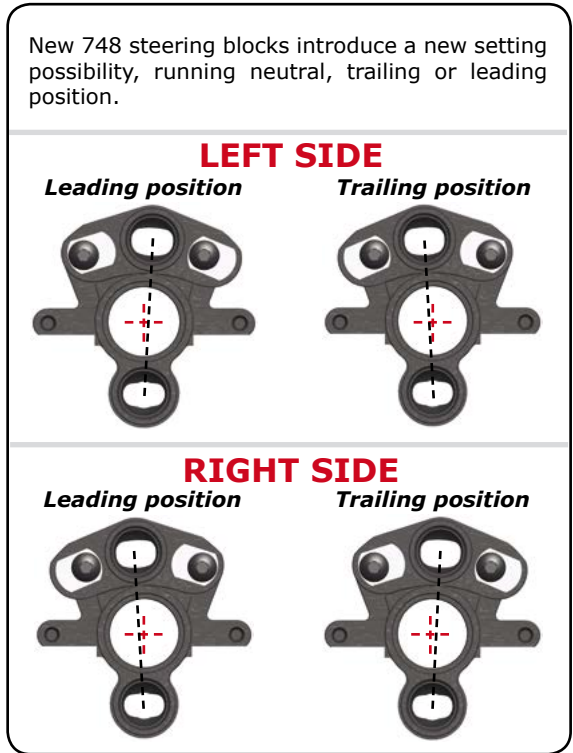
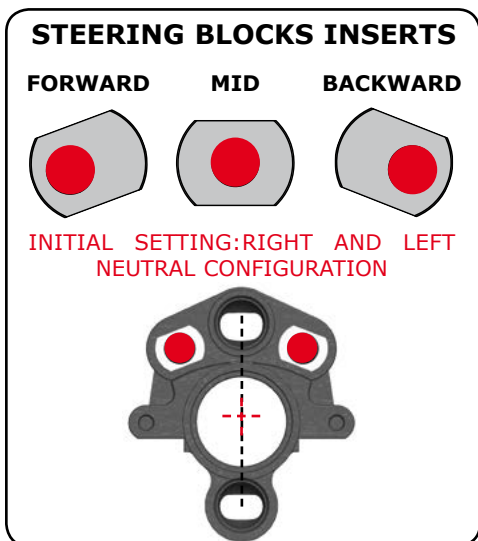
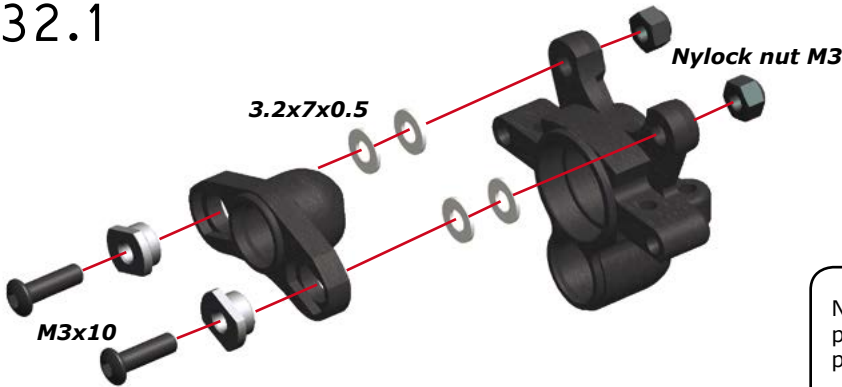

32.2

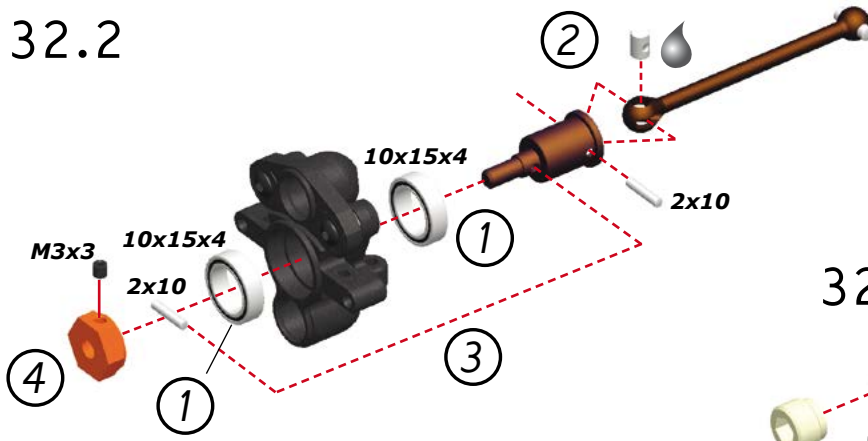

32.3

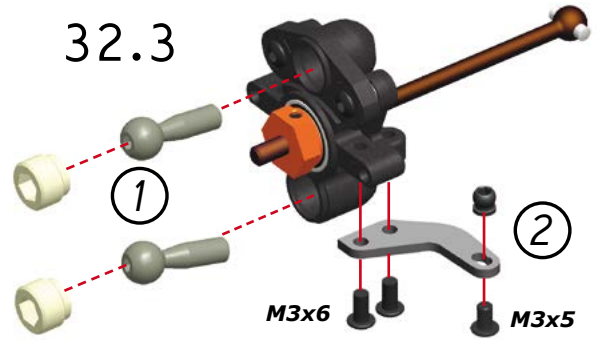

STEP 33

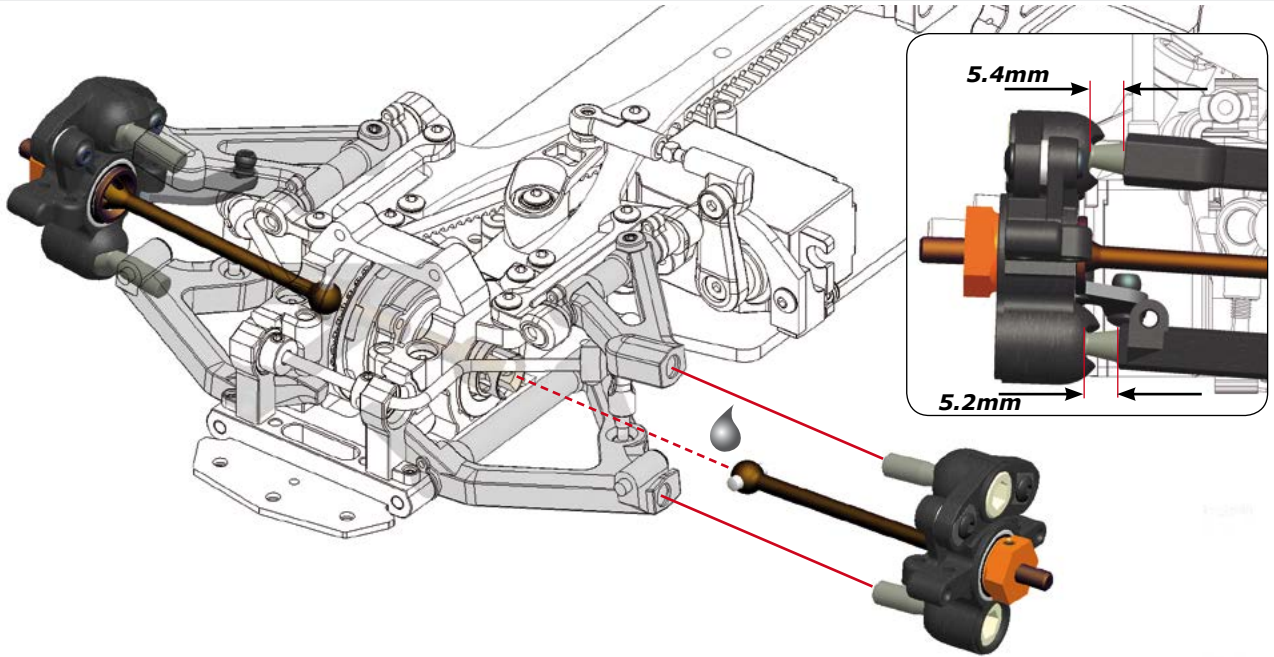

STEP 34

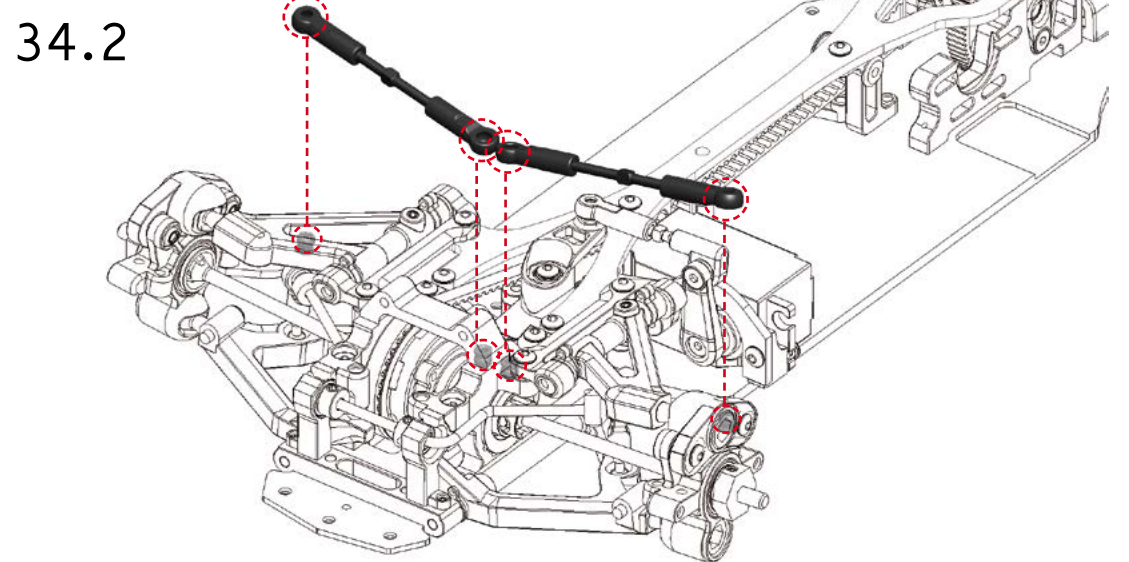

RCM SHOCK ASSEMBLY

STEP
35

Bag
9

35.1

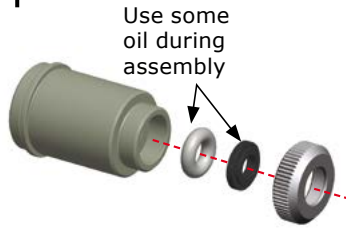

35.2

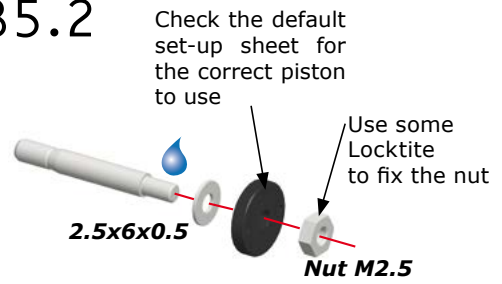

35.3

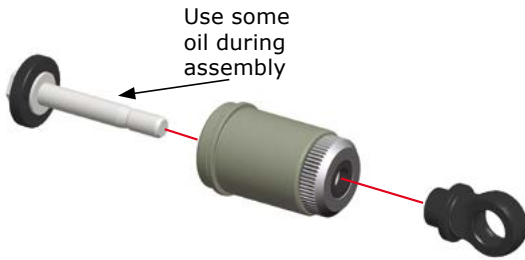

35.4

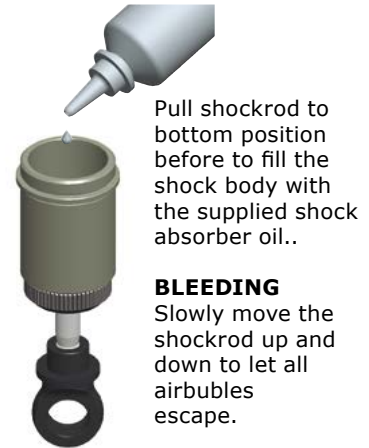

35.5

Close the top of the shock



After assembly ensure you can push the piston all the way in (top of balljoint should hit the shock-bottom). If not, re-open the shock and let some oil bleed out, and repeat the steps.

Allow some 'rebound' on the shockshaft, around 4mm is normal.

35.6

Measure fully extended

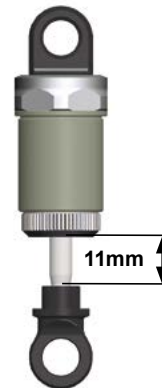

35.7

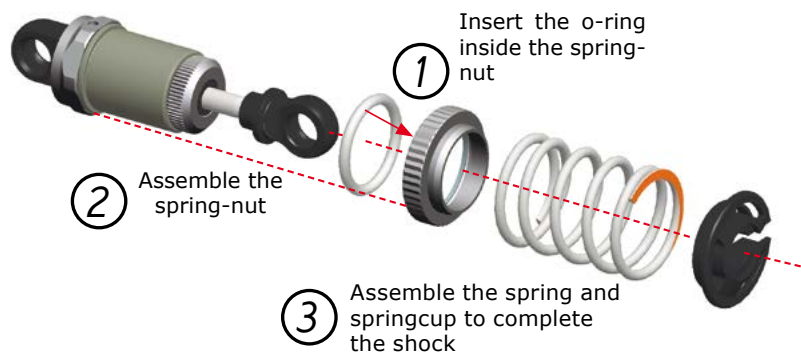

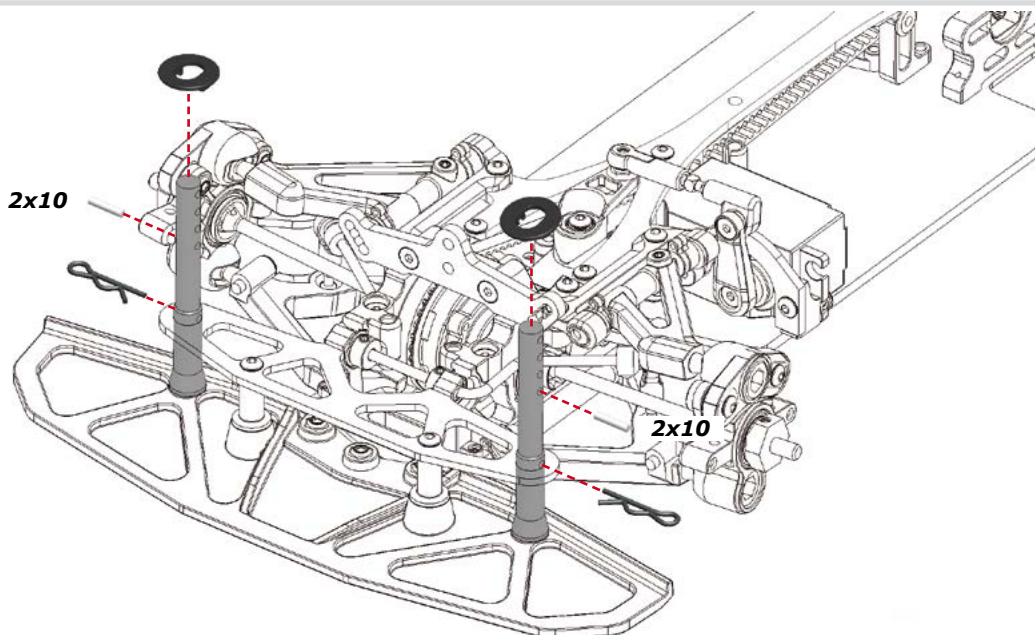
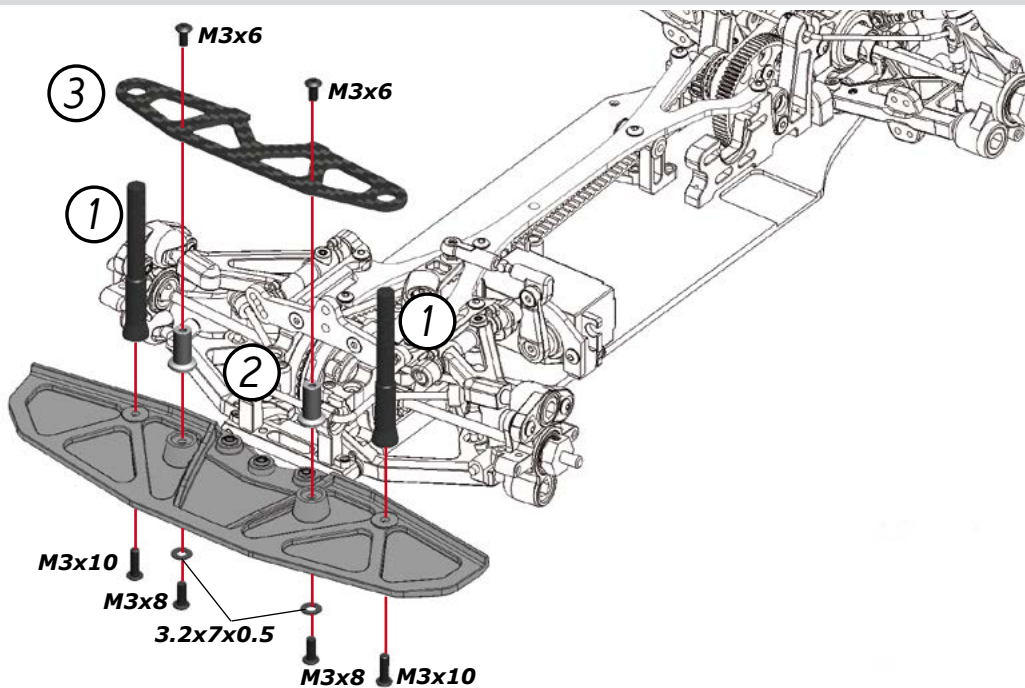
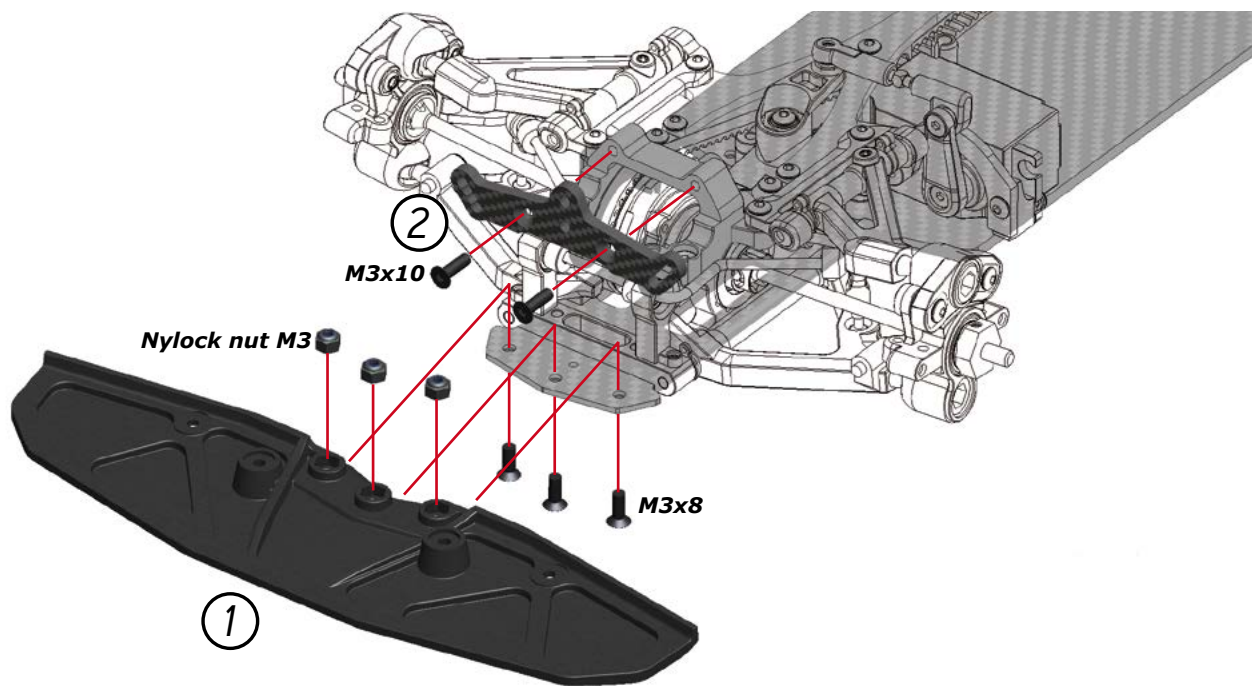

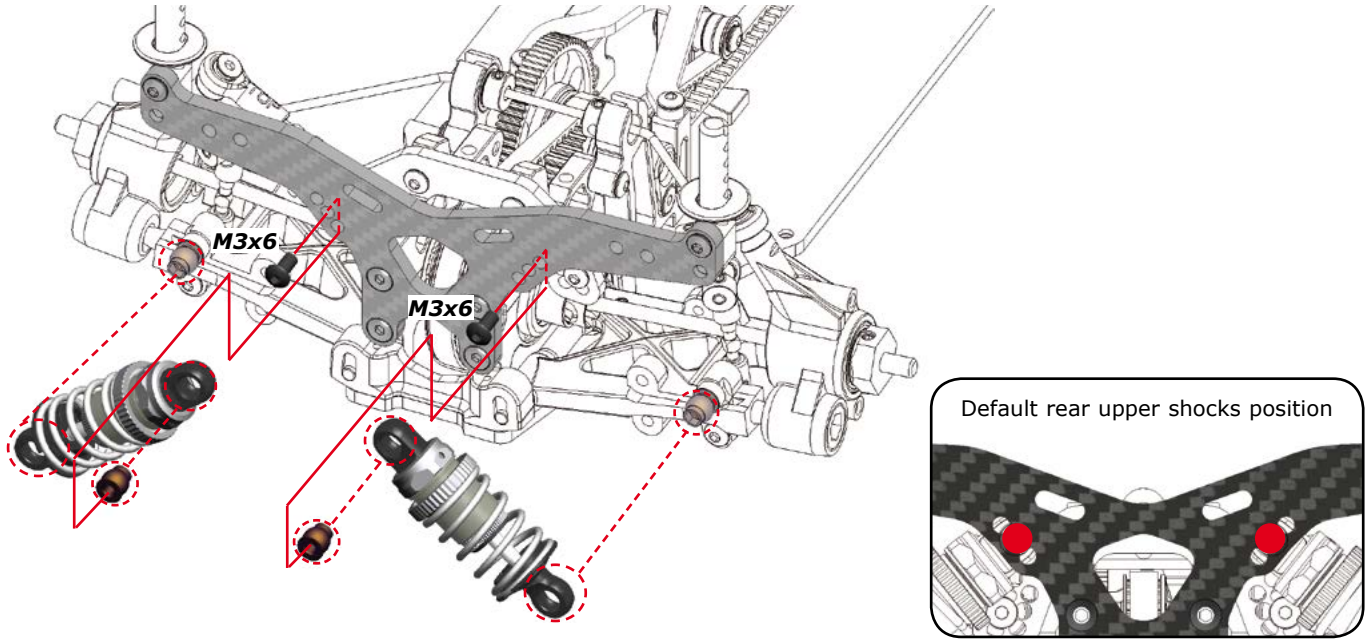
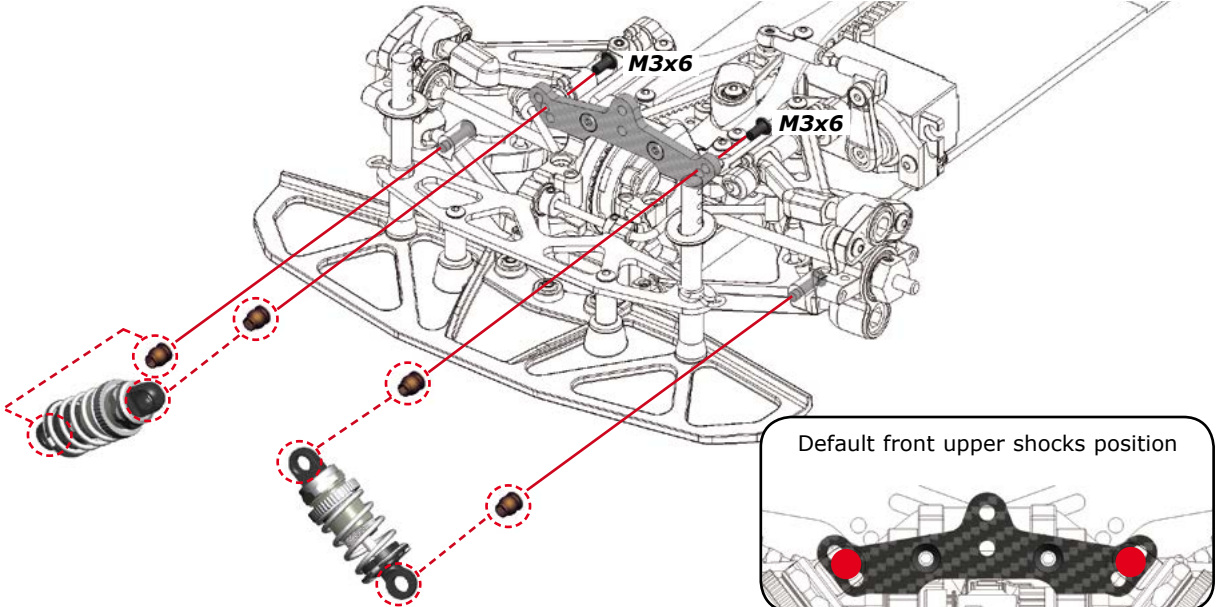

ELECTRONICS ASSEMBLY

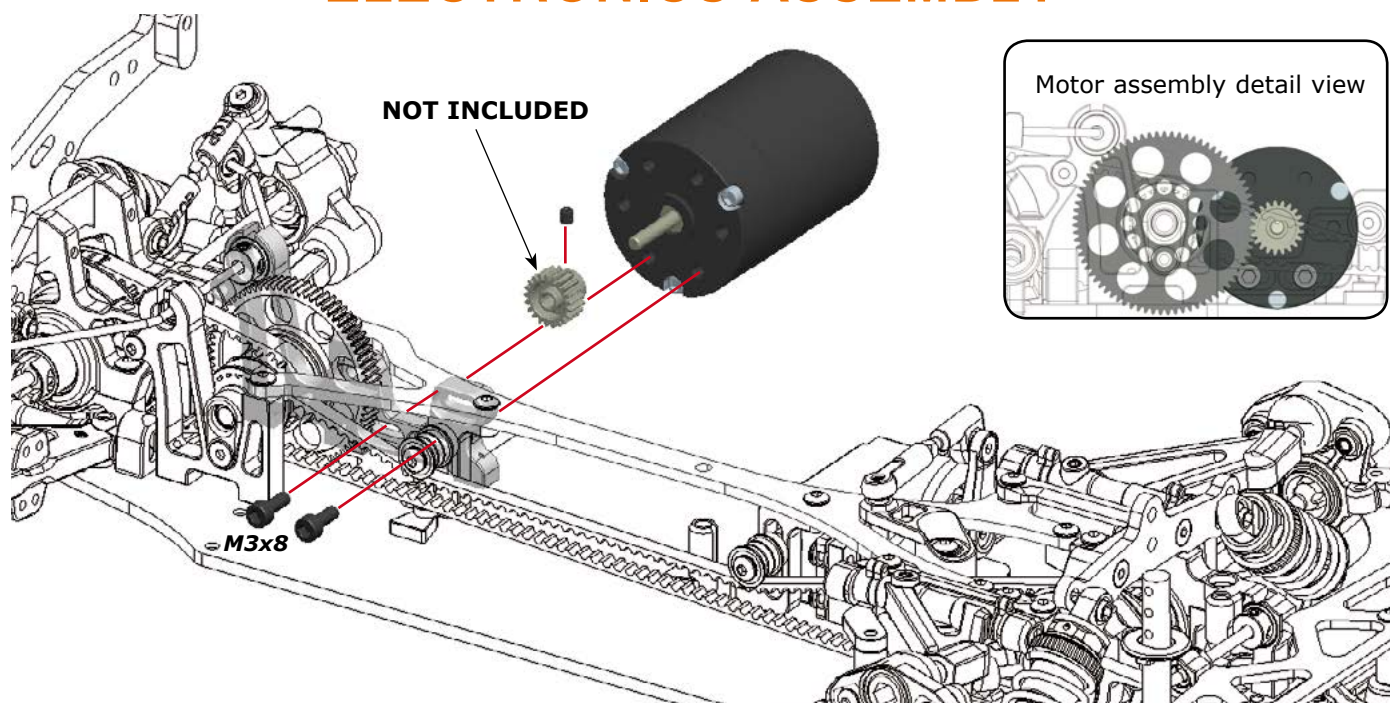

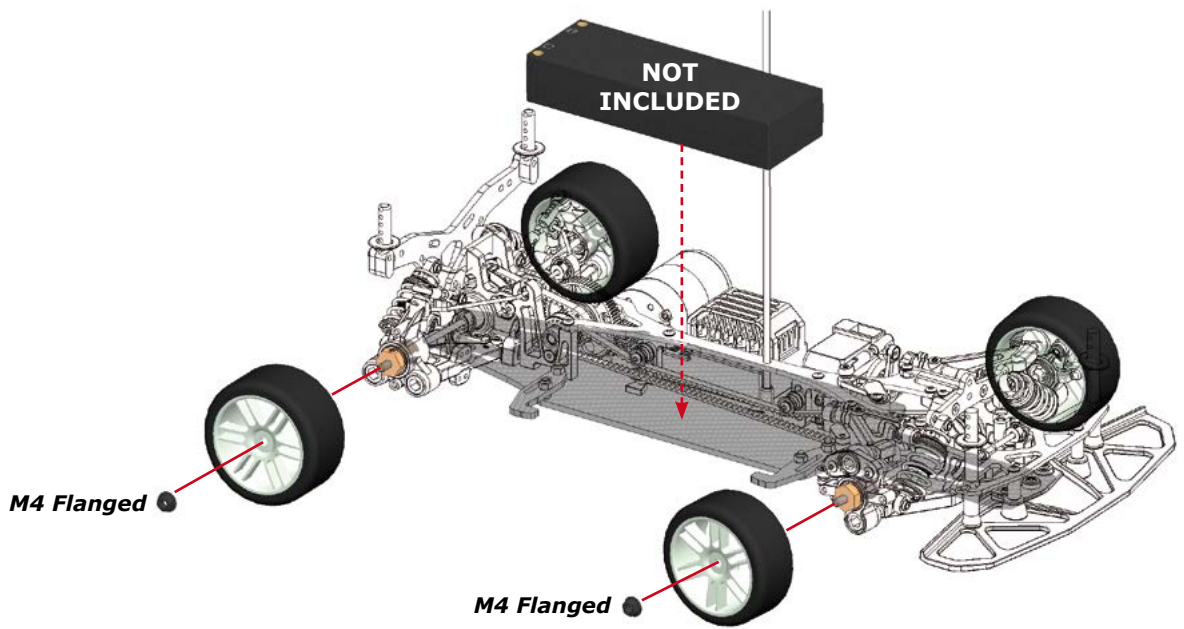
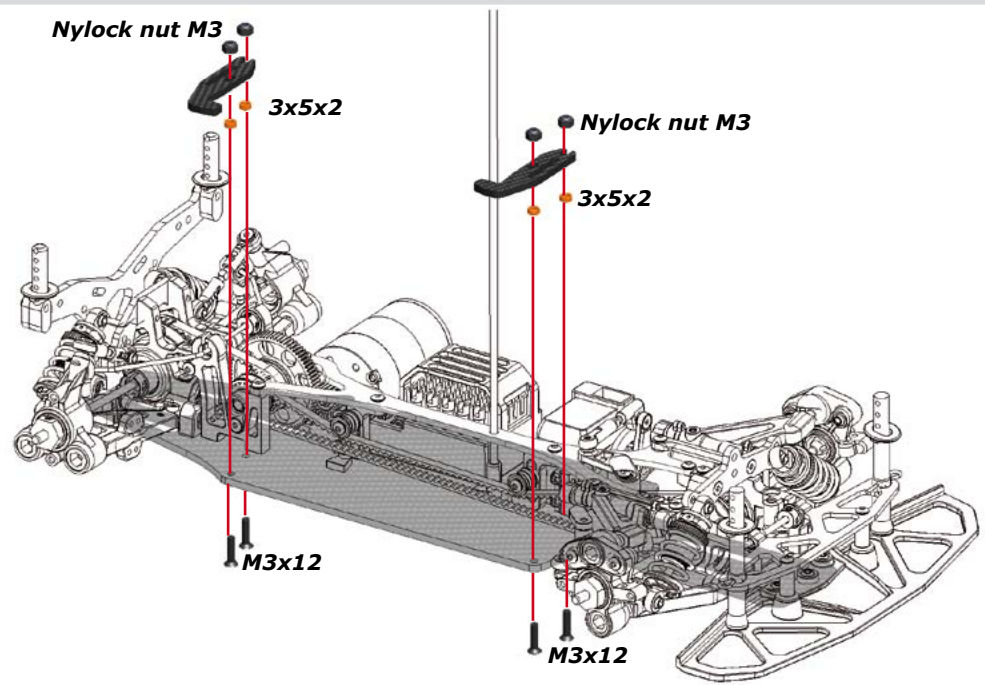
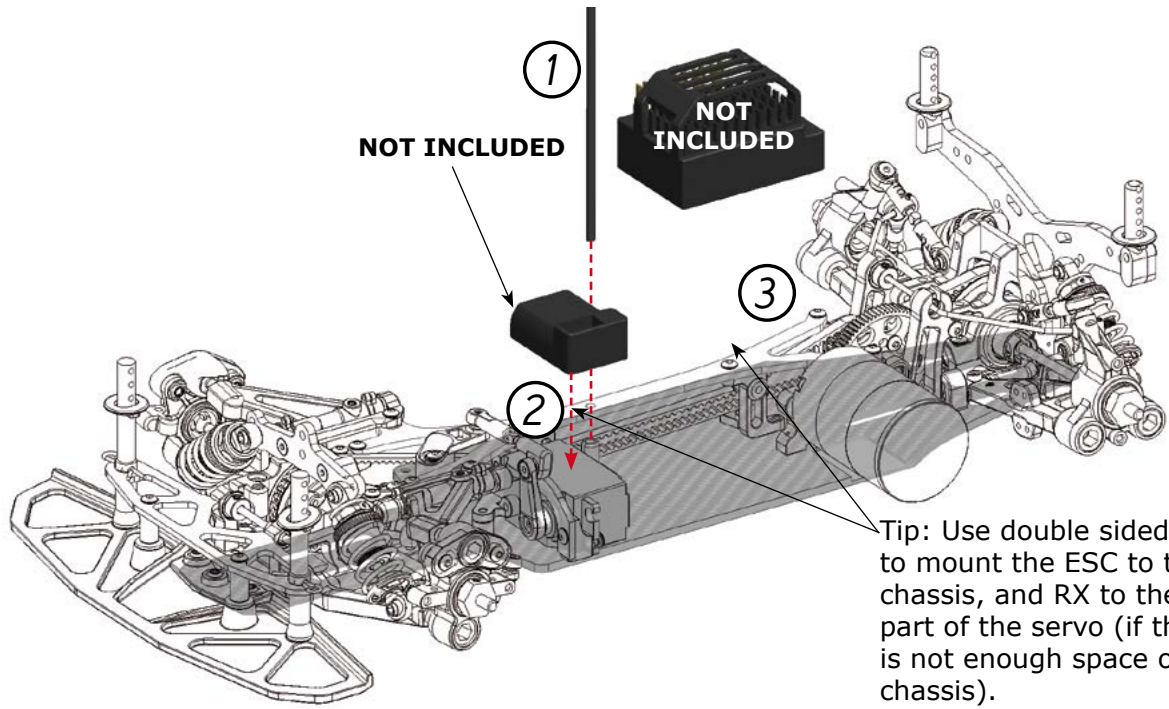

REFERENCE GUIDE

MID SHAFT ASSEMBLY

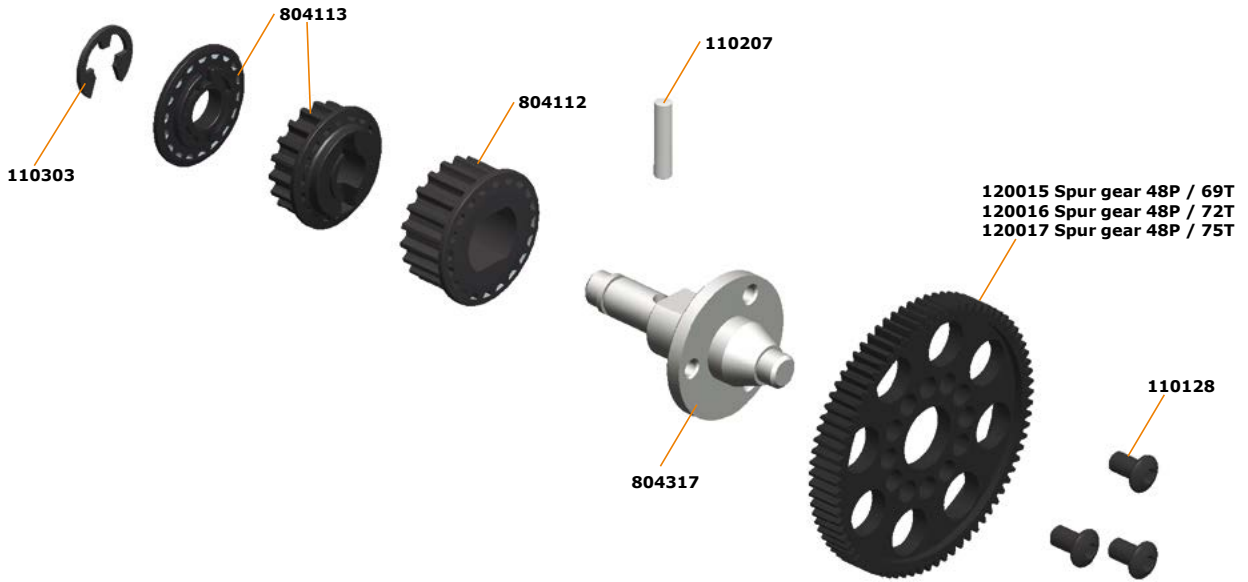

FR/RR DIFF ASSEMBLY

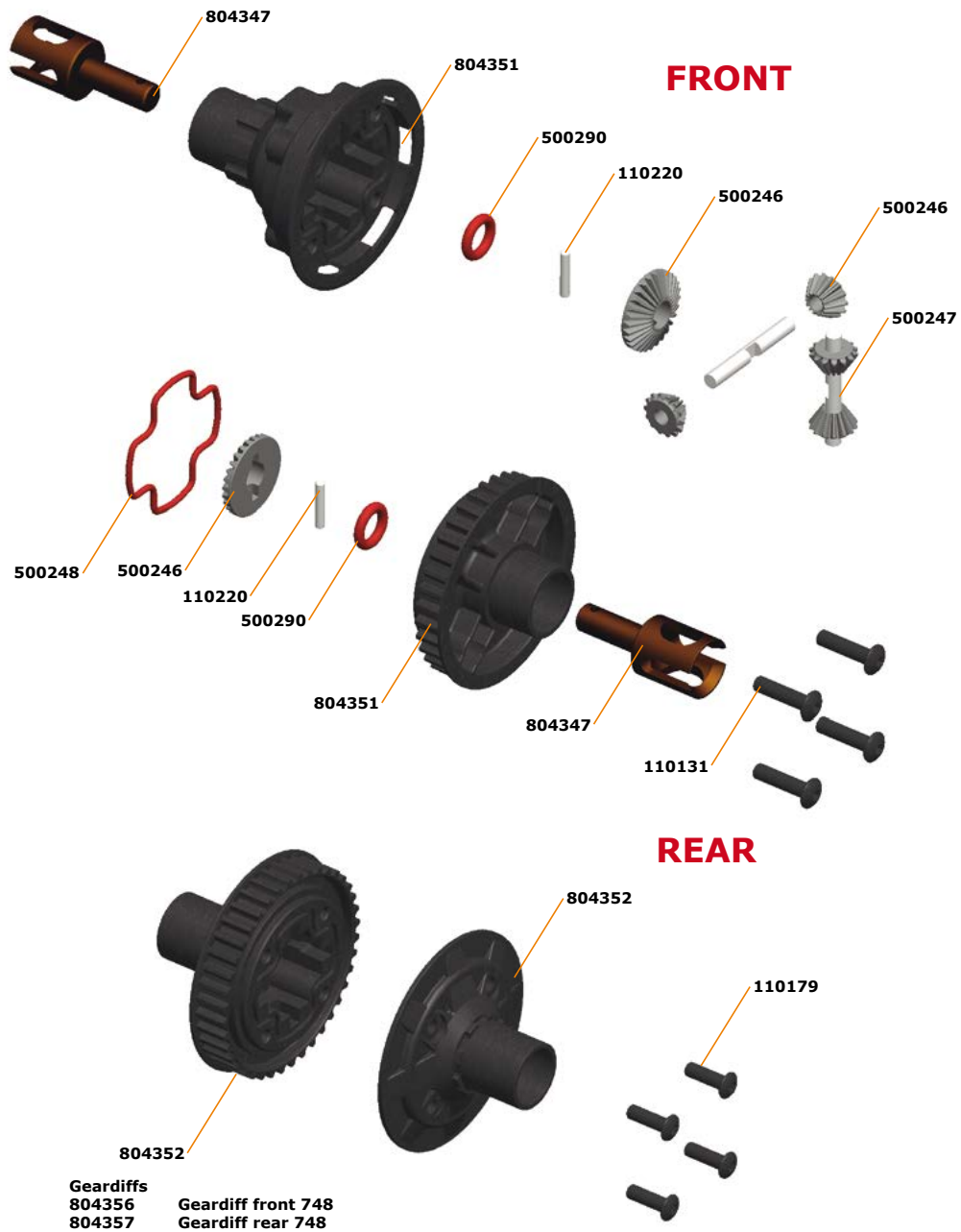

REAR ASSEMBLY

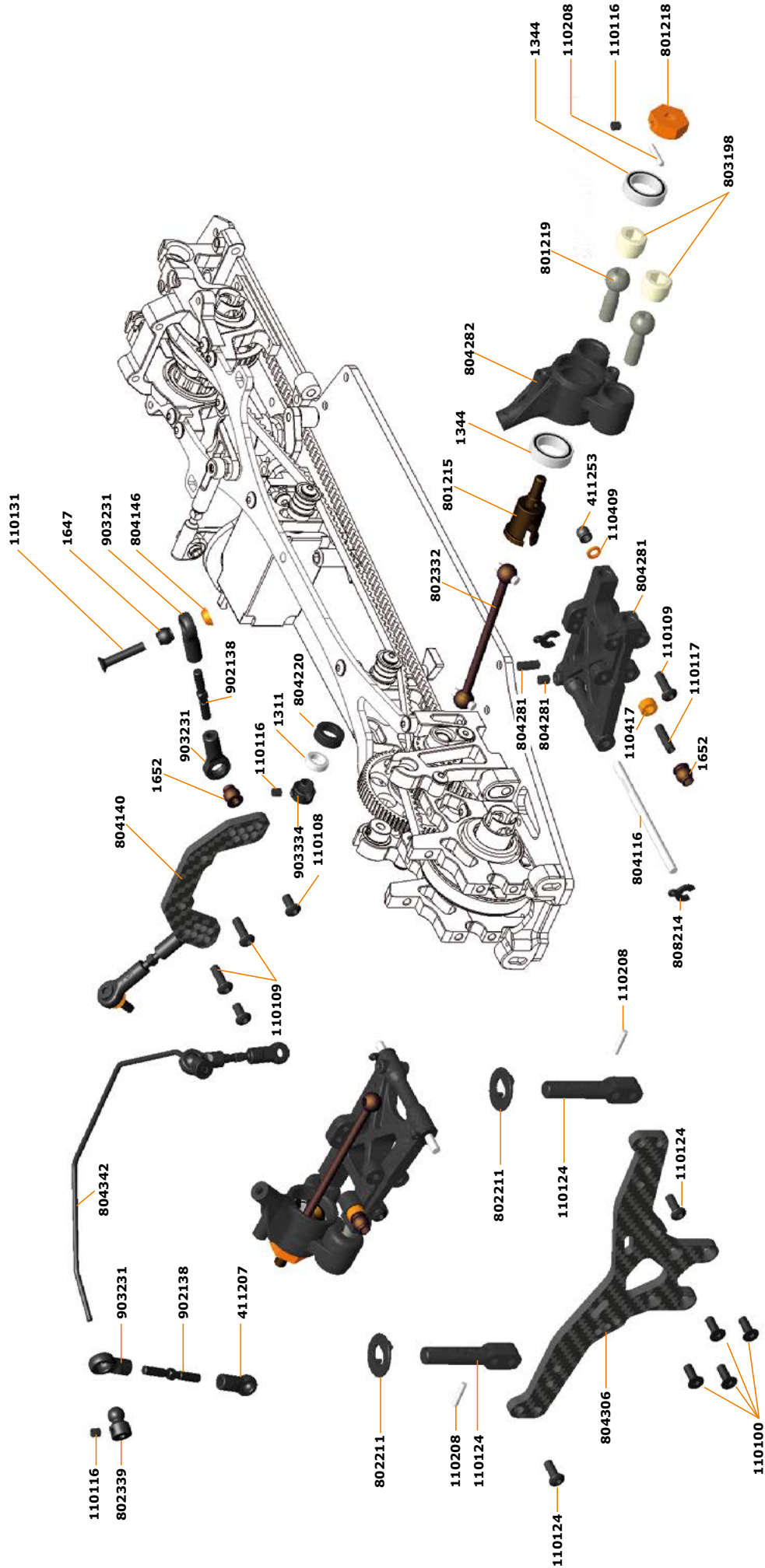

FINAL ASSEMBLY II

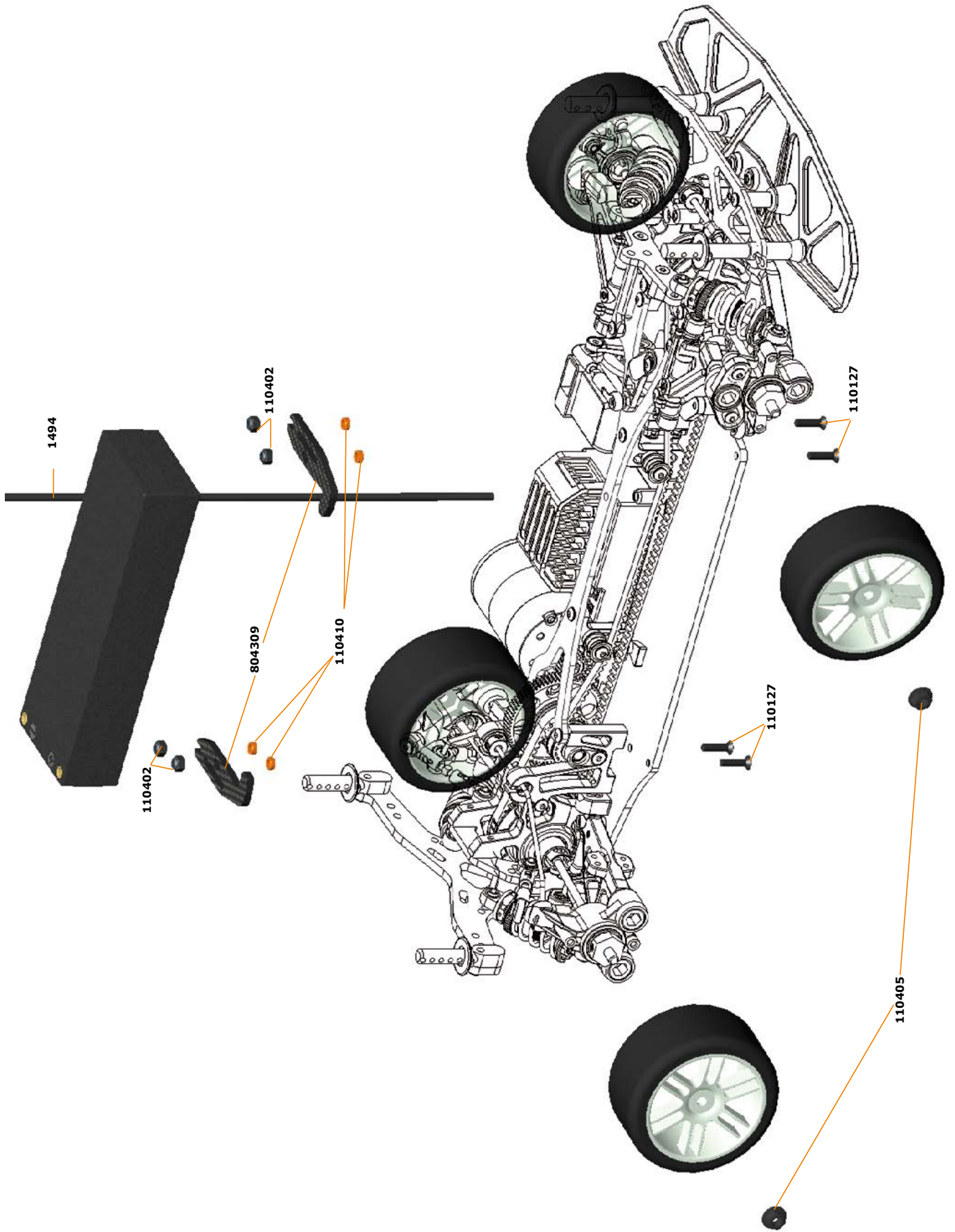

TEAM SERPENT NETWORK

NATRIX 748e SPARES



NATRIX 748e OPTIONALS



SERPENT TOOLS



SERPENT MERCHANDISING



WEBSITE AND BLOG



SOCIAL MEDIA



748e *NATRIX* electric powered



www.serpent.com - info@serpent.com



748e version 1