

INSTRUCTION MANUAL

SR10

1/12 Scale electric powered

PRO

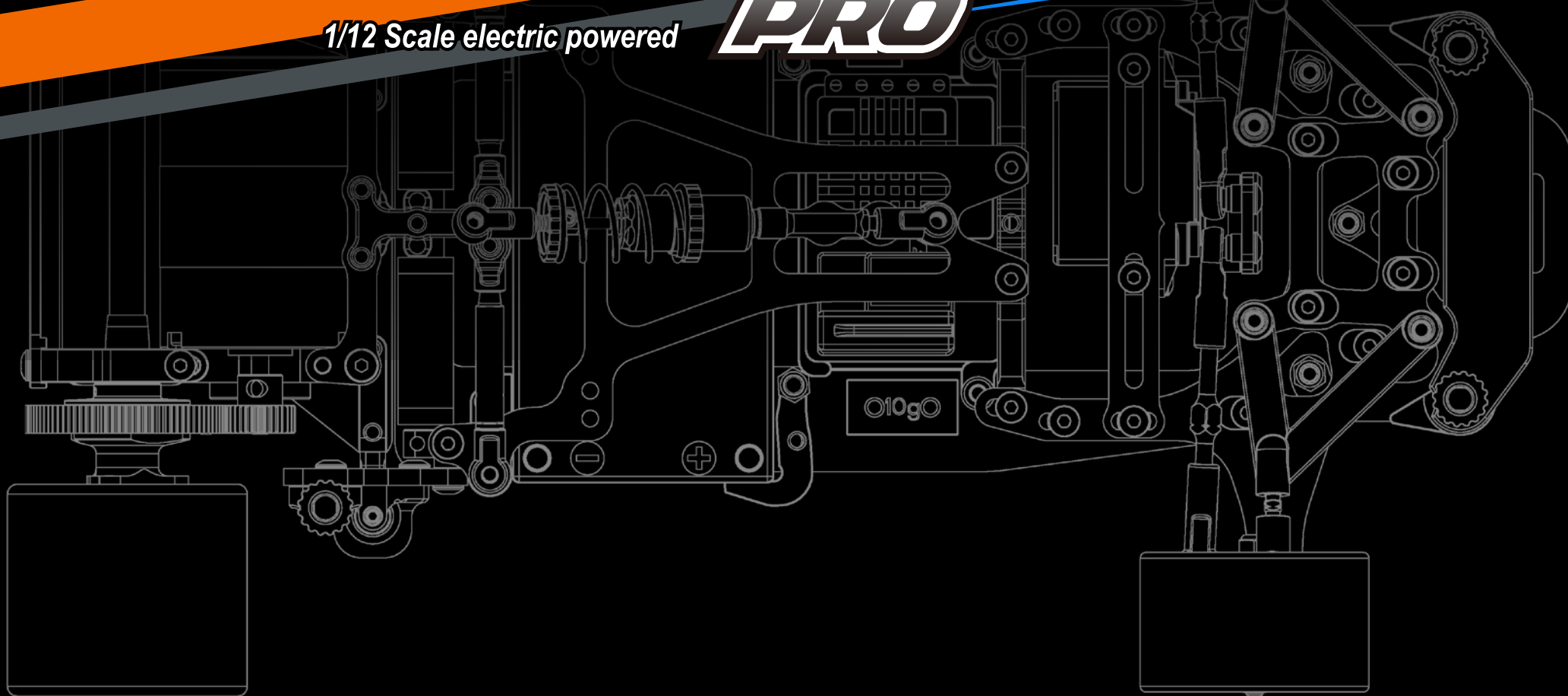

SERPENT

INTRODUCTION

Serpent developed the S120 PRO model car for demanding racers in the highly competitive electric 1/12th scale pan car market, which like all our previous cars, has been designed to win straight from the box.

Featuring a number of very effective features such as a fully adjustable front end, machined aluminium rear pod, side-links combined with ball-link tube-system to control chassis roll and grip, top-mounted shock-absorber, quick and easy tweak adjustment and PRO quality materials throughout, the S120-PRO should see you in the winners circle in no time. In fact everything associated with this car is of the highest quality, from the packaging and supplied manuals, right through to the product and race support.

Enjoy racing !

Team Serpent

INSTRUCTIONS

Serpent's long tradition of excellence extends to the instruction manuals, and this instruction manual is no exception. The easy-to-follow layout is richly illustrated with 3D-rendered full-color images to make your building experience quick and easy. Following the instructions will result in a well-built, high-performance race-car that will soon be able to unleash its full potential at the racetrack.

INSTRUCTIONS , HOW TO USE

The kit includes bags, with bag numbers, which refer to the same step in the manual. Open only the indicated bag(s) per step and finish that part of the assembly. Remaining parts will be needed later on in the assembly process.

SETUP

In certain assembly steps you need to make basic adjustments, which will give you a good initial setup for your Serpent S120-PRO. Fine-tuning the initial setup is an essential part of building a high-performance racecar like your S120-PRO.

EXPLODED VIEWS AND PARTS LIST

The exploded views and parts lists for the Serpent S120-PRO are presented in the Reference Guide section in the back of this manual. The exploded views show all the parts of a particular assembly step along with the Serpent part number. The parts lists indicate the part number and name of each part for easy reference when ordering.

CUSTOMER SERVICE

Serpent has made a strong effort to make this manual as complete and clear as possible. Additional info may be published in our website: www.serpent.com or you may ask your dealer or the Serpent distributor for advice, or email Serpent direct: info@serpent.com

The Serpent Facebook, Twitter and Youtube pages give additional means of support and communications.

SAFETY

Read and take note of the 'Read this First section' before proceeding to assemble the car-kit. This car-kit is intended for persons aged 16 or older.

Read this first!

- This is a highly technical hobby product, intended to be used in a safe racing environment. This car is capable of speeds in excess of 80 km/h or 50mph. Please follow these guidelines when building and operating this model.
 - Parental guidance is required when the builder/user of this car is under 16.
 - Follow the building instructions. If in doubt, contact your dealer or importer.
 - Be sure to use the proper tools when assembling the car. Always exercise caution when using electric tools, knives and other sharp objects.
 - Be careful when using liquids like lubrication oil, fuel or glue. Do not swallow.
 - Follow the manufacturer's instruction in case you experience irritation after using the product.
 - Be careful when operating the car. Stay away from any rotating parts such as wheels, gears and transmission. Stay away from motor, engine and exhaust pipe system or speedo during and immediately after use, as these parts may be very hot. We advise to use protective hand gloves.
 - Only operate this car in a safe environment, like a special racing track or a closed parking lot. Avoid using this car on public roads, crowded places or near infants.
 - Before operating this car, always check the mechanical status of the car. Also check that the transmitter and receiver frequencies correspond and are not used by any other racer at the same time. Check that the batteries of the transmitter and receiver are fully charged.
 - After use, always check all the mechanics of the car. We advise to clean the car immediately after use, and inspect the parts for wear or fractures.
- Replace when necessary. Do not use water, methanol, thinner or other solvents to clean the car.
- Empty the fuel tank (depending on model) if needed and disconnect the receiver battery.
 - Store the car in a dry and heated place to avoid corrosion of metal parts.
 - Avoid using this car in wet conditions as the water will cause corrosion on the metal parts and bearings and these parts will cease to function properly. If driven in the wet, ensure that all the electric equipment is waterproofed and after use, that all moving parts are dried immediately.

LINES DESCRIPTION

Each step contains a variety of numbers, lines, and symbols. The numbers represent the order in which the parts should be assembled. The lines are described below.



Step number; the order in which you should assemble the indicated parts



Length after assembly



Assembly path of one item into another



Group of items (within lines) should be assembled first

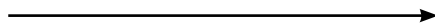

Direction the item should be moved



Glue one item to another



Connect one item to another



Gap between two items



Press/Insert one item into another

ICONS DESCRIPTION

Each step contains a variety of symbols described below.



Carefull, read and check very well.



Apply a small amount of cyano glue. Use wear protection for eyes and hands.



Detail view to explain assembly or order of parts better.



Default set-up: This symbol indicates the default setup.



Grease: apply a small amount of grease to the parts shown.



Silicone grease: apply a small amount of grease to the parts shown.



Thread lock: apply a small amount on the parts shown. Before to apply the threadlock, make sure to degrease the parts very well, as otherwise the threadlock will not work.



Silicone oil: use the indicated silicone oil for the shocks and differentials.



Oil: apply a small amount of oil to the parts shown.



Left and right parts should be assembled in the same way.



Parts or items not included in the kit.



Optional part, not standard in the kit.

STEP 1

BAG 1

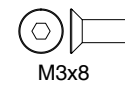
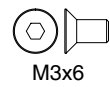
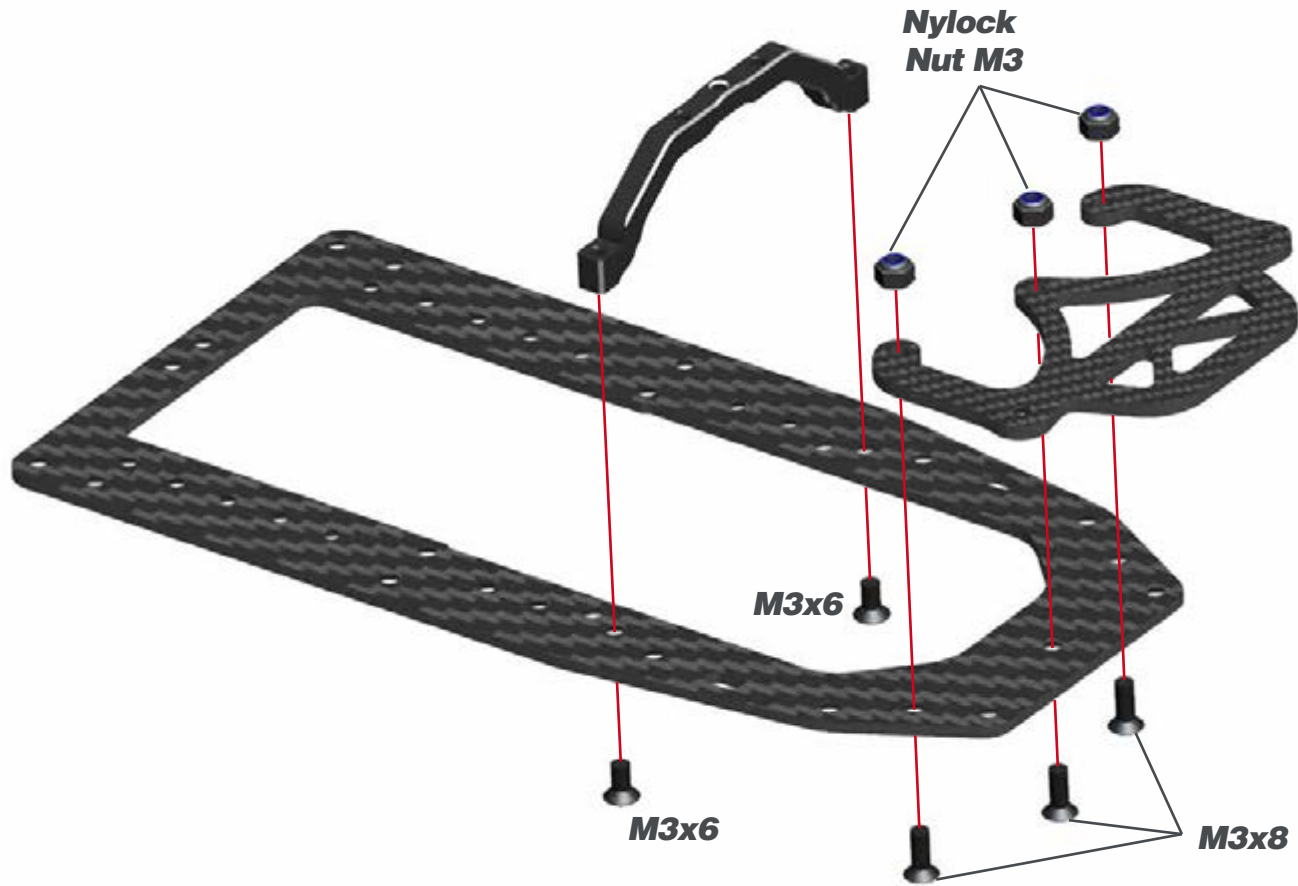

STEP 2

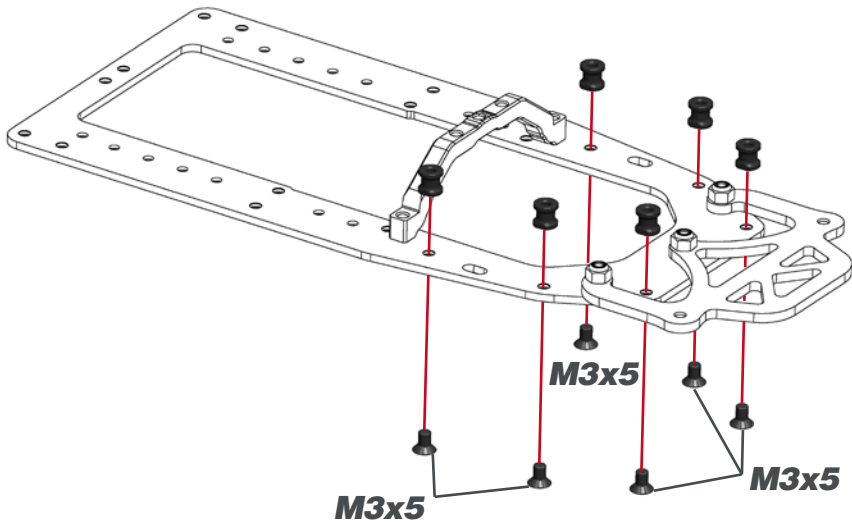

STEP 3

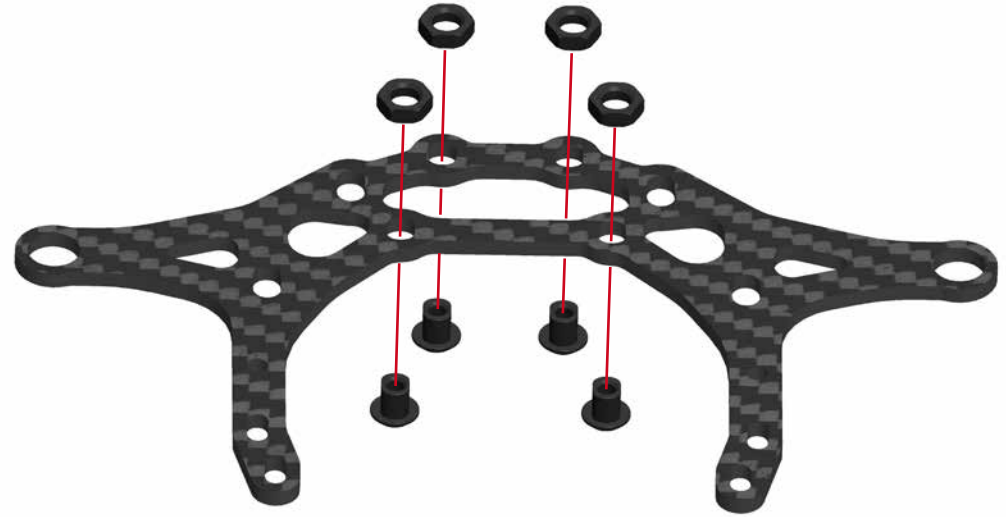

STEP 4

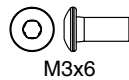
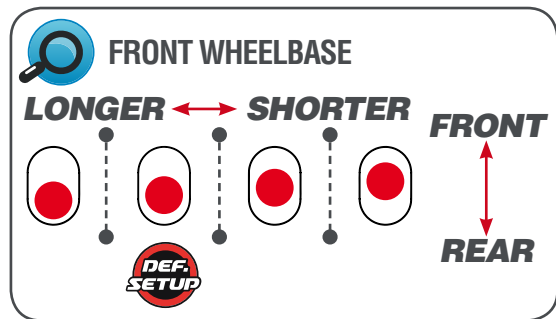
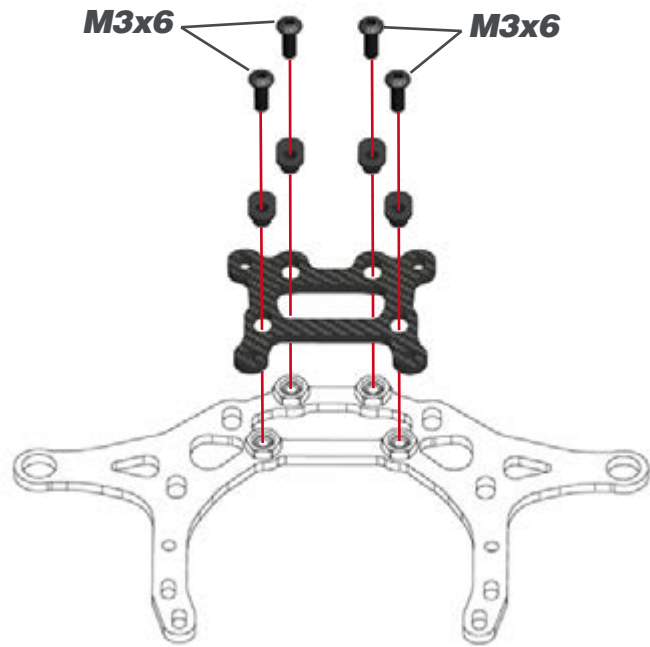

STEP 5

BAG 2

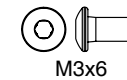
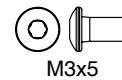
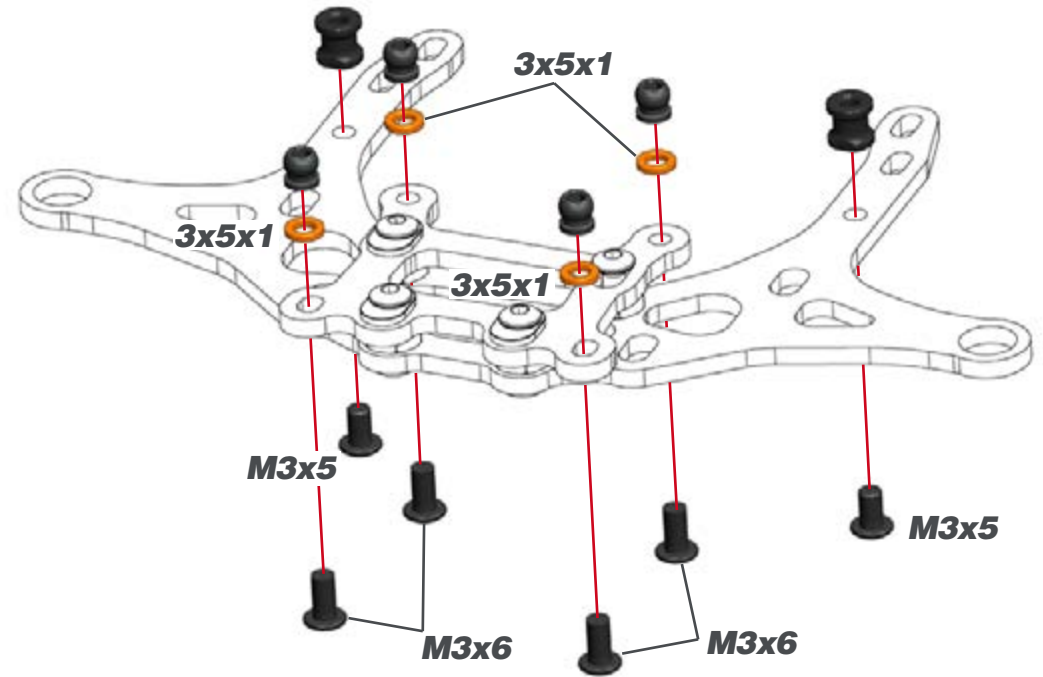

STEP 6

6.1

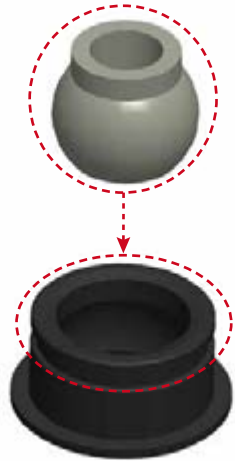

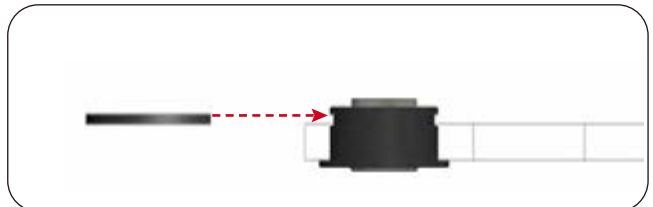
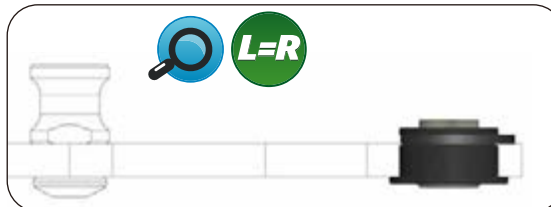
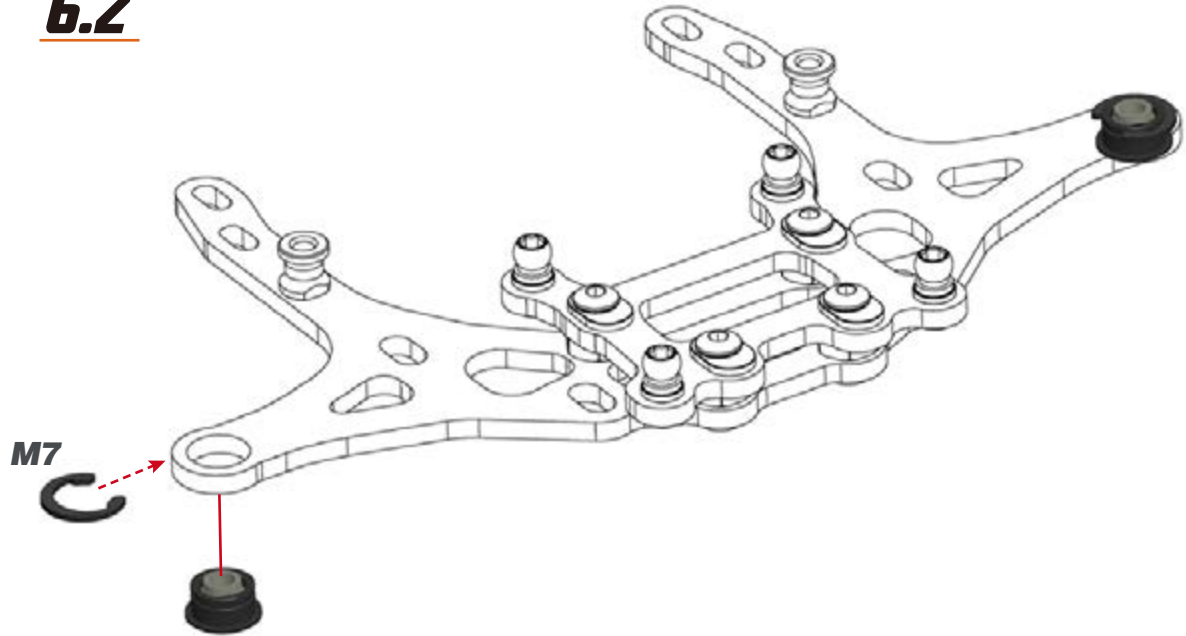

6.2

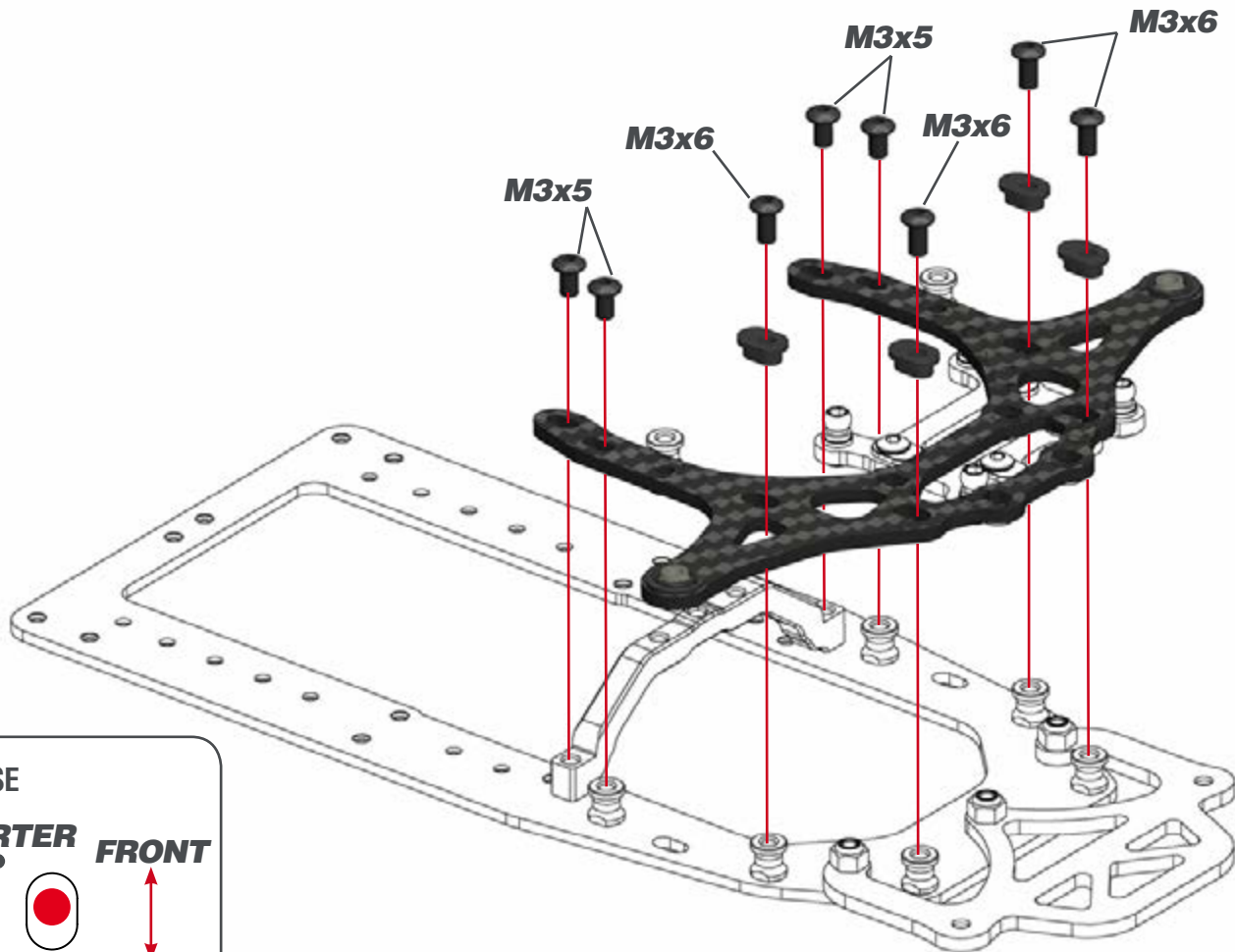

M7

STEP 7



 FRONT WHEELBASE

LONGER ← → SHORTER

FRONT



REAR

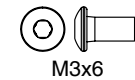
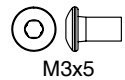



STEP 8



 **L=R**  **FRONT CAMBER**

4 mm



STEP 9

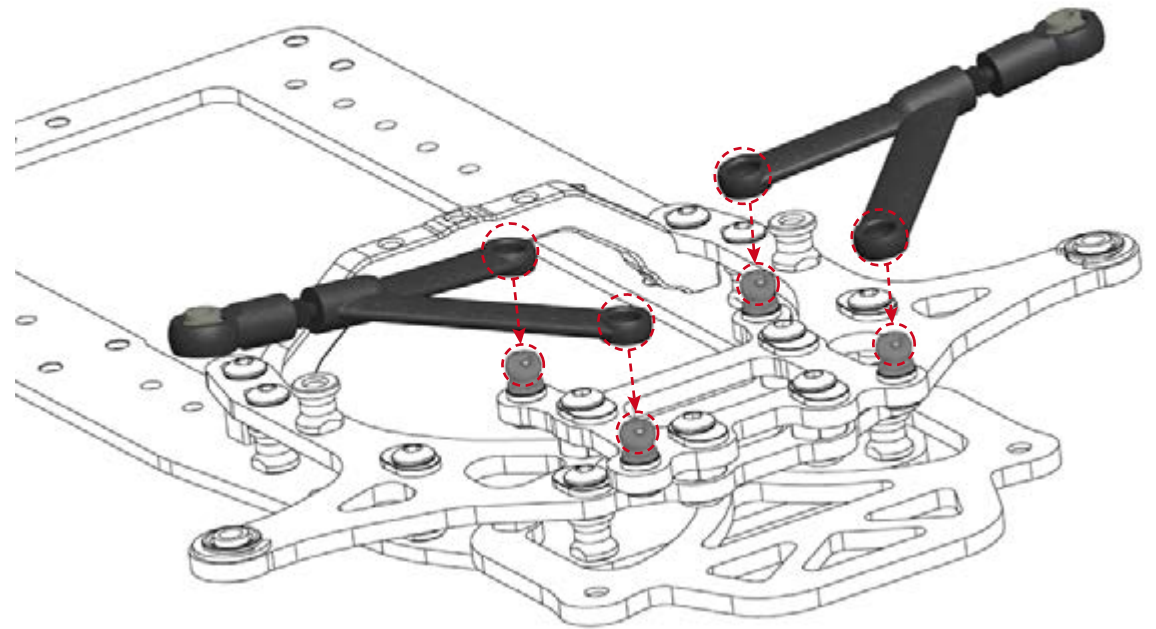

STEP 10

L=R

Right steering block assembly

3x5x1

Nylock Nut M3

M3x6

ACKERMANN POSITION

DEF. SETUP

KING PIN INSERTS CHART

King pin angle adjustable from 0 to 4 degrees.

0°	1°	2°	3°	4°
DEF. SETUP				

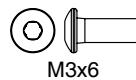

STEP 11

R2-3

3x5x2

3x5x1

R2-3



STEP 12 BAG 3

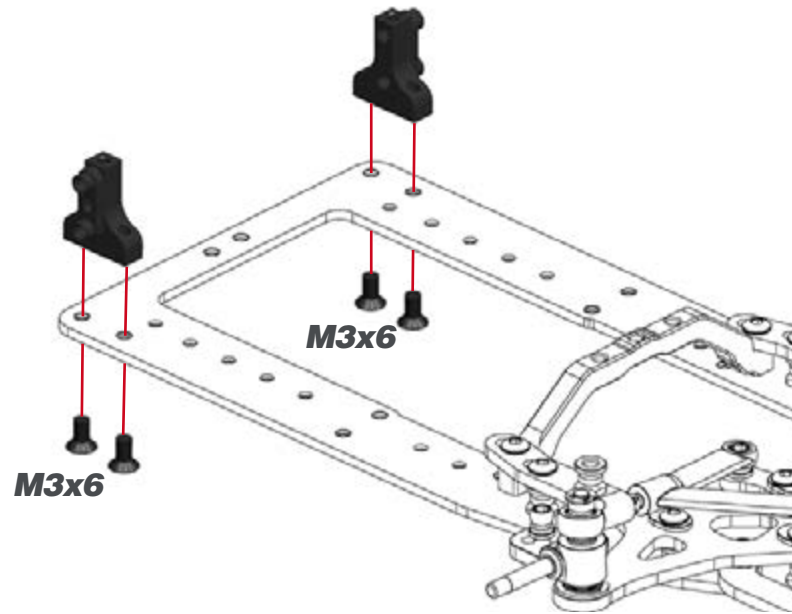

STEP 13

13.1

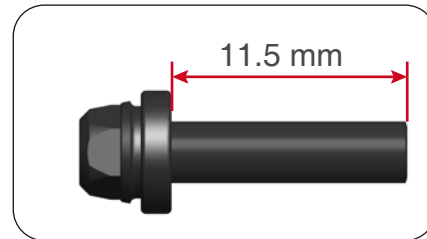
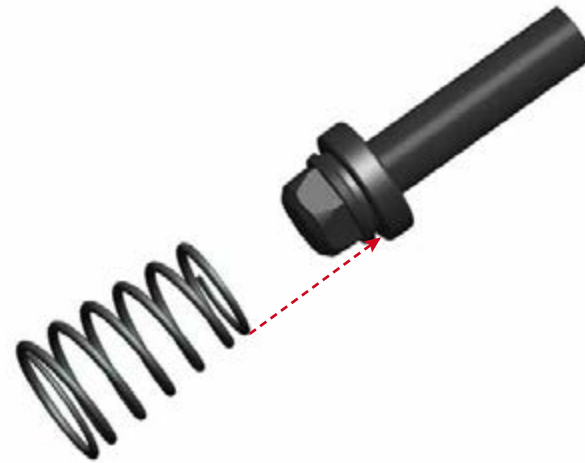

13.2

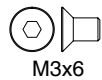
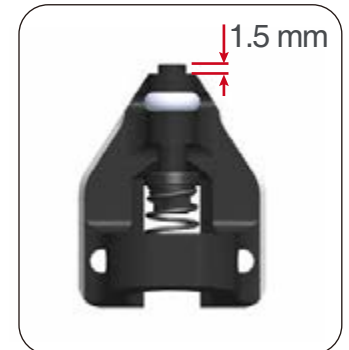

M3x6



M3x14

STEP 14

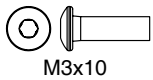
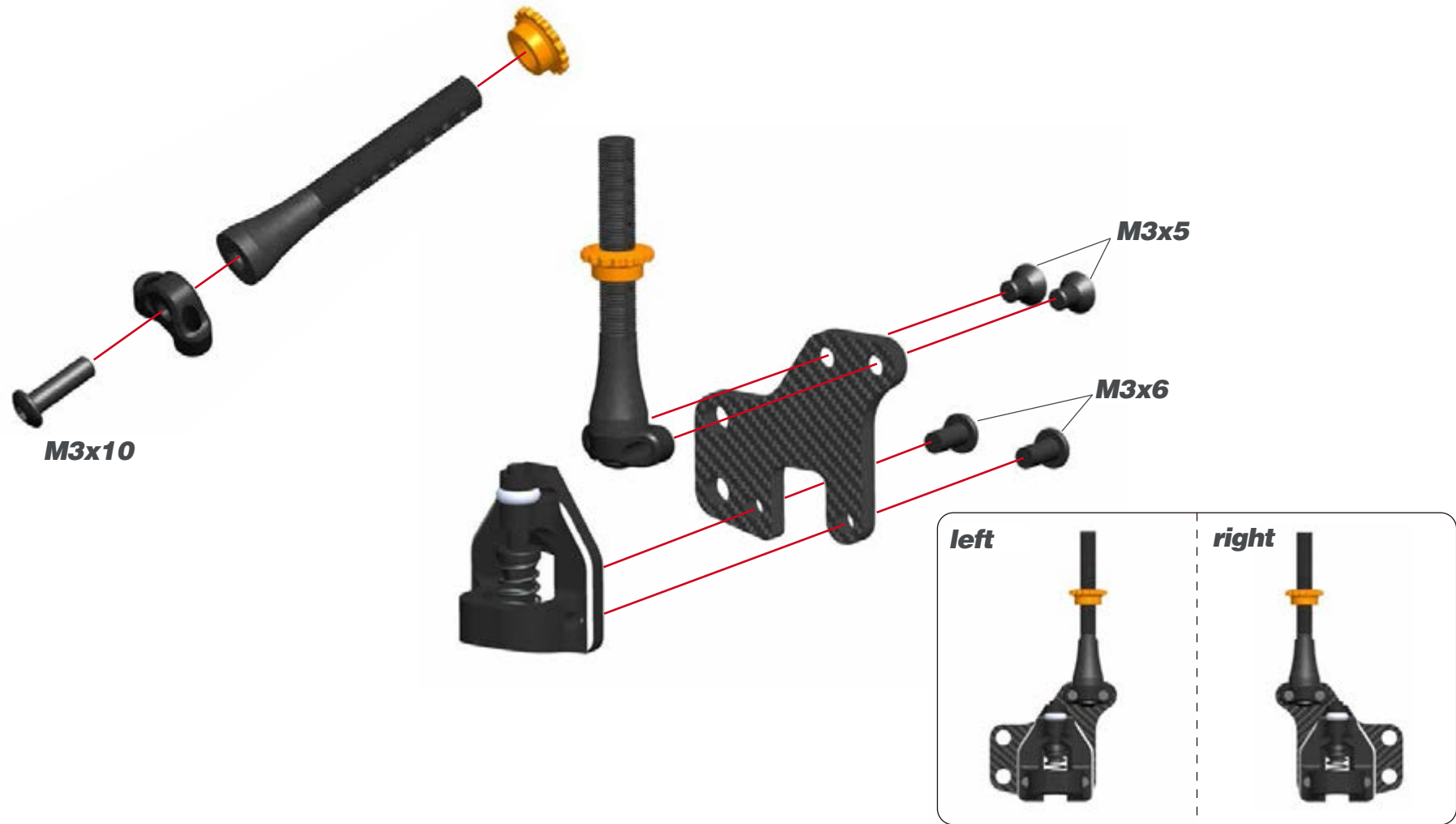

STEP 15

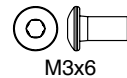
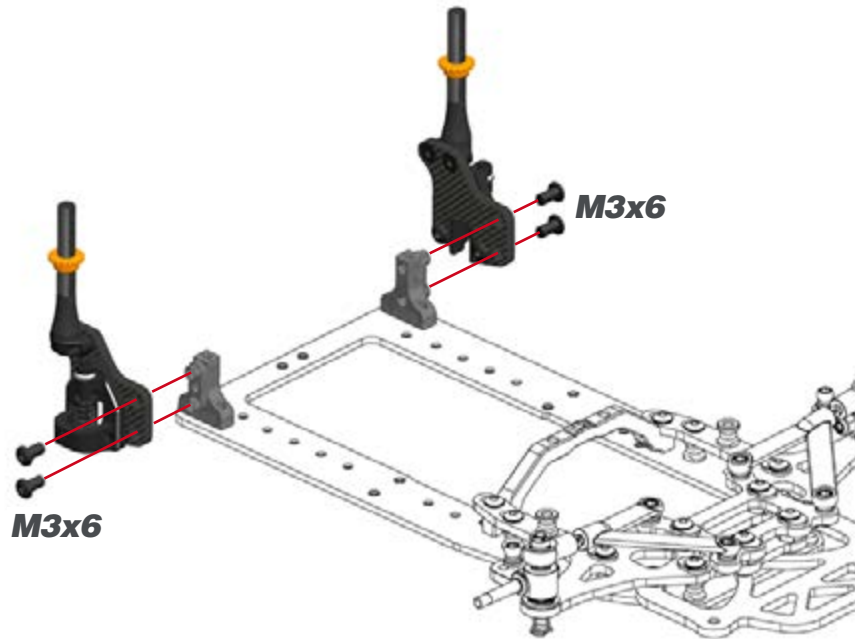

STEP 16

16.1

 To exchange the sidesprings it is needed to remove before the bearing holder.



16.2

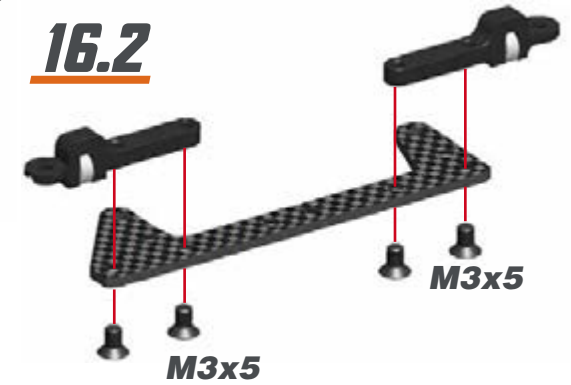

16.3

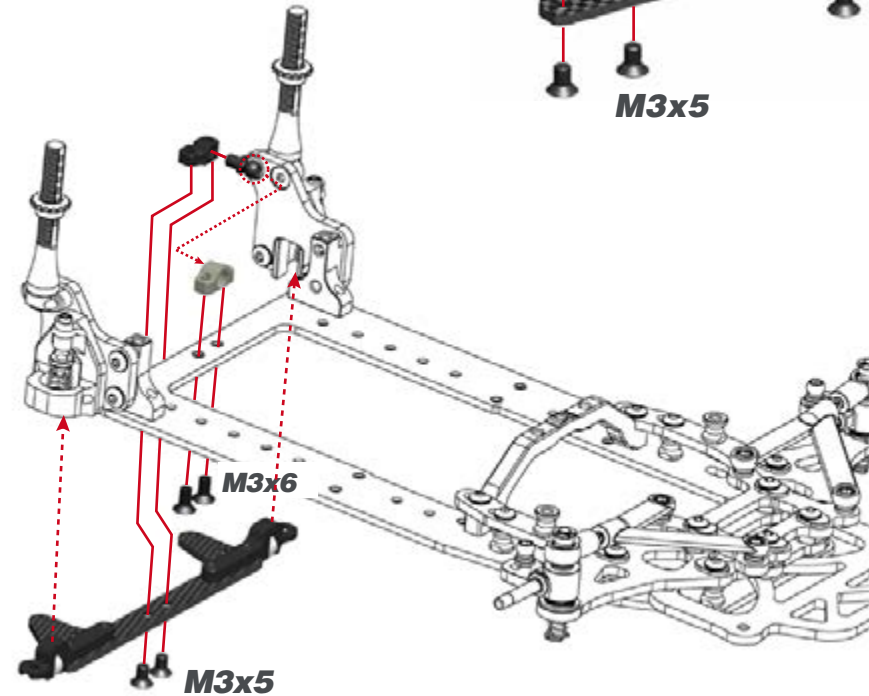

STEP 17 BAG 4

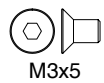
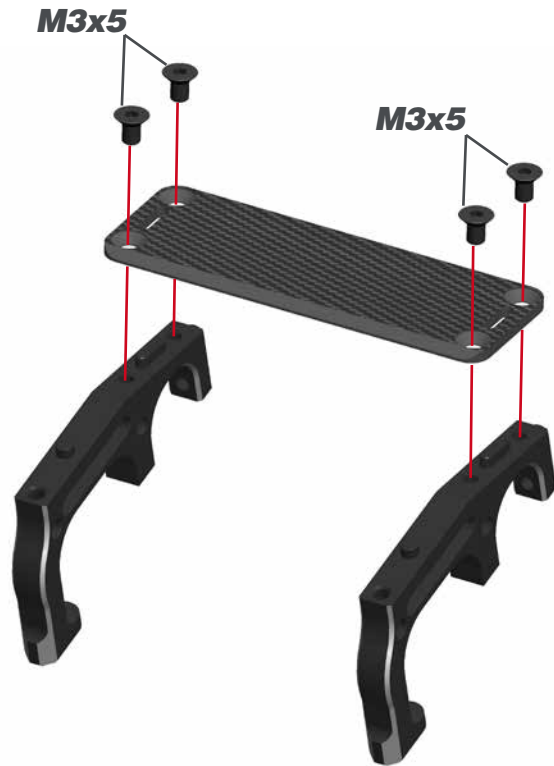

STEP 18

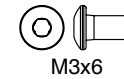
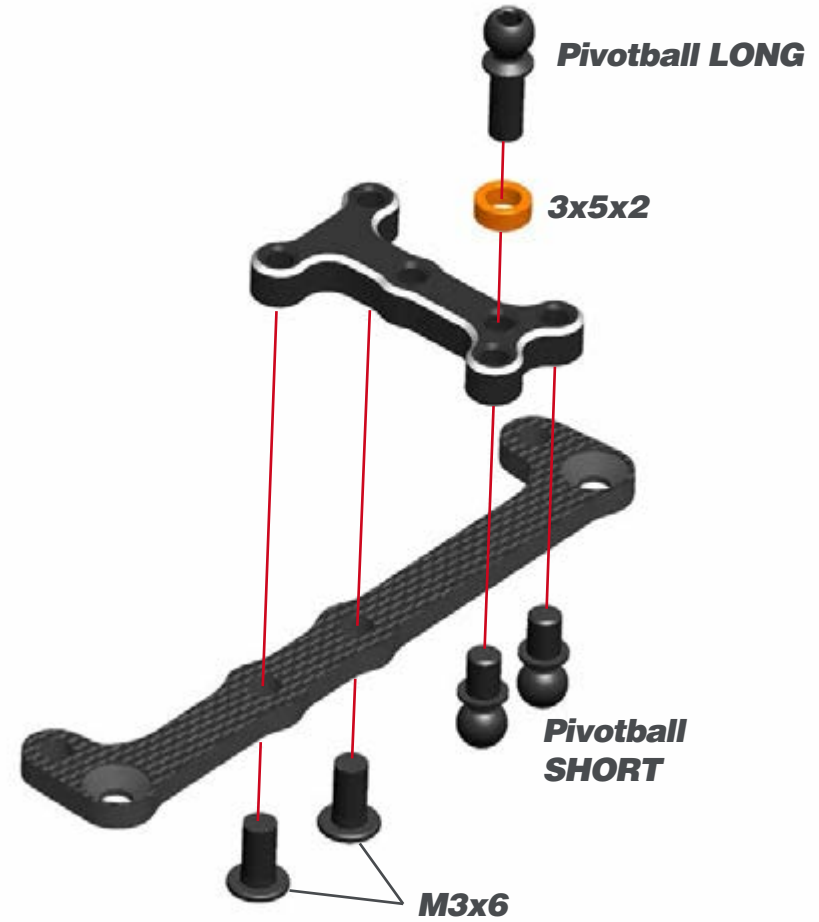

STEP 19

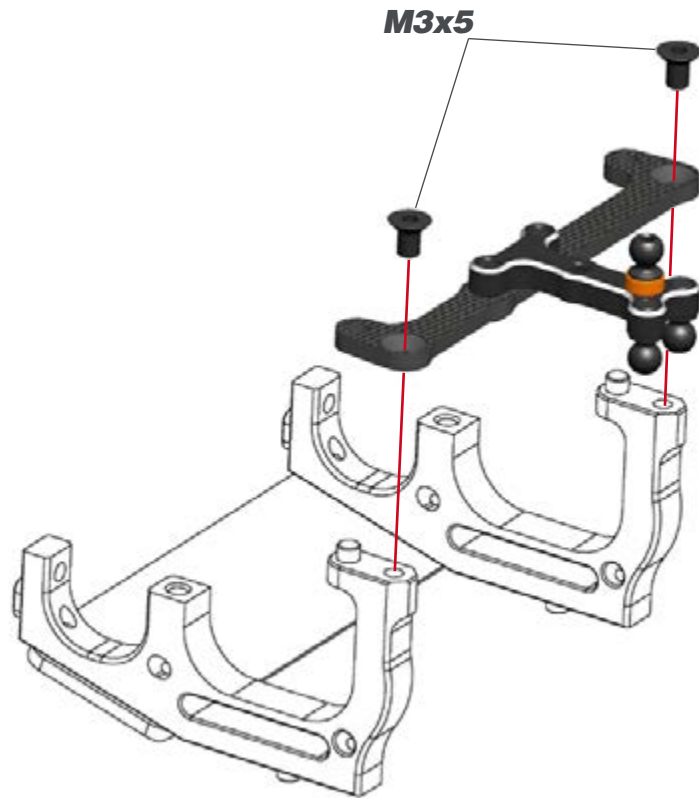

STEP 20

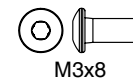
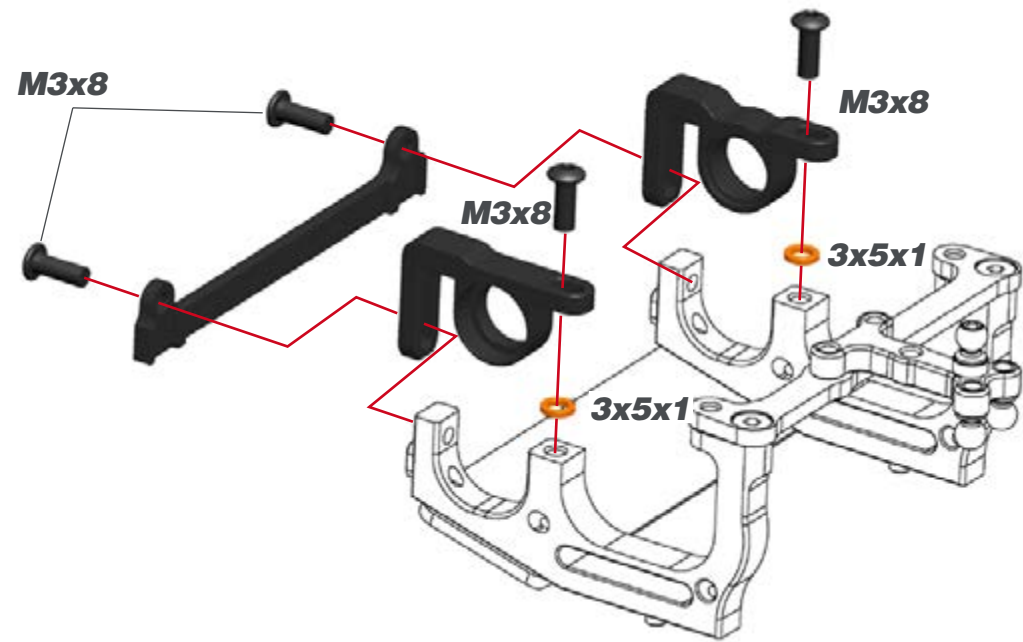

STEP 21

BAG 5

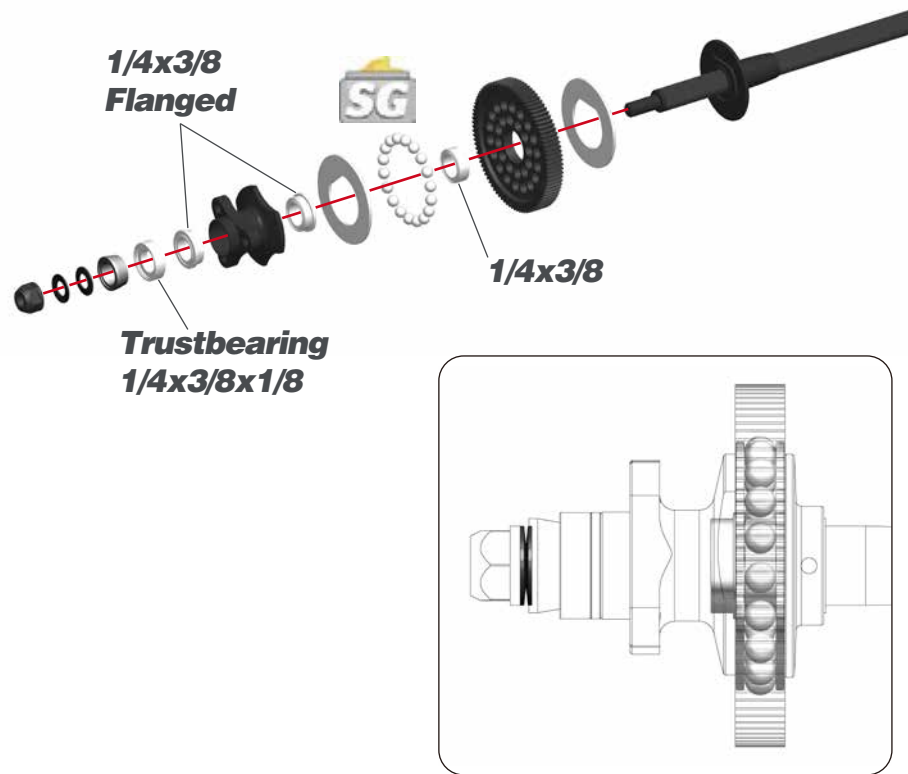

STEP 22

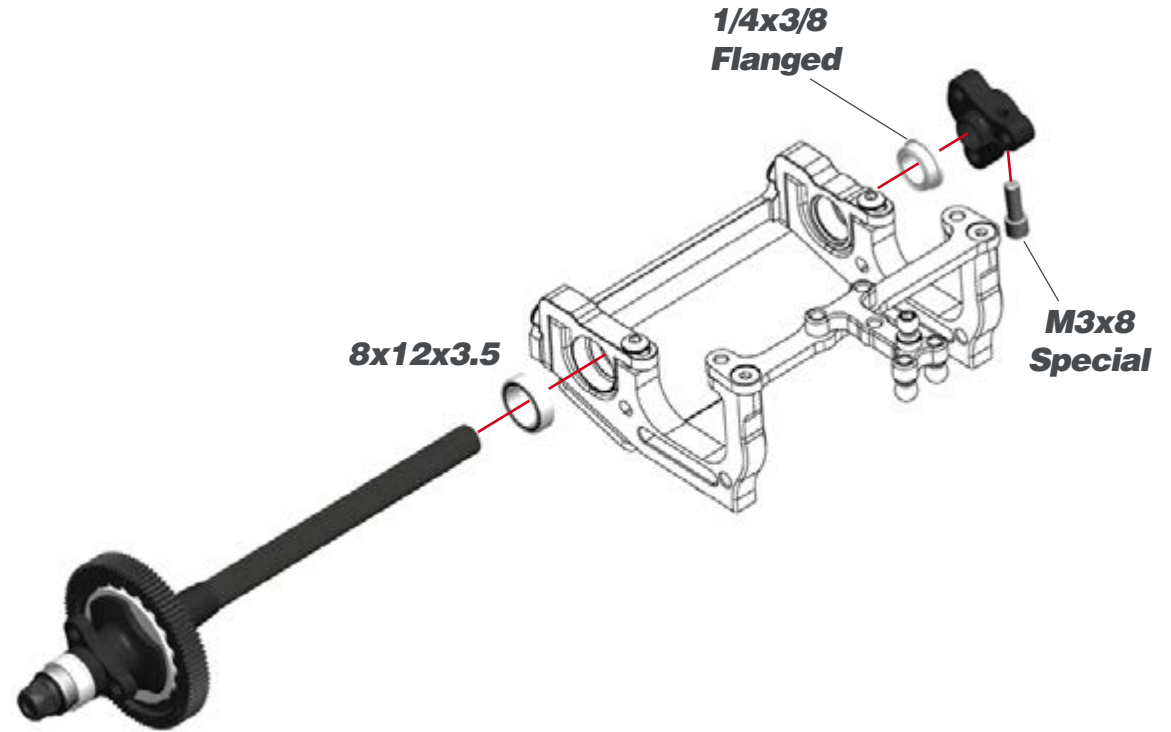

STEP 23

STEP 24

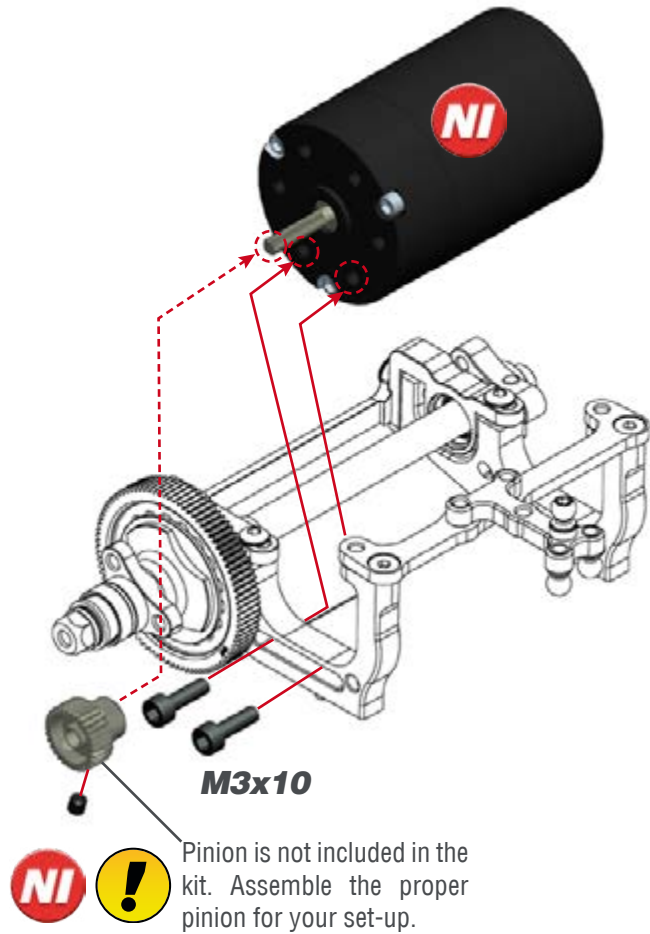

M3x10

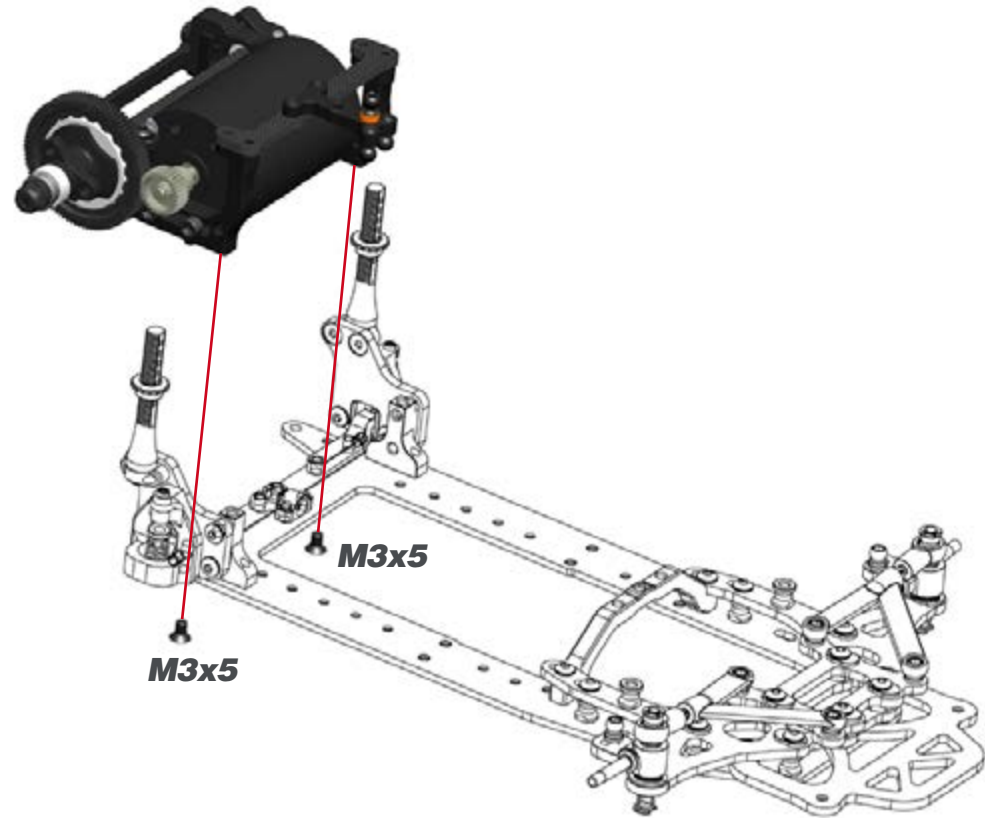

M3x5

STEP 25 BAG 6

25.1

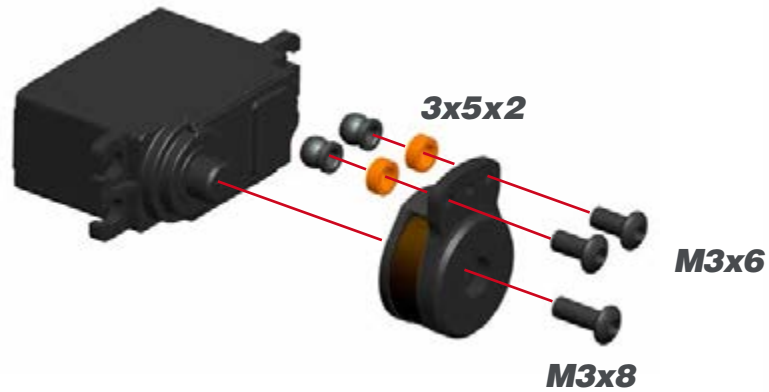

25.2

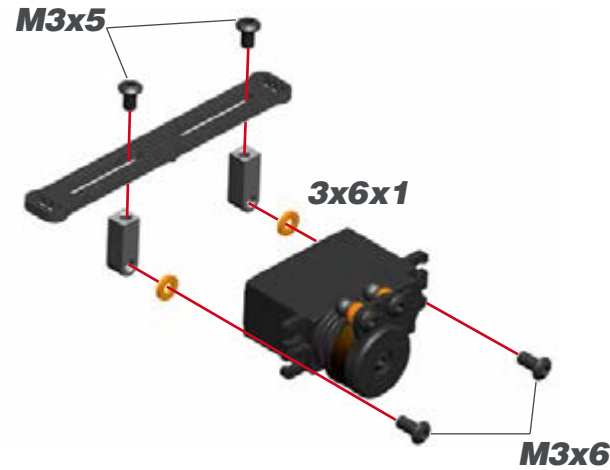

25.3

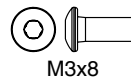
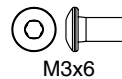
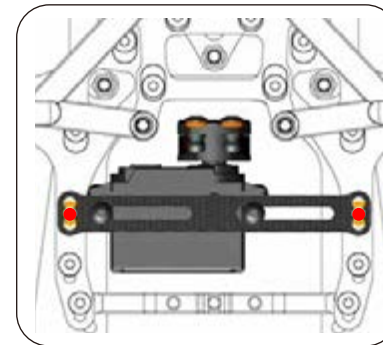
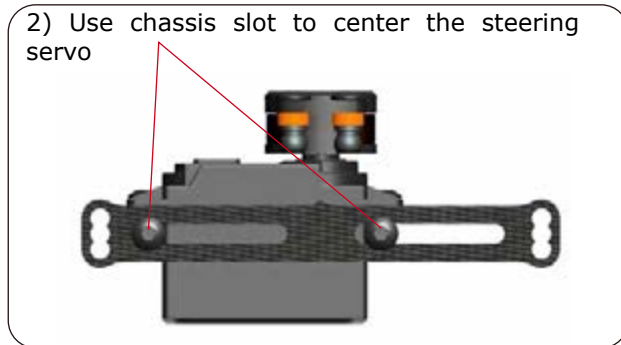
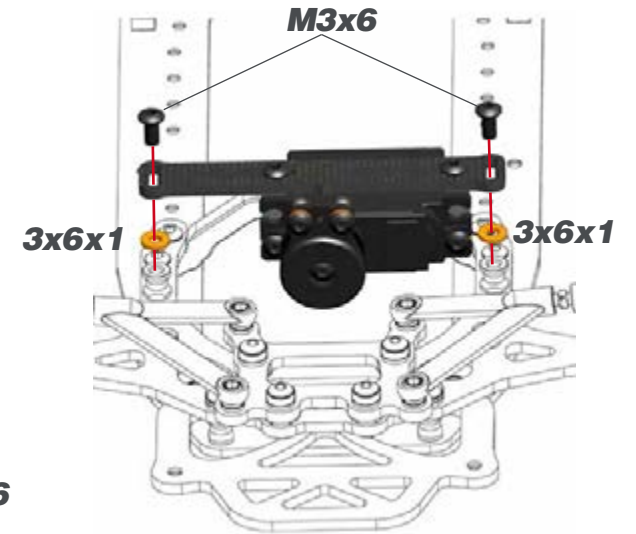

STEP 26

26.1

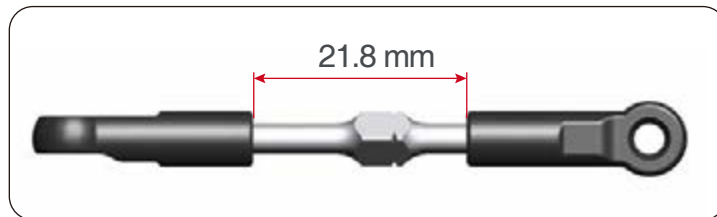

26.2

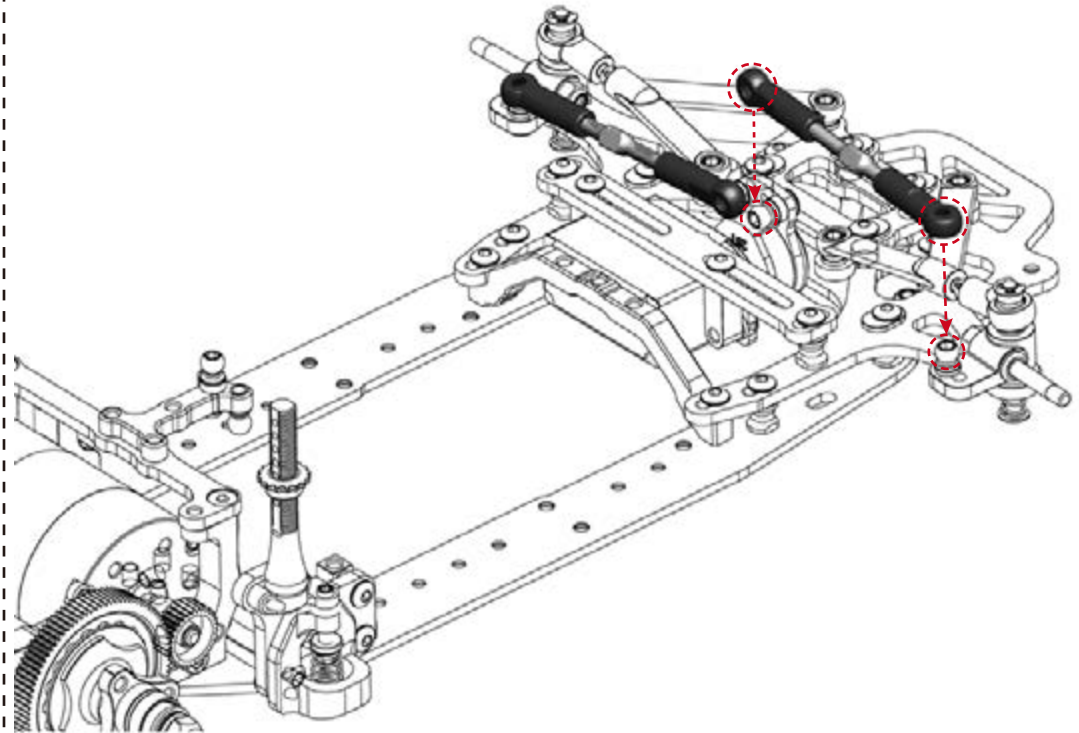

STEP 27

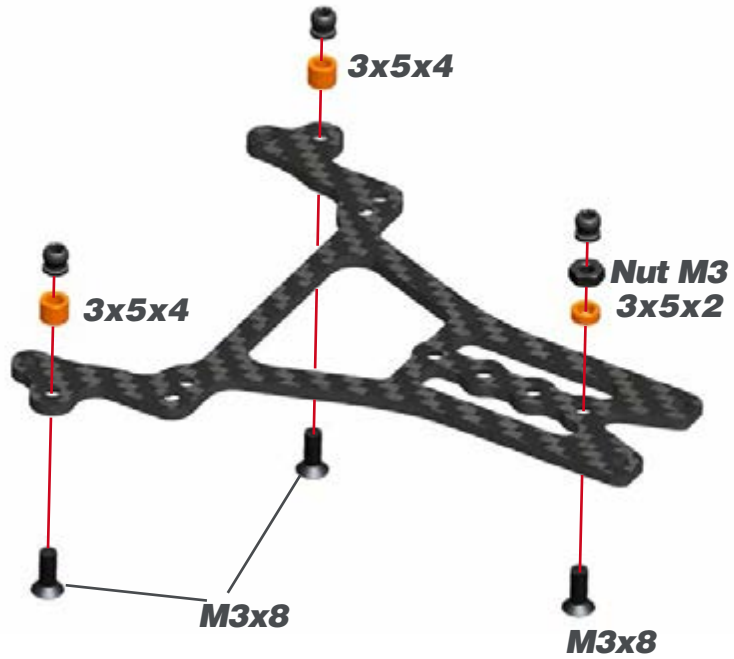

STEP 28

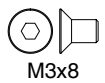
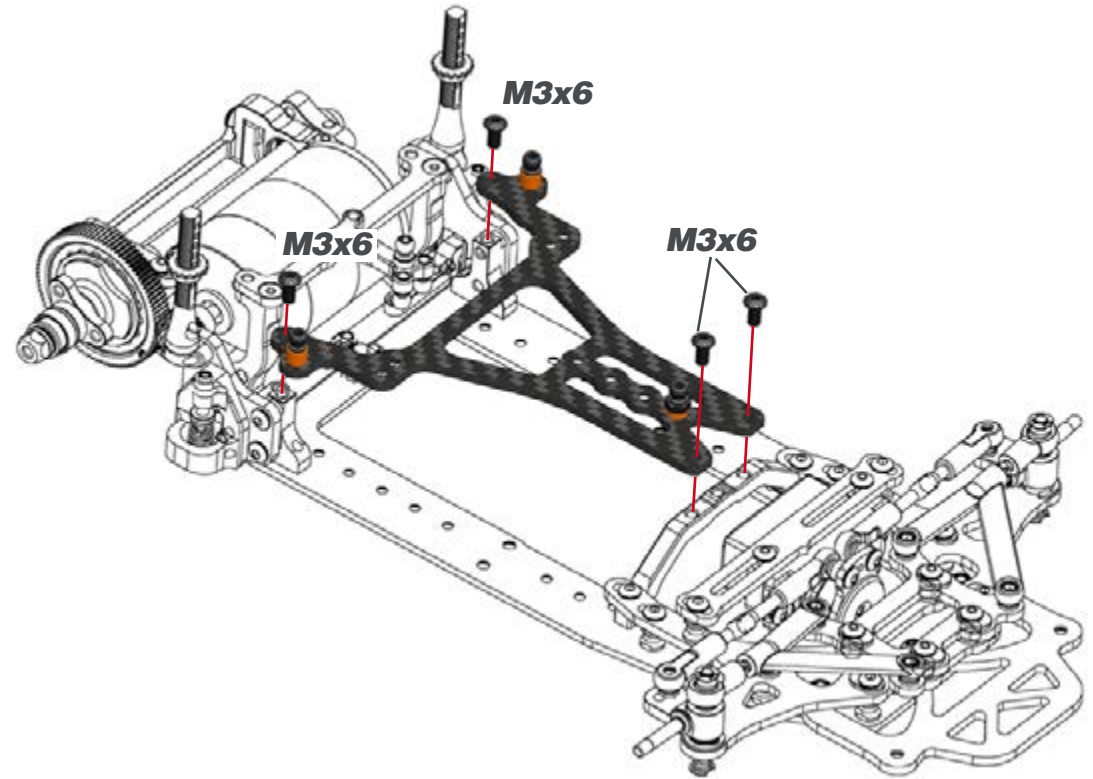

M3x8



Nut M3



3x5x2



3x5x4

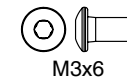

M3x6

STEP 29 BAG 7

29.2

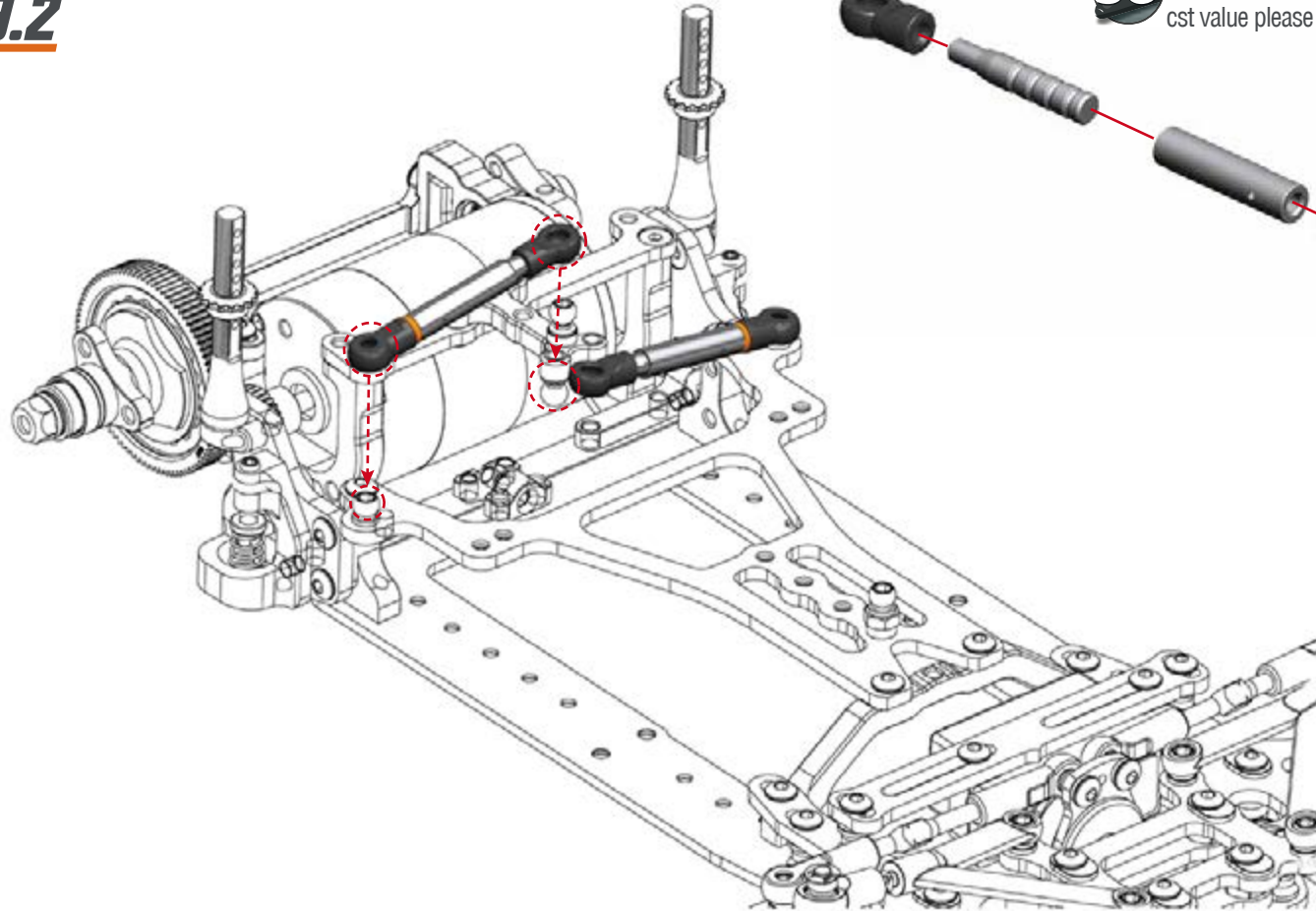

29.1

SO Apply the silicone oil on the inner tube. Use the silicone oil supplied in the kit. For the correct cst value please check the default setupsheet.



STEP 30

31.1

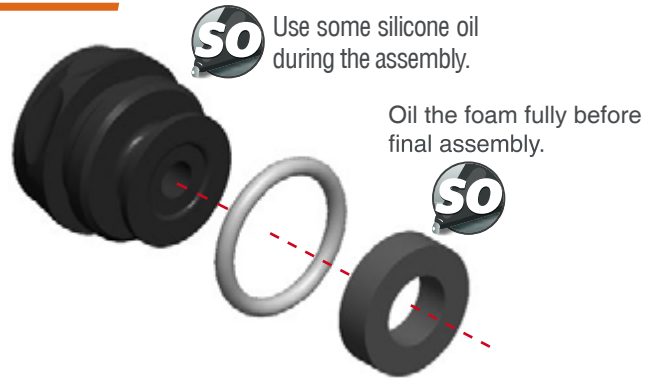

31.2

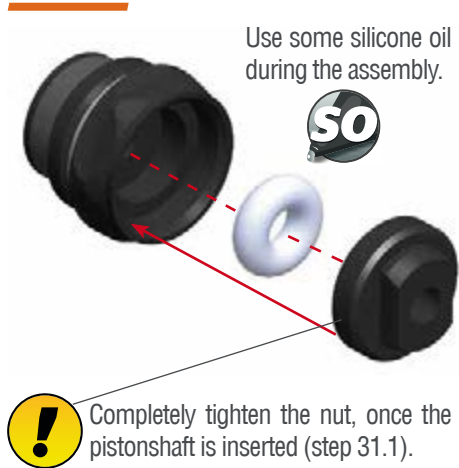

31.3

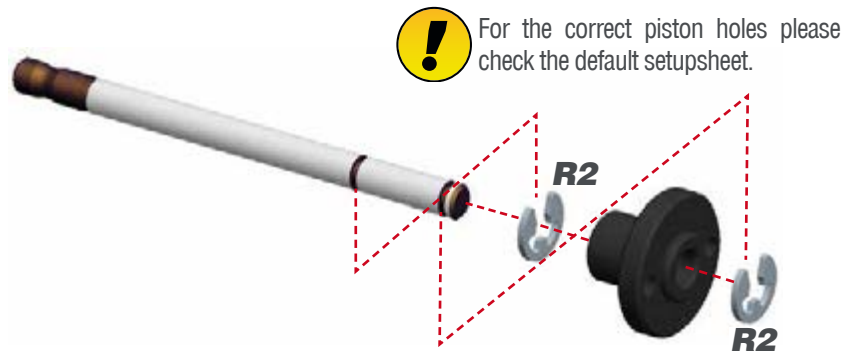

STEP 31

32.1

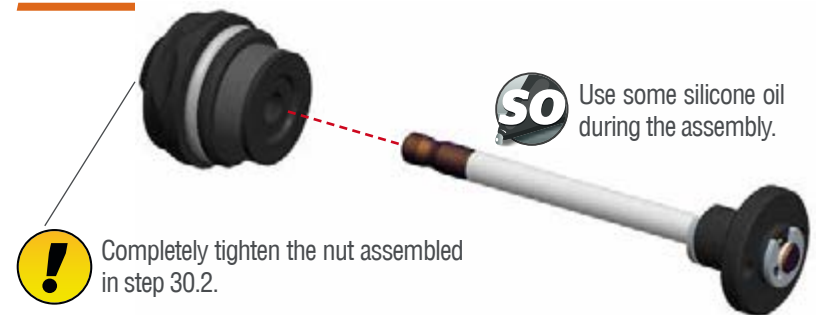

32.2

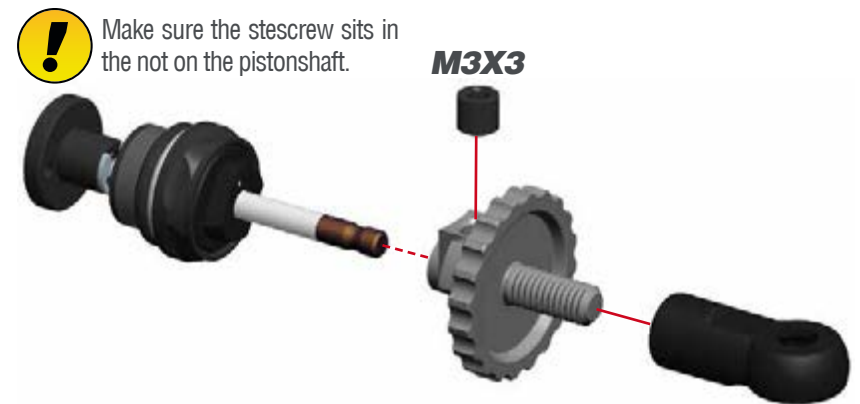

STEP 32

33.1

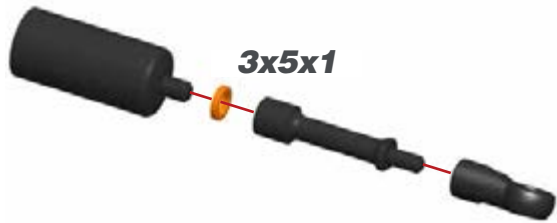

33.2

1) Fill the shock body with shock absorber oil. Check the oil CST value in the setup sheet.

2) Bleeding: Let the oil settle and allow the air to escape.



STEP 33

Close the shock slowly.

Important: do not crosstread! Oil will overflow through the built-in bleed channel.

Tighten carefully until the bottom half sits against the shock body.



STEP 34

35.1

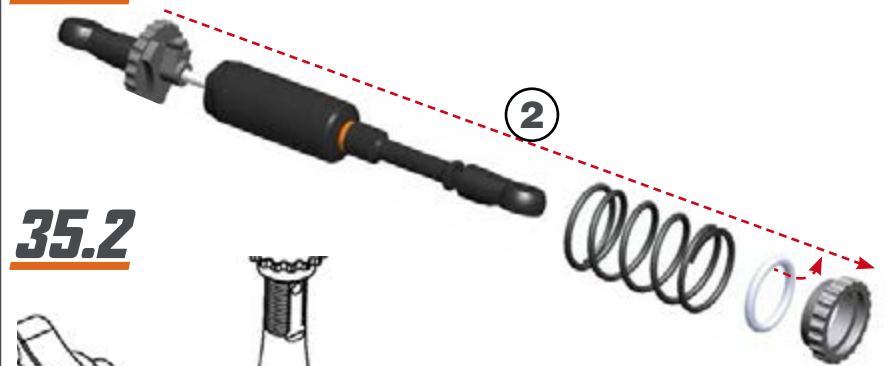

35.2

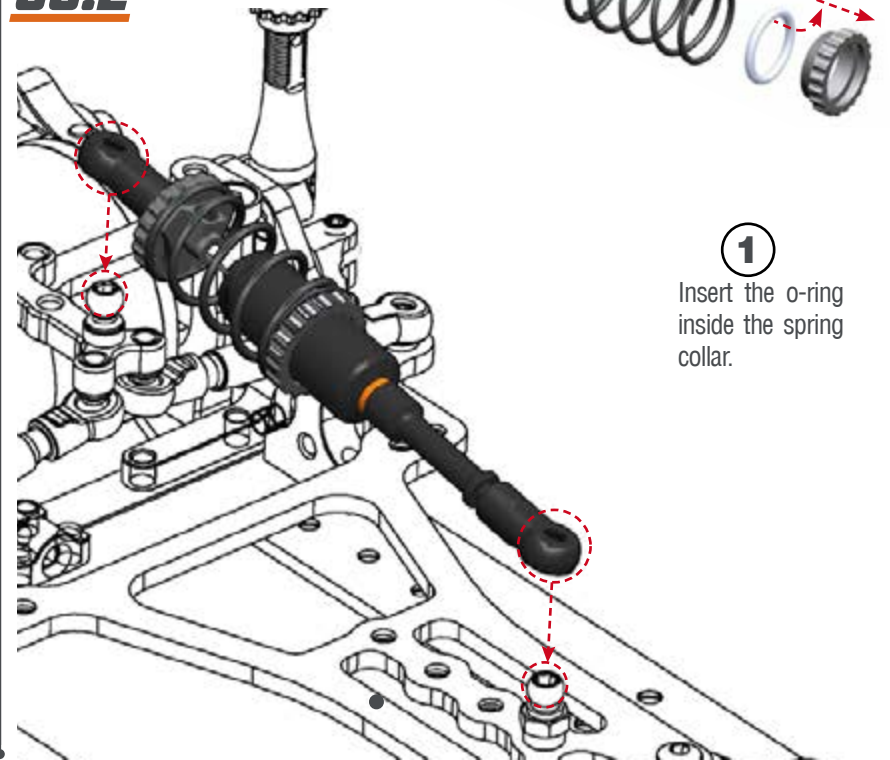

1) Insert the o-ring inside the spring collar.

STEP 35 BAG 8



Use double sided tape to mount the FANS to the chassis.

NI



Use narrow fans that don't touch the pod plate or the battery holder.

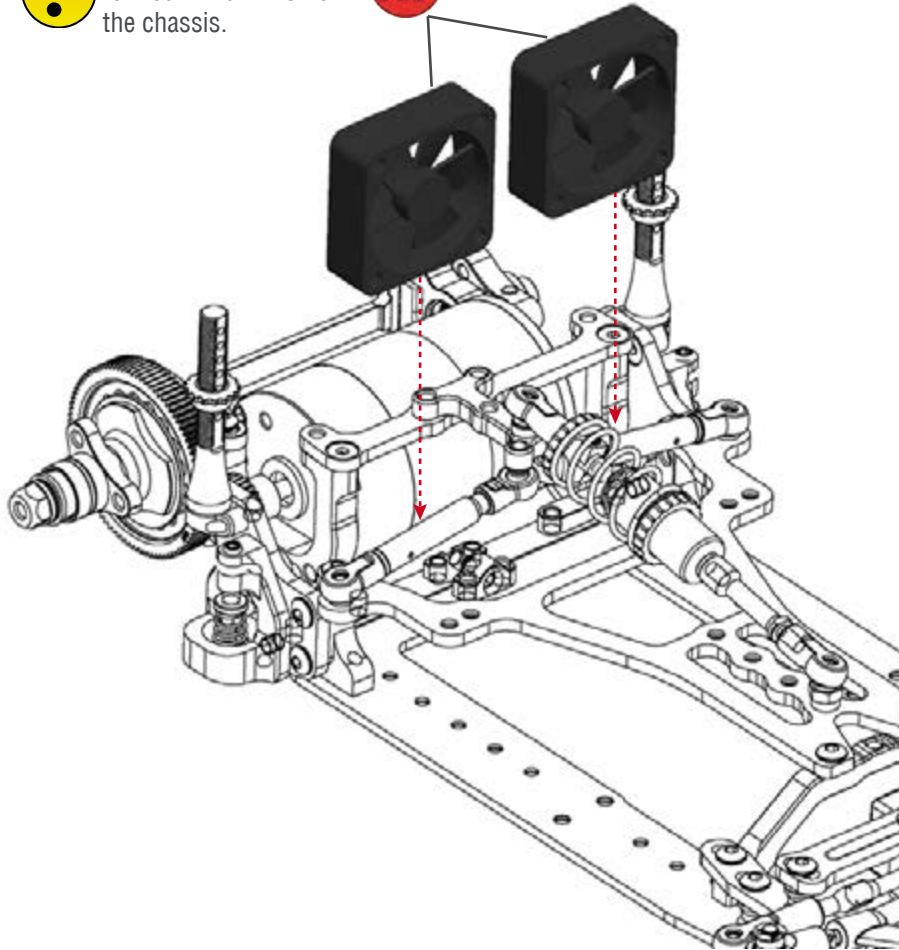

STEP 36

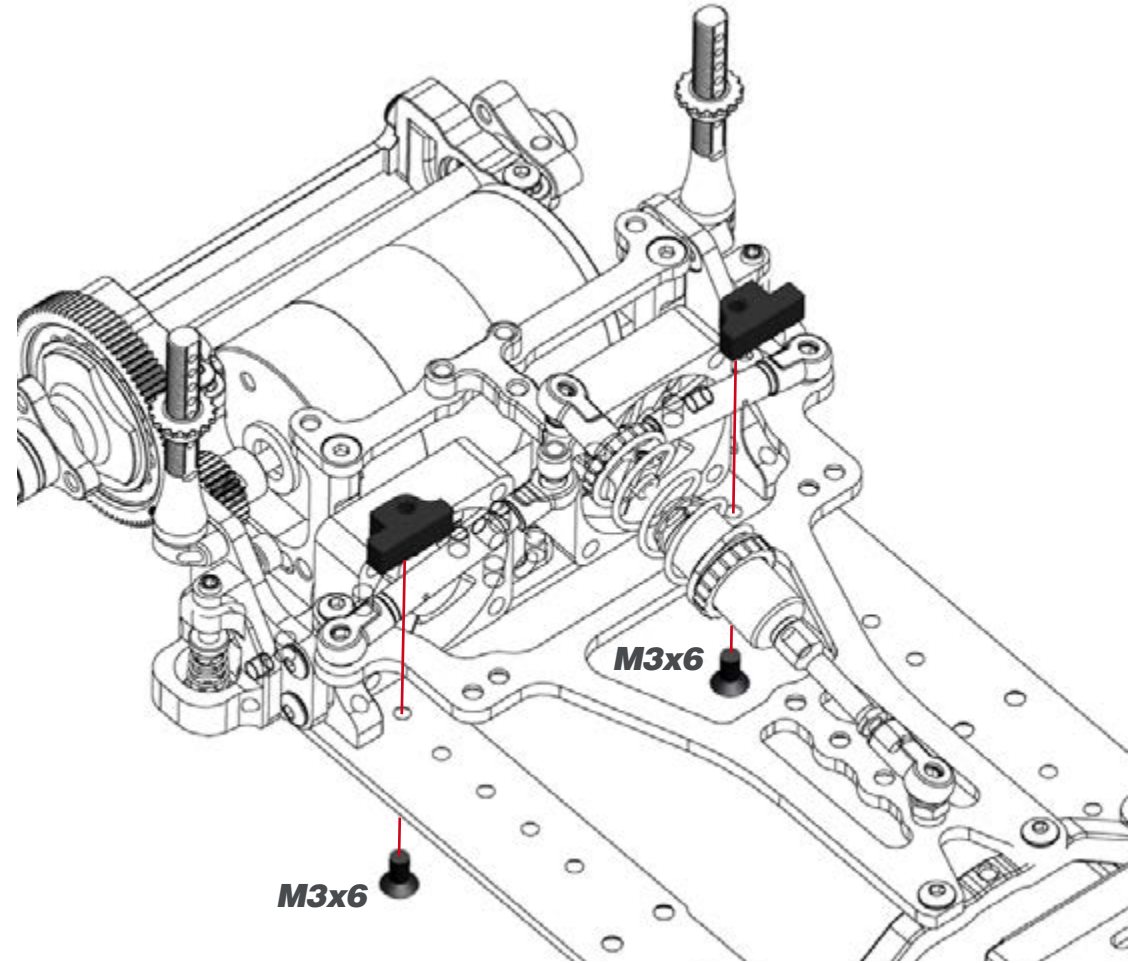

M3x6

STEP 37

LOW TRACTION CONFIGURATION **DEFAULT**

! recommended for low traction use (dusty asphalt, wet racing).

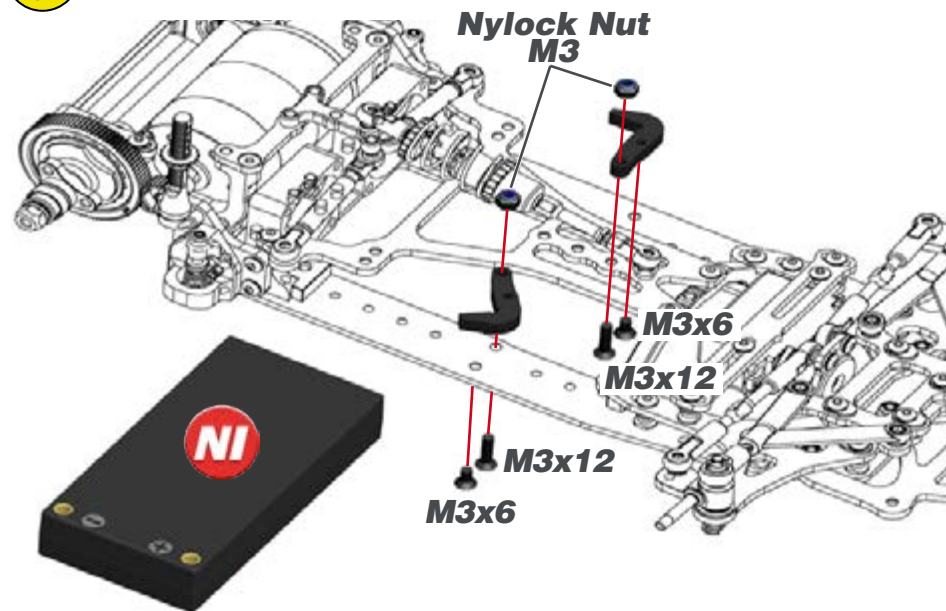

BATTERY MOUNT POSITION

To assemble the battery it is needed to remove the M3x6 screw and turn the battery holder. When the battery will be fitted assemble the M3x6 screw.

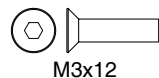

HIGH TRACTION CONFIGURATION **OPTIONAL**

! Recommended for general use.

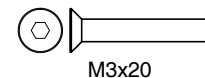
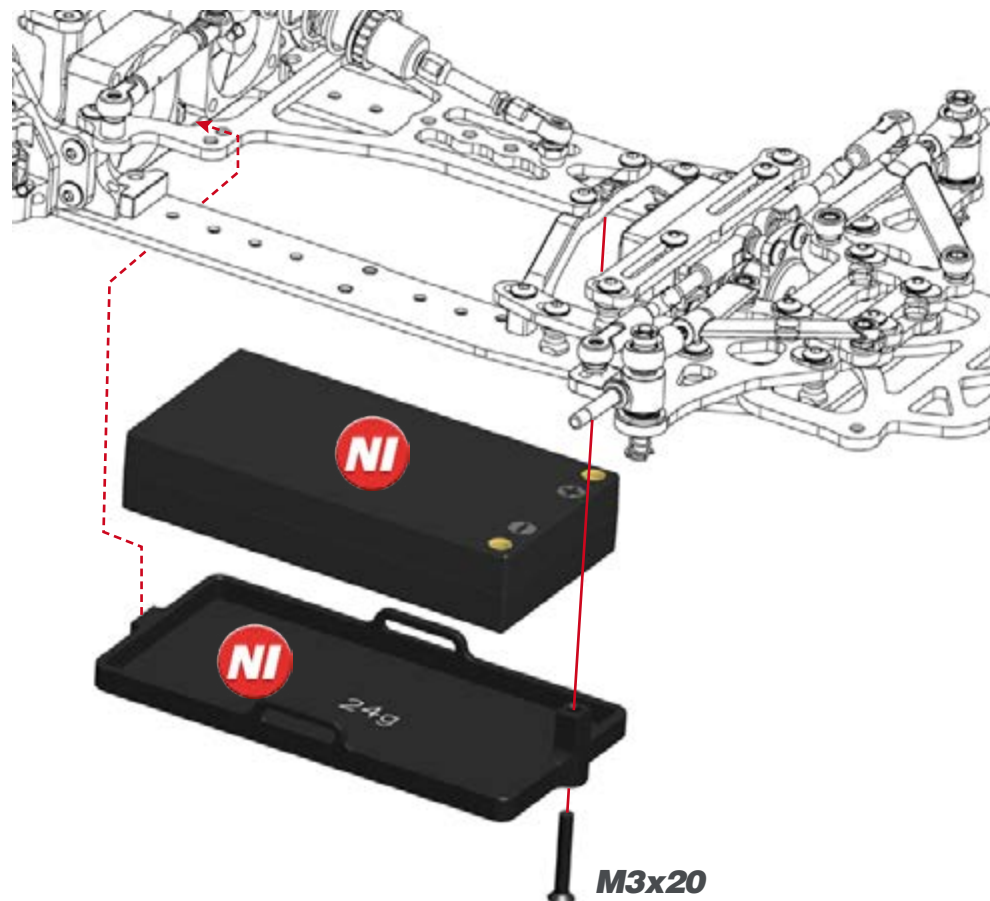

STEP 38

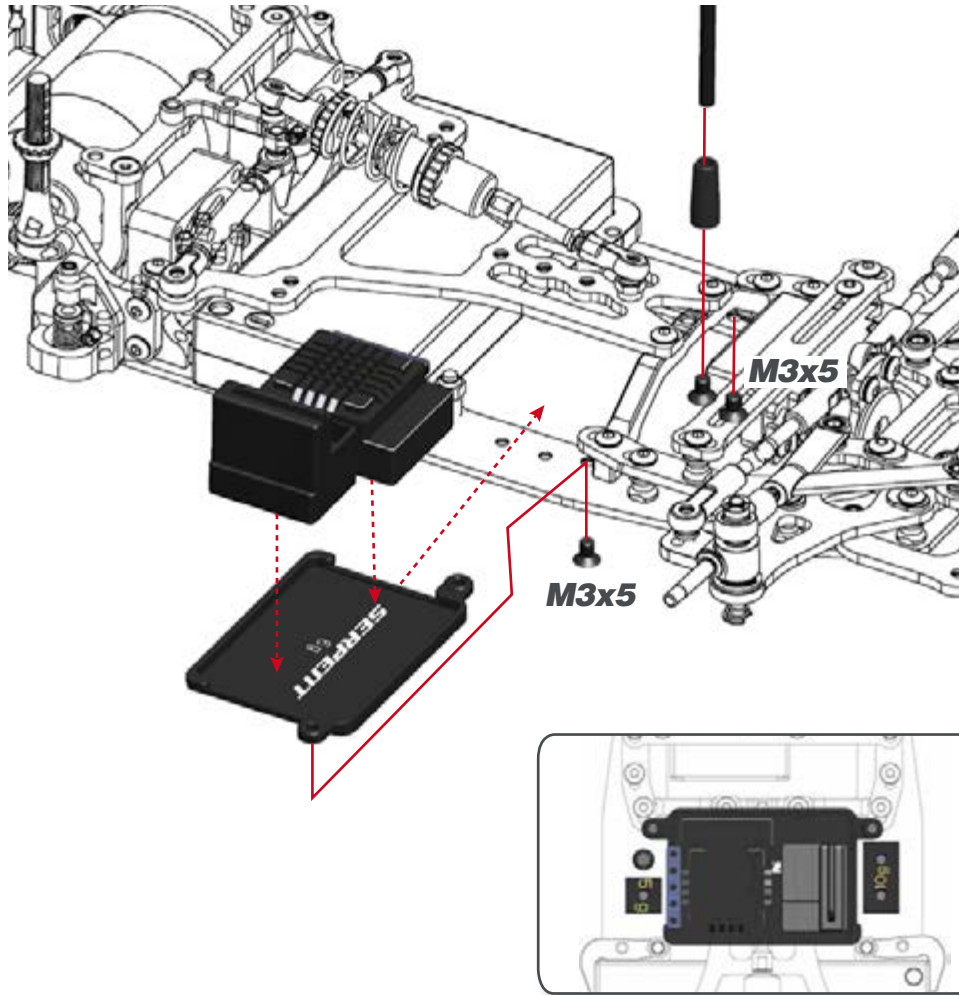

M3x5

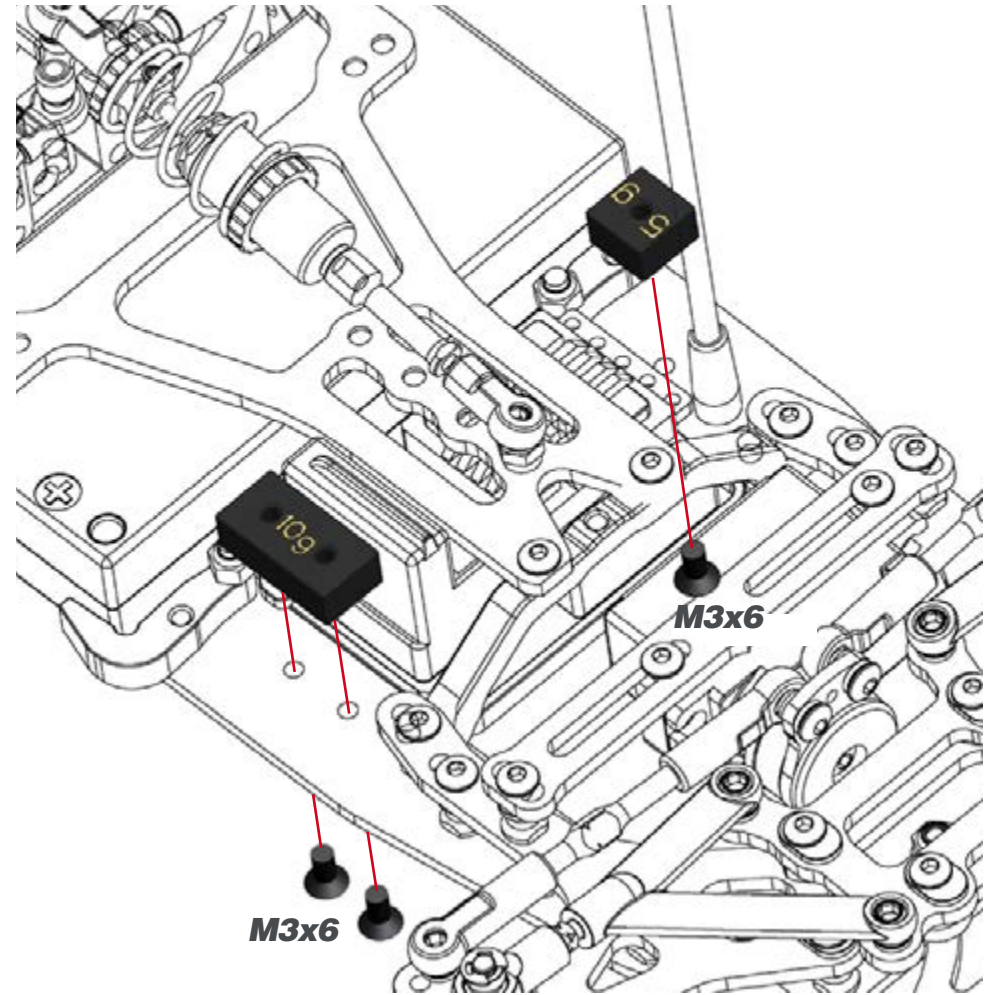

M3x6

STEP 39

! *OPTIONAL LAYOUT*

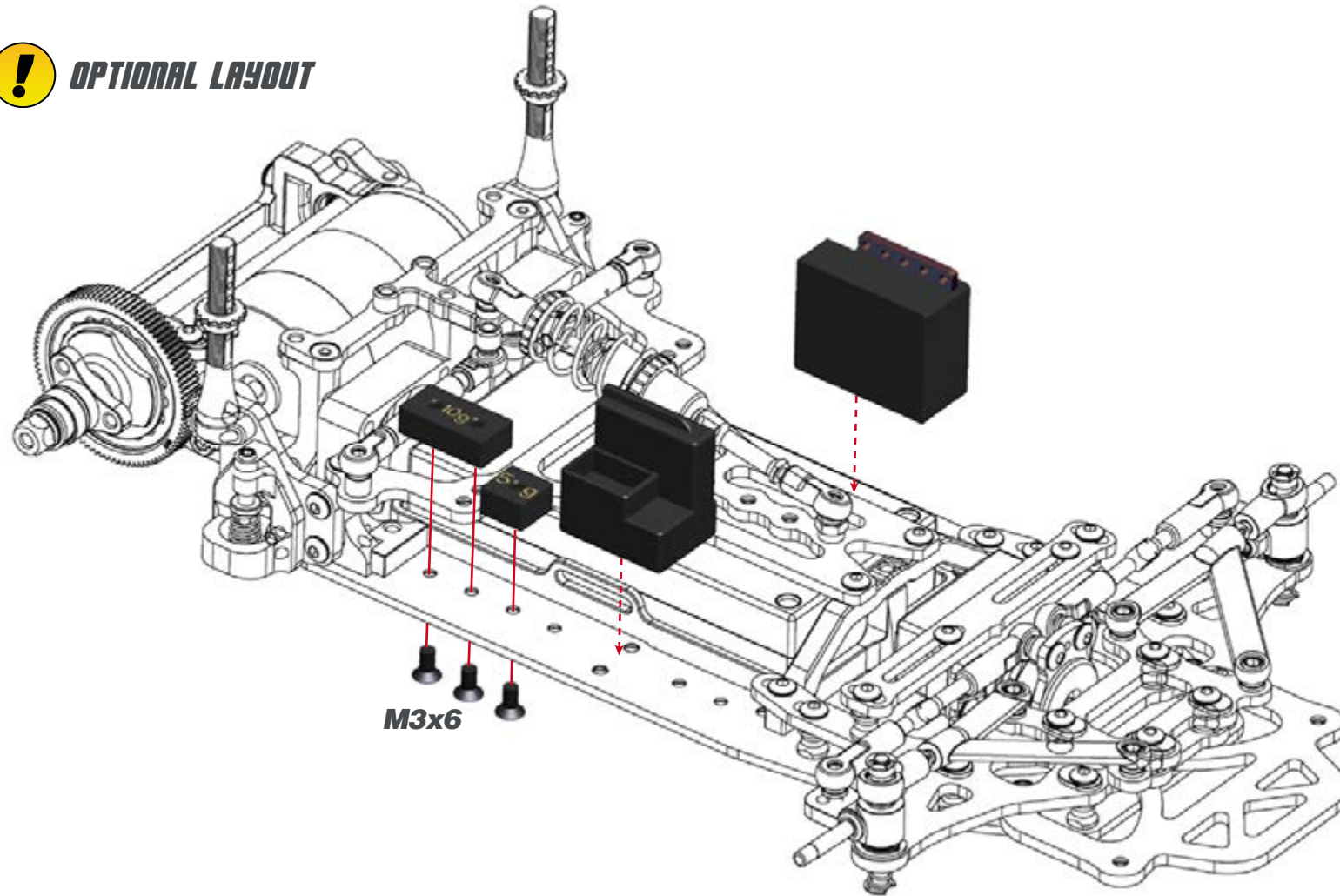

STEP 40

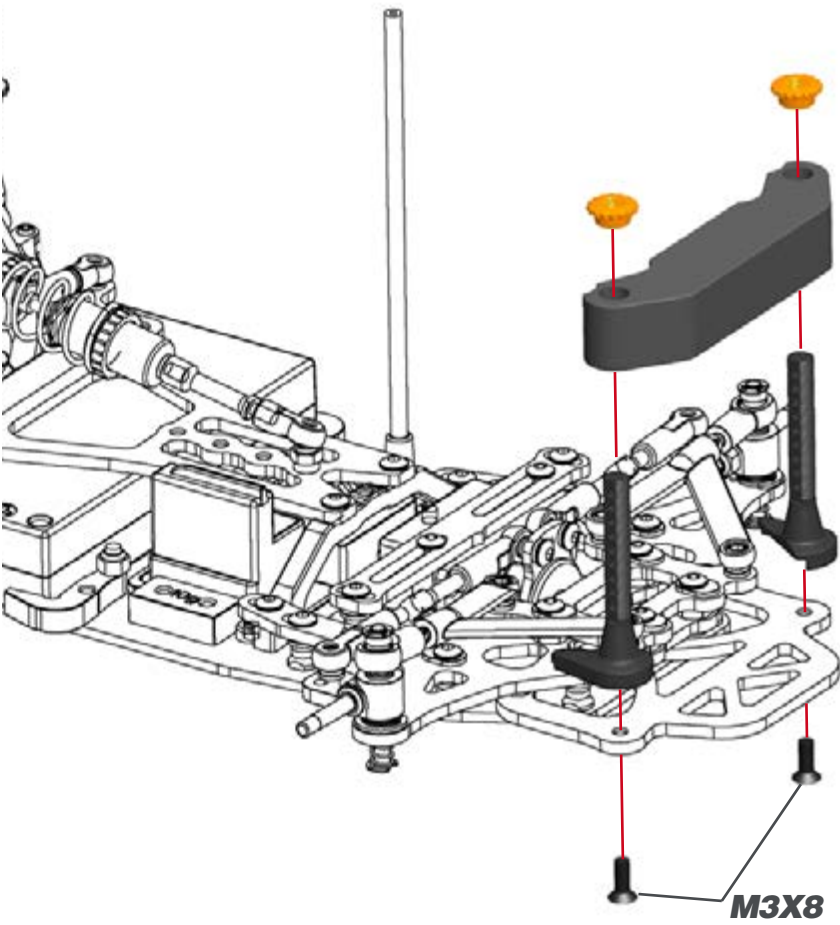

STEP 41

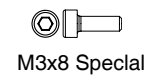
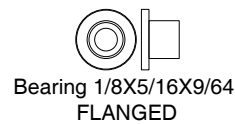
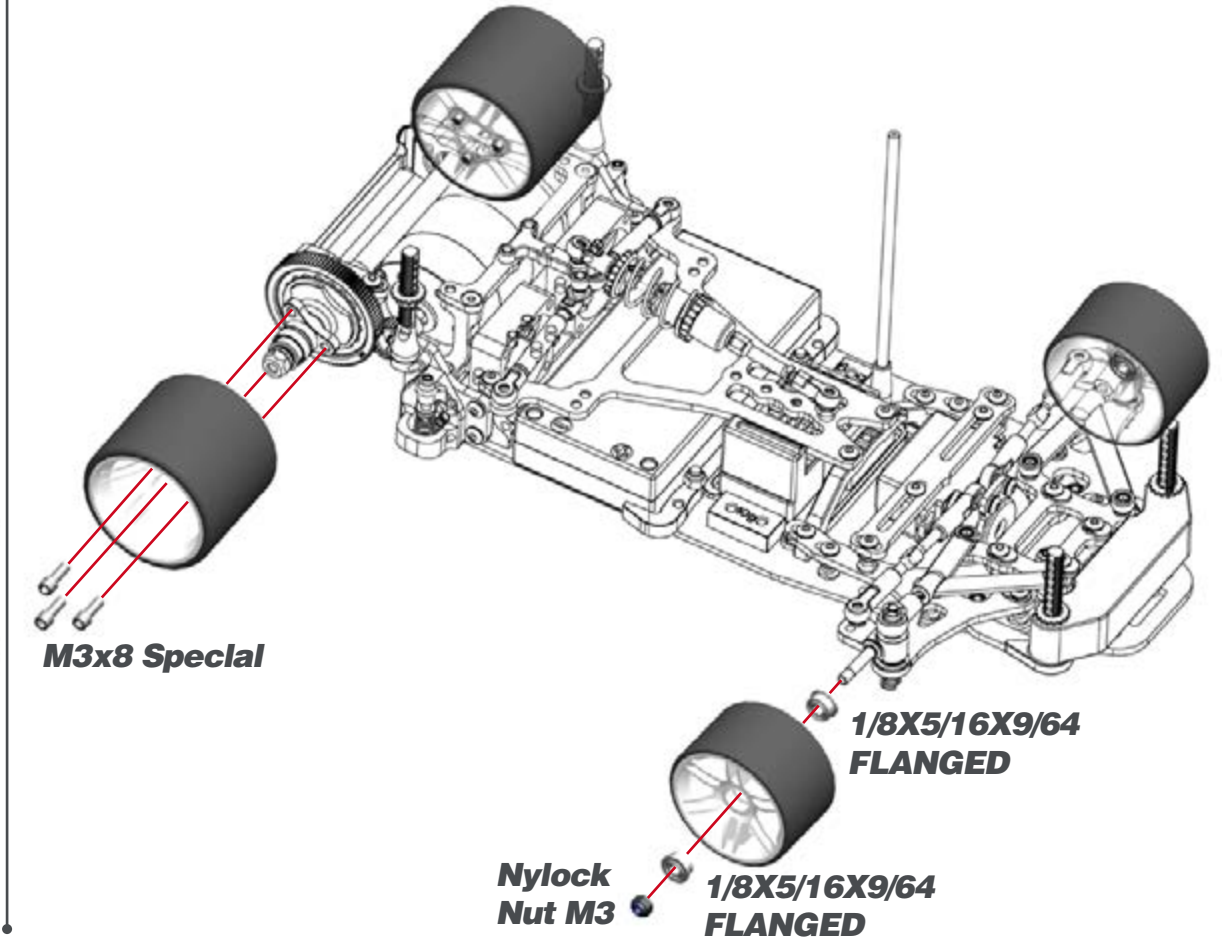

STEP 42

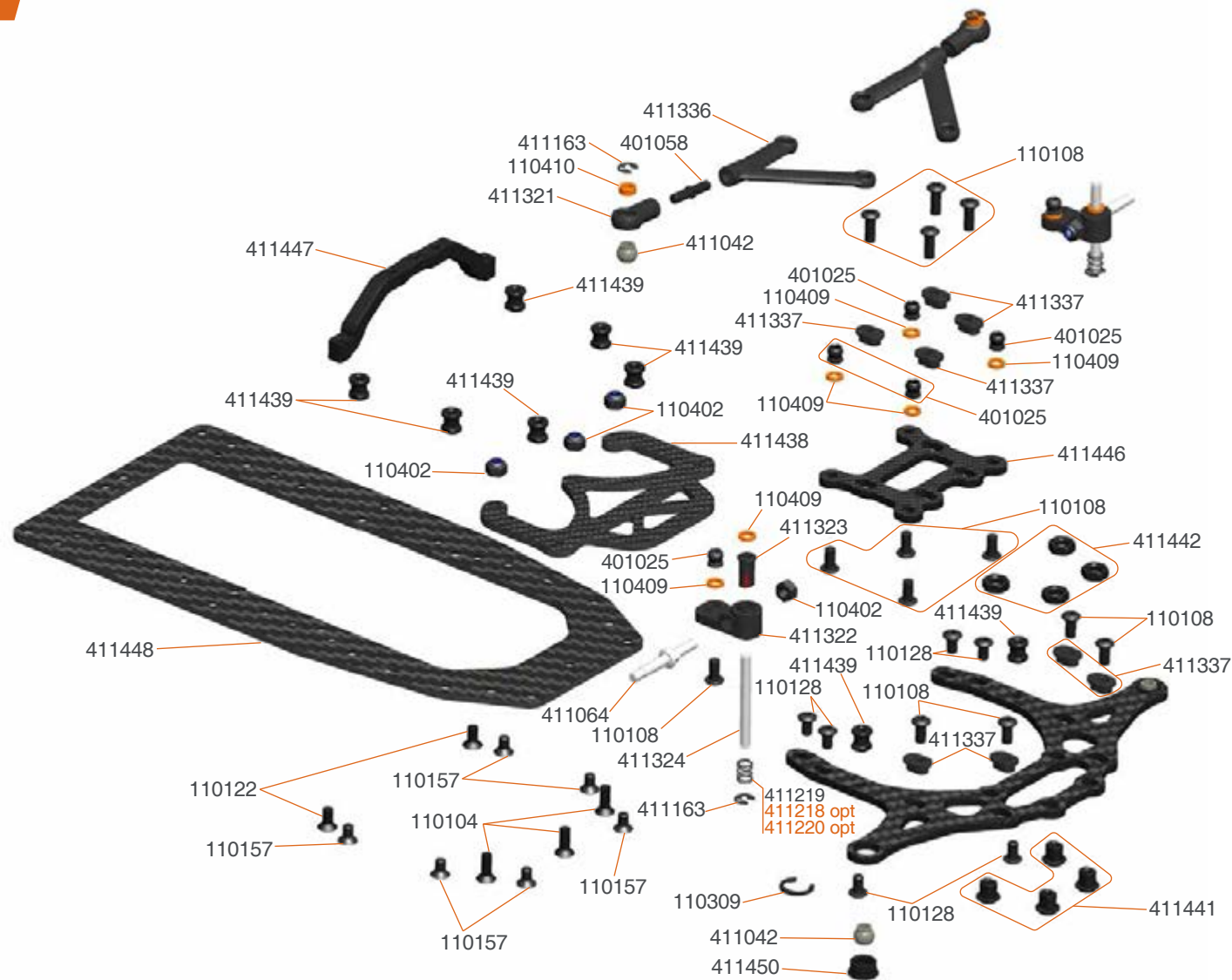

- 411218 Front spring 22lbs S120L (2)
- 411220 Front spring 26lbs S120L (2)



STEP 43

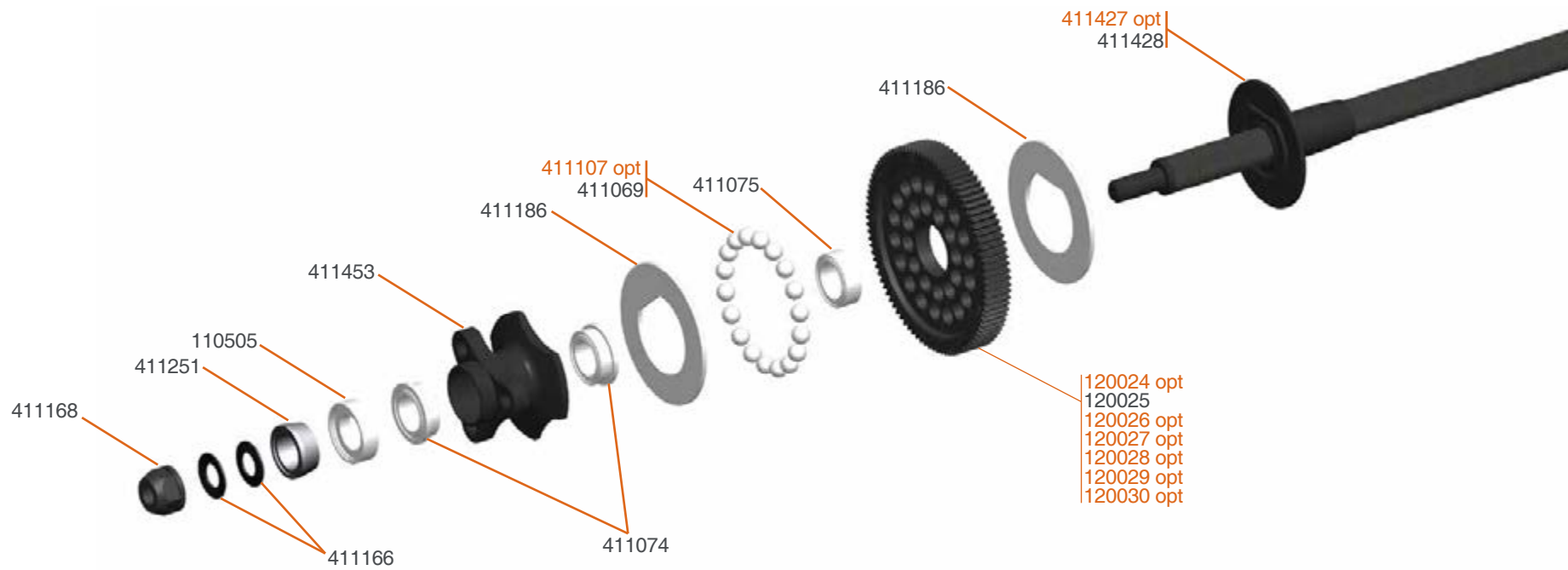

411107 Diff balls. 1/8 ceramic (12)
 411427 Rear axle alu F110 SF4

120024 Spur diff gear 64P/86T
 120026 Spur diff gear 64P/94T
 120027 Spur diff gear 64P/98T
 120028 Spur diff gear 64P/102T
 120029 Spur diff gear 64P/106T
 120030 Spur diff gear 64P/110T

STEP 44



411366 Center spring 6.5lbs
 411368 Center spring 10lbs

411214 Center spring 12lbs S120L
 411215 Center spring 14lbs S120L
 411216 Center spring 16lbs S120L
 411217 Center spring 18lbs S120L

STEP 45

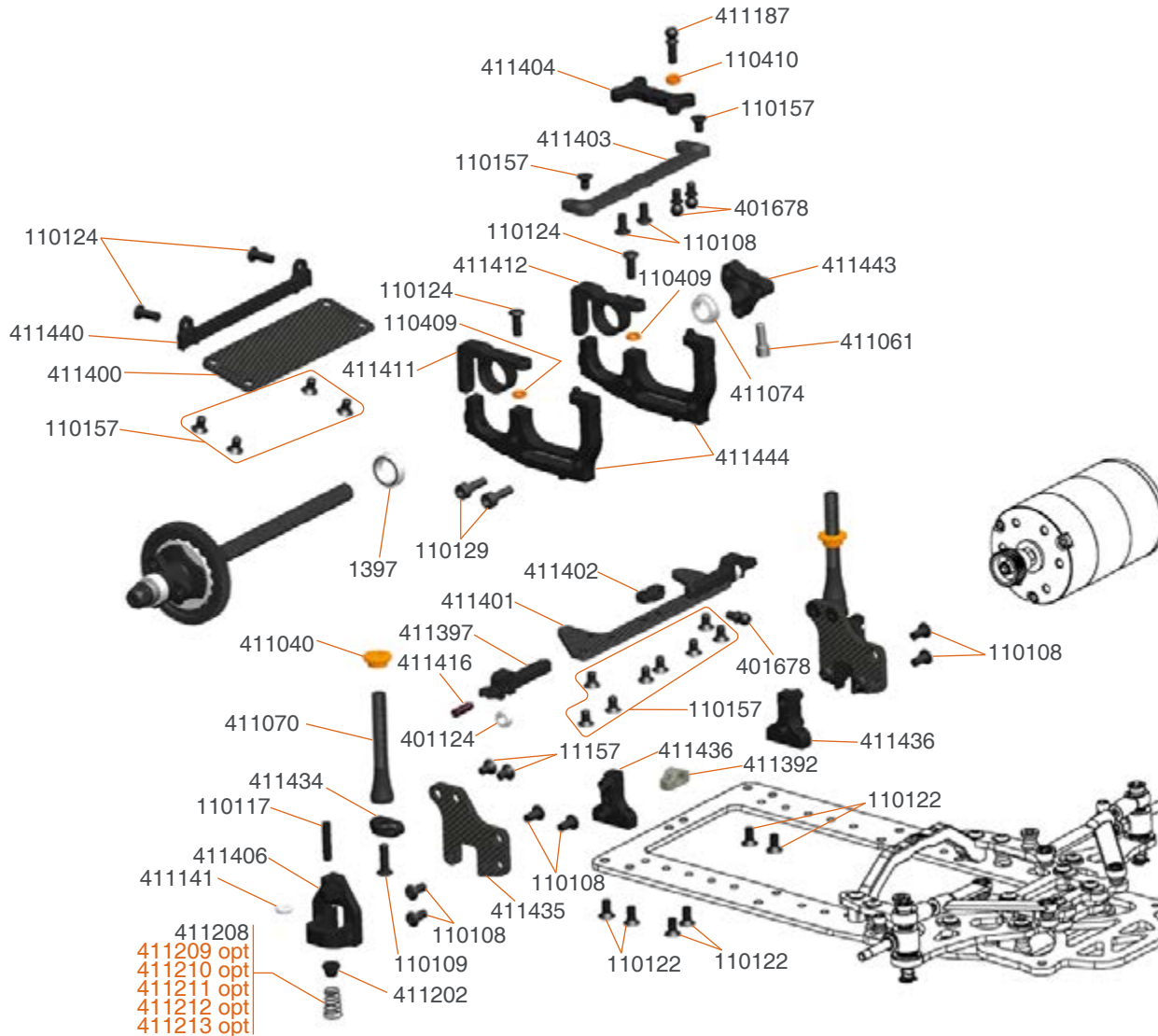

- 411209 Side spring 5.0lbs S120L (2)
- 411210 Side spring 5.5lbs S120L (2)
- 411211 Side spring 6.0lbs S120L (2)
- 411212 Side spring 6.5lbs S120L (2)
- 411213 Side spring 7.0lbs S120L (2)

STEP 47

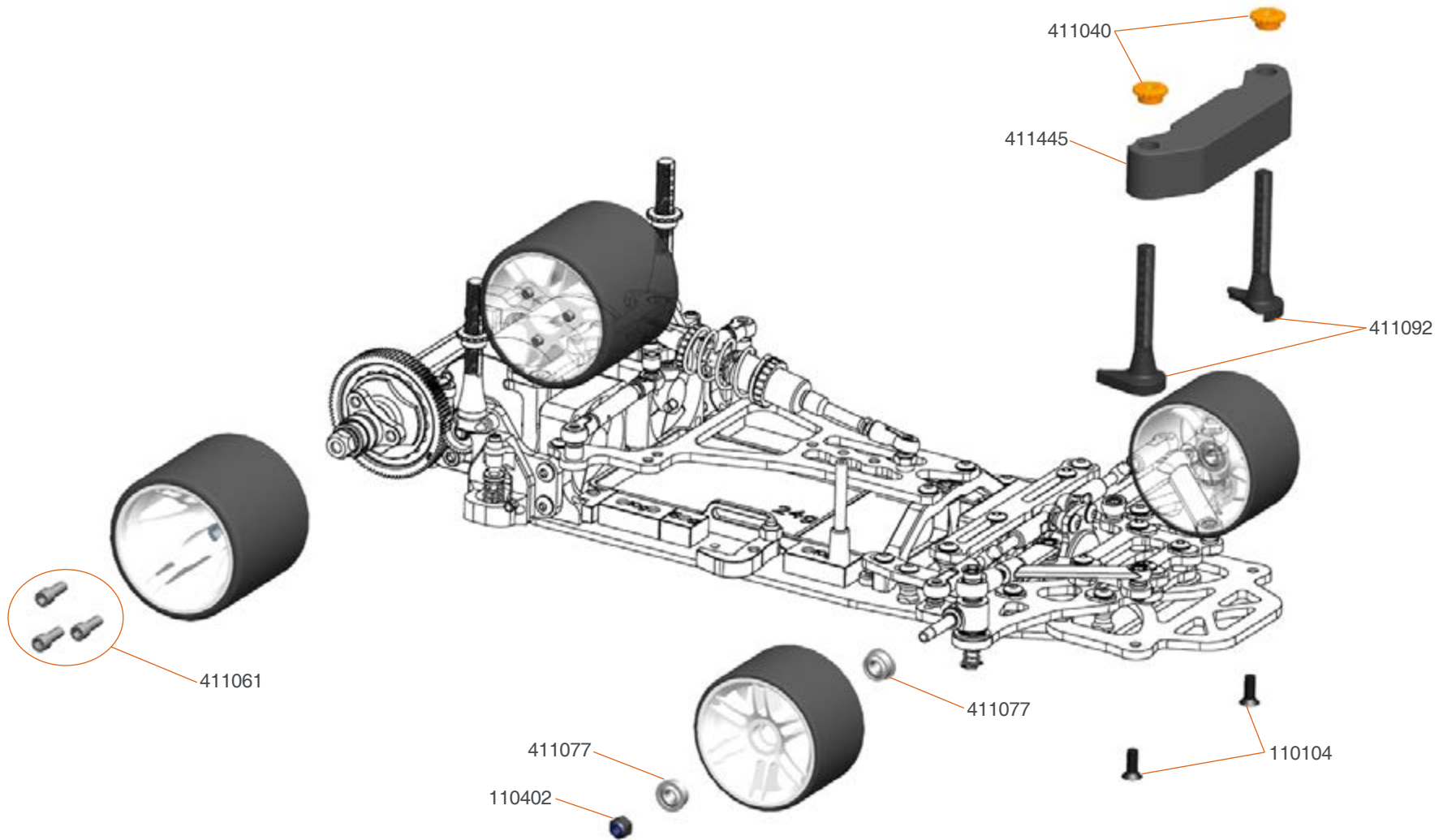

TEAM SERPENT NETWORK

120 PRO SPARE PARTS www.serpent.com/410067/spares/

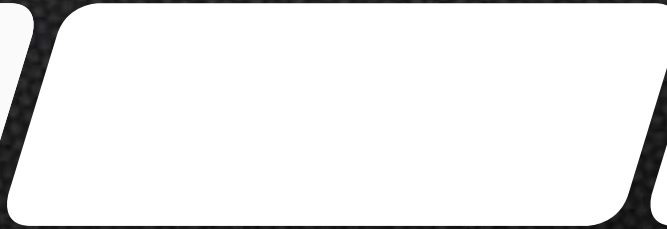
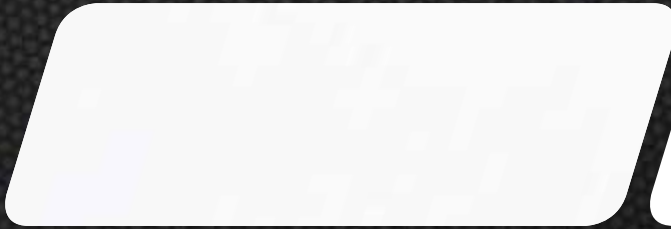

120 PRO OPTIONALS PARTS www.serpent.com/410067/Optionals/

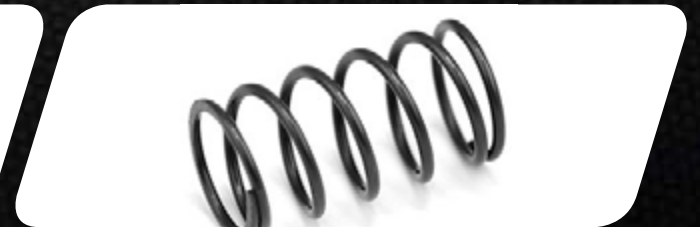

SERPENT TOOLS www.serpent.com/product/Tools/



SERPENT MERCHANDISING www.serpent.com/product/Merchandising/



SERPENT WEBSITE AND BLOG

www.serpent.com
www.teamserpent.com
www.dragon-rc.com

SERPENT PROMO PAGES <http://promo.serpent.com>

SERPENT FACEBOOK GROUPS <http://promo.serpent.com/indexfb.htm>

SERPENT ADVANCED MANUALS <http://promo.serpent.com/sam/>

SERPENT SOCIAL MEDIA



www.facebook.com/SerpentMRC



www.youtube.com/user/SerpentMRC



www.twitter.com/SerpentMRC



www.plus.google.com/+SerpentModelcars/posts



www.weibo.com/teamserpent

INSTRUCTION MANUAL

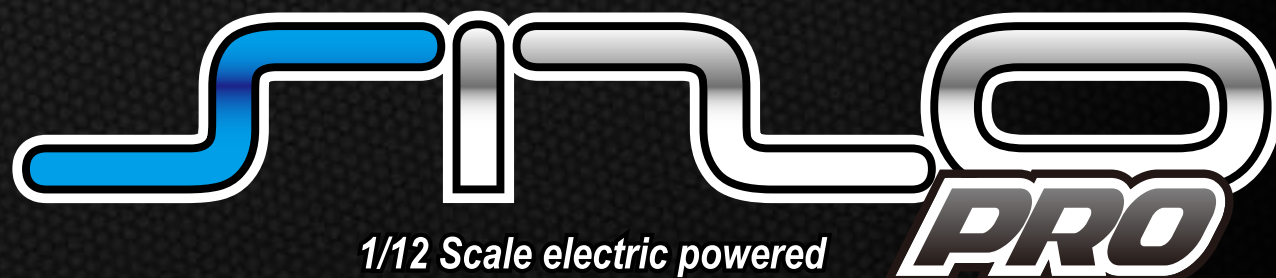

1/12 Scale electric powered

PRO



Manual S120 PRO #80900-1

SERPENT