

# X20'23

*1/10 SCALE ELECTRIC TOURING CAR*

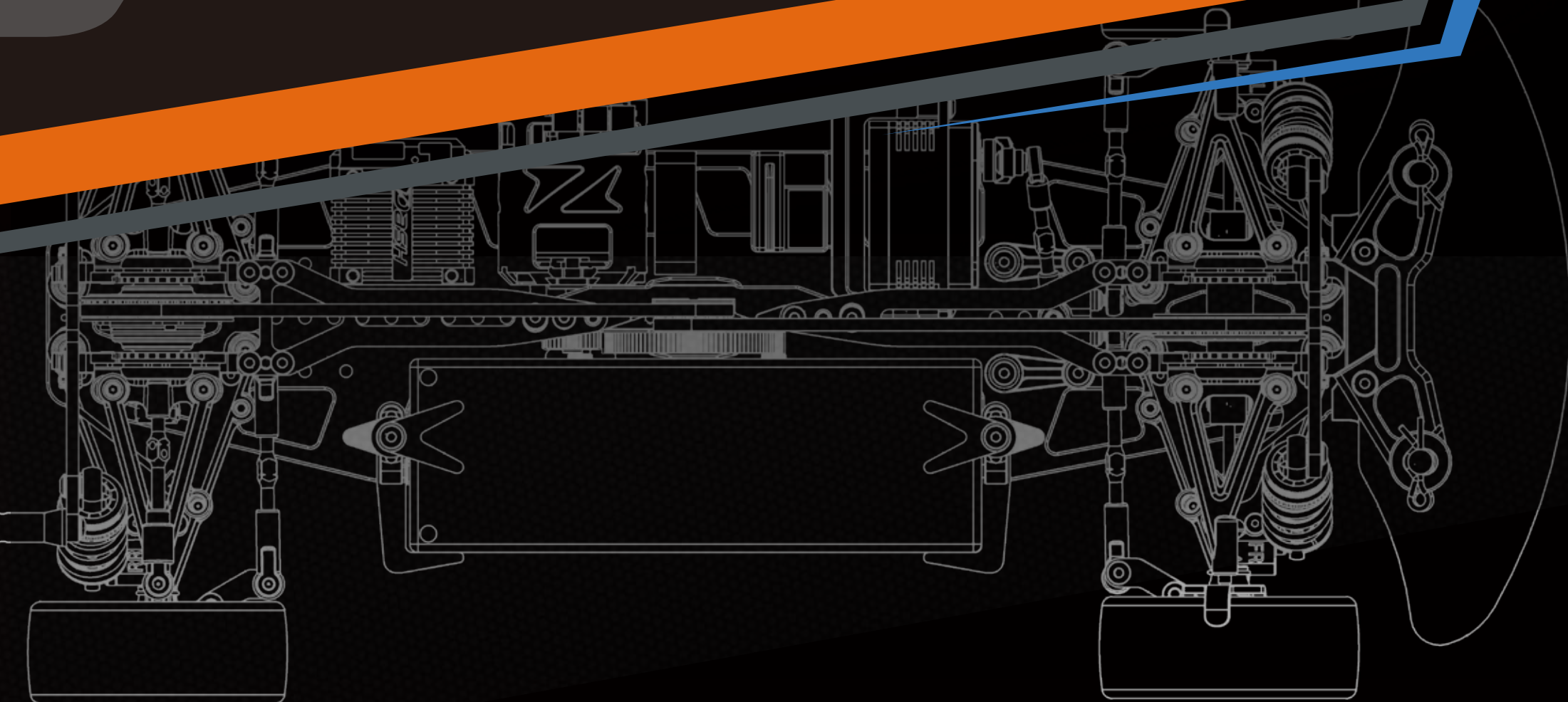

**SERPENT**

## INTRODUCTION

Thank you very much for selecting this Serpent rc car and thus become a member of the ever growing worldwide Serpent racing family. Serpent started in 1980 and has been growing its product-line and fan-base ever since.

The Serpent X20'23 mEdius is a state of the art 1/10 scale 4WD touringcar which will give you the true Serpent racing experience. The assembly manual will guide you through all the steps to complete the car, so you can hit the track with a good base-set-up soonest. The Serpent design department succeeded to create a superbly performing car combined with eas of assembly and maintenance. The high quality standards of all parts and hardware will make racing your Serpent car a very rewarding activity!

Through our team, website and social media we will keep you up-to-date on all developments of the Serpent cars. We hope to meet you on the track and through our various media! Enjoy the drive!

Team Serpent  
Multiple World Champions

## INSTRUCTIONS

Serpent's long tradition of excellence extends to the instruction manuals, and this instruction manual is no exception. The easy-to-follow layout is richly illustrated with 3D-rendered full-color images to make your building experience quick and easy. Following the instructions will result in a well-built, high-performance race-car that will soon be able to unleash its full potential at the racetrack. The kit includes bags, with bagnumbers, which refer to the same step in the manual. Open only the indicated bag(s) per step and finish that part of the assembly. Remaining parts will be needed lateron in the assembly process.

## PLASTIC PARTS

The Serpent moulded parts are very durable and hard. When assembling longer screws in new composite parts, make sure to use new hex bits in your (power) tools. Pre-threading also helps to avoid screw damage.

## SETUP

In certain assembly steps you need to make basic adjustments, which will give you a good initial setup for your Serpent X20'23 mEdius. Fine-tuning the initial setup is an essential part of building a high-performance racecar like your Serpent

## EXPLODED VIEWS AND PARTS LIST

The exploded views and parts lists for the X20'23 mEdius are presented in the Reference Guide section in the back of this manual. The exploded views show all the parts of a particular assembly step along with the Serpent part number and hotlink to the Serpent website. Partnumbers in orange indicates that this part is an optional. Optionals part names and numbers are showed below.

## CUSTOMER SERVICE

Serpent has made a strong effort to make this manual as complete and clear as possible. Additional info may be published in our website: [www.serpent.com](http://www.serpent.com) or you may ask your dealer or the Serpent distributor for advice, or email Serpent direct: [info@serpent.com](mailto:info@serpent.com). The Serpent Facebook, Twitter and Youtube pages give additional means of support and communications.

## SAFETY

Read and take note of the 'Read this First section' before proceeding to assemble the car-kit. This car-kit is intended for persons aged 16 or older.

## READ THIS FIRST!

- This is a highly technical hobby product, intended to be used in a safe racing environment. This car is capable of speeds in excess of 80 km/h or 50mph. Please follow these guidelines when building and operating this model.
- Parental guidance is required when the builder/user of this car is under 16.
- Follow the building instructions. If in doubt, contact your dealer or importer.
- Be sure to use the proper tools when assembling the car. Always exercise caution when using electric tools, knives and other sharp objects.
- Be careful when using liquids like lubrication oil, fuel or glue. Do not swallow.
- Follow the manufacturer's instruction in case you experience irritation after using the product.
- Be careful when operating the car. Stay away from any rotating parts such as wheels, gears and transmission. Stay away from motor, engine and exhaust pipe system or speedo during and immediately after use, as these parts may be very hot. We advise to use protective hand cloves.
- Only operate this car in a safe environment, like a special racing track or a closed parking lot. Avoid using this car on public roads, crowded places or near infants.
- Before operating this car, always check the mechanical status of the car. Also check that the transmitter and receiver frequencies correspond and are not used by any other racer at the same time. Check that the batteries of the transmitter and receiver- are fully charged.
- After use, always check all the mechanics of the car. We advise to clean the car immediately after use, and inspect the parts for wear or fractures. Replace when necessary. Do not use water, methanol, thinner or other solvents to clean the car.
- Empty the fuel tank (depending on model) if needed and disconnect the receiver battery.
- Store the car in a dry and heated place to avoid corrosion of metal parts.
- Avoid using this car in wet conditions as the water will cause corrosion on the metal parts and bearings and these parts will cease to function properly. If driven in the wet, ensure that all the electric equipment is waterproofed and after use, that all moving parts are dried immediately.

## CONTENTS

• <b>DIFF ASSEMBLY</b> .....	<b>4</b>
• <b>DJC ASSEMBLY</b> .....	<b>6</b>
• <b>CVD ASSEMBLY</b> .....	<b>7</b>
• <b>FRONT &amp; REAR ASSEMBLY</b> .....	<b>8</b>
• <b>MOTORMOUNT ASSEMBLY</b> .....	<b>11</b>
• <b>REAR ASSEMBLY</b> .....	<b>13</b>
• <b>FRONT ASSEMBLY</b> .....	<b>18</b>
• <b>ANTIROLLBAR ASSEMBLY</b> .....	<b>21</b>
• <b>STEERING ASSEMBLY</b> .....	<b>22</b>
• <b>CENTRAL ASSEMBLY</b> .....	<b>25</b>
• <b>SHOCK ASSEMBLY</b> .....	<b>28</b>
• <b>BUMPER ASSEMBLY</b> .....	<b>31</b>
• <b>FINAL ASSEMBLY</b> .....	<b>33</b>
• <b>EXPLODED VIEWS</b> .....	<b>37</b>
• <b>TEAM SERPENT NETWORK</b> .....	<b>48</b>

## LINES DESCRIPTION

Each step contains a variety of numbers, lines, and symbols. The numbers represent the order in which the parts should be assembled. The lines are described below.



Step number; the order in which you should assemble the indicated parts



Length after assembly



Assembly path of one item into another



Group of items (within lines) should be assembled first



Direction the item should be moved



Glue one item to another



Press/insert one item into another



Connect one item to another



Gap between two items

## ICONS DESCRIPTION

Each step contains a variety of symbols described below.



Carefull, read and check very well.



Apply a small amount of cyano glue. Use wear protection for eyes and hands.



Detail view to explain assembly or order of parts better.



Default set-up: This symbol indicates the default setup.



Grease: apply a small amount of grease to the parts shown.



Left and right parts should be assembled in the same way.



Thread lock: apply a small amount on the parts shown. Before to apply the threadlock, make sure to degrease the parts very well, as otherwise the threadlock will not work.



Silicone oil: use the indicated silicone oil for the shocks and differentials.



Parts or items not included in the kit.



Optional part, not standard in the kit.



## STEP 1 DIFF BAG

### 1.1

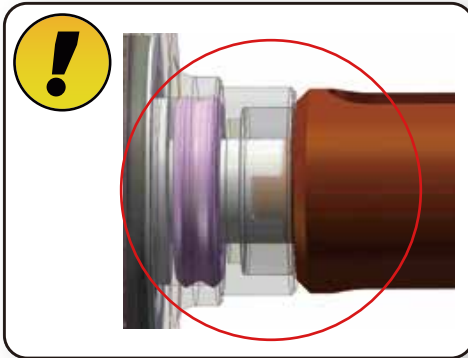
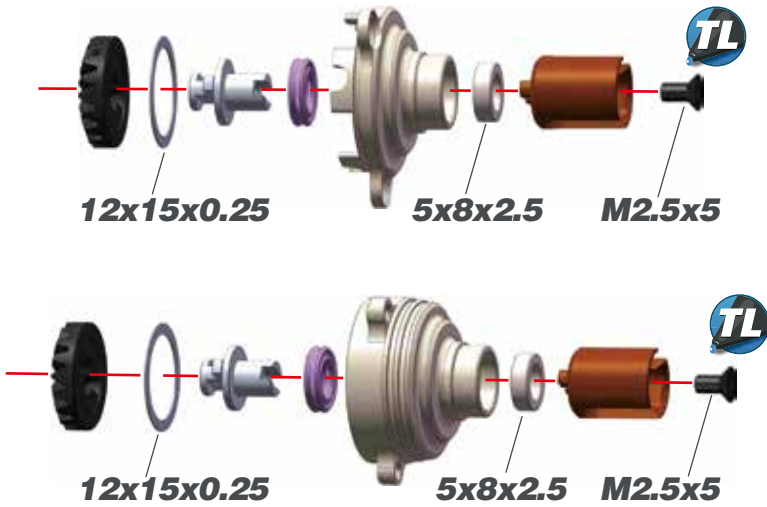

### 1.2



#### AMOUNT OF OIL IN THE DIFFS

Use a digital scale to measure the exact amount of oil in the diff.

Differential weight with volume compensators = 8.4 grams



### 1.3

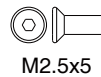
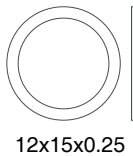

## STEP 1

1.4

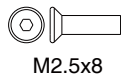
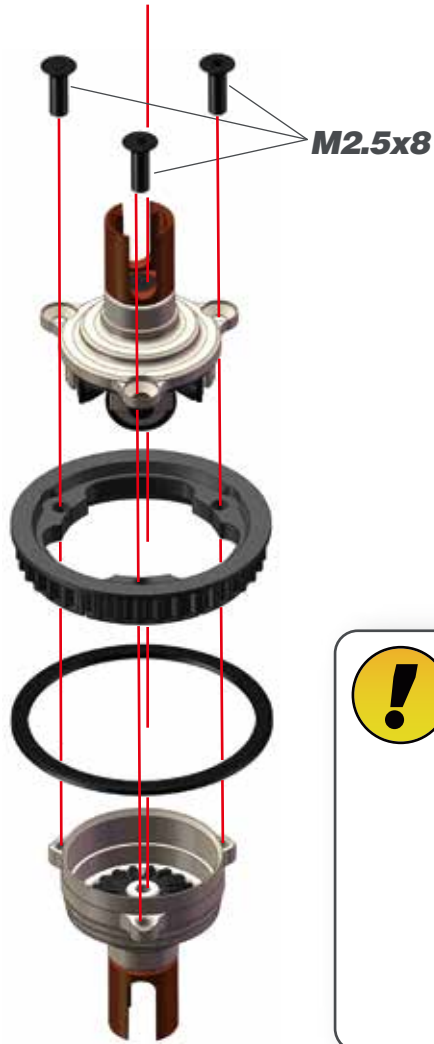

M2.5x8

## STEP 1

## SOLID AXLE BAG

1.4



M3x10

## STEP 2

## DJC BAG

### 2.1

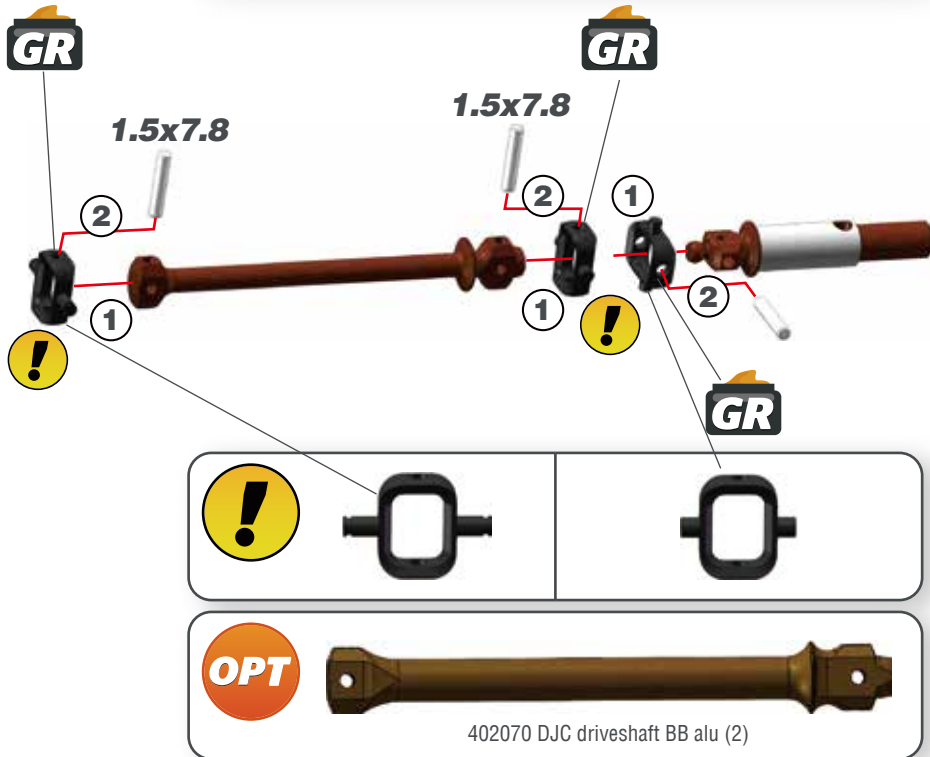

1.5x7.8

### 2.2

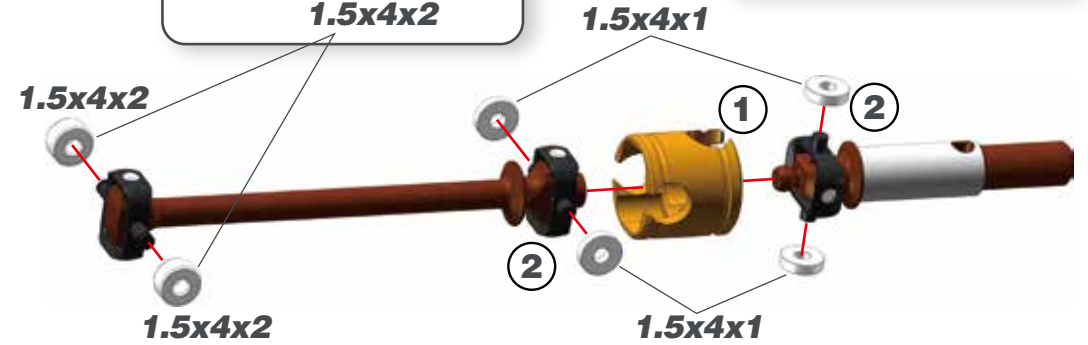
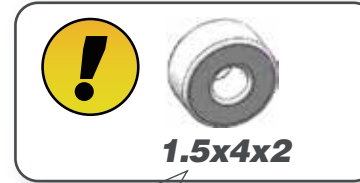

### 2.3

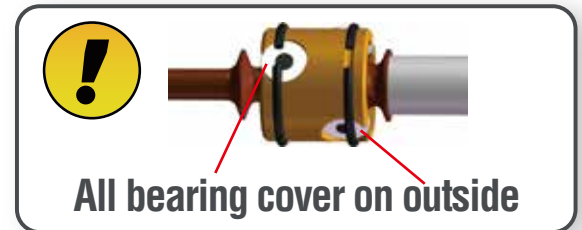

## STEP 2 CVD BAG

### 2.4

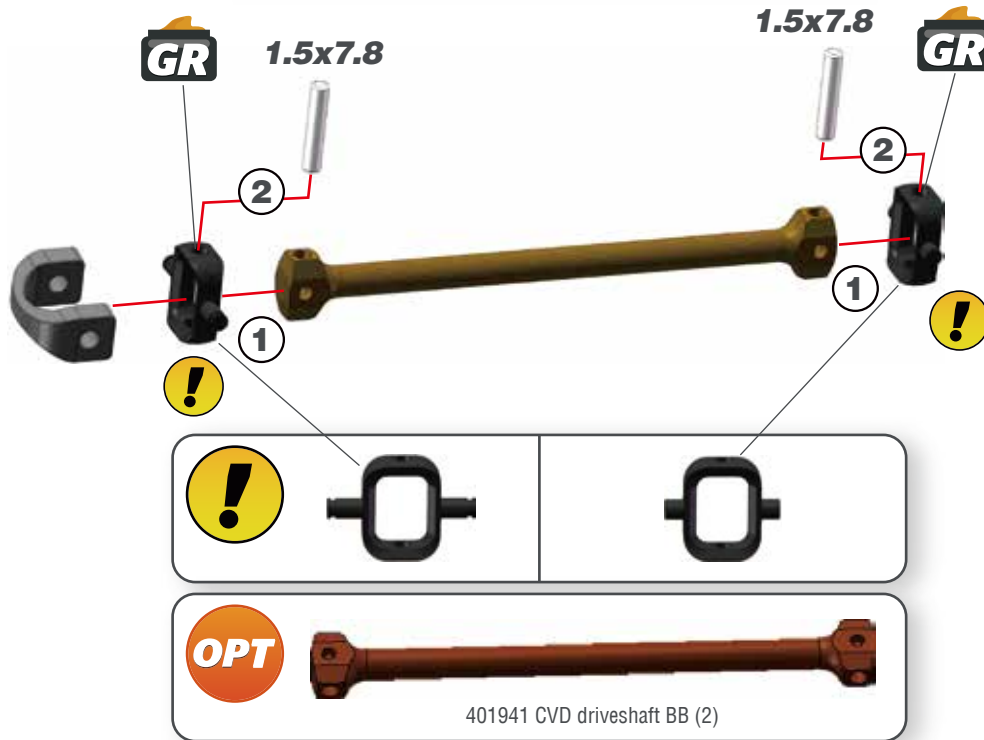

1.5x7.8

### 2.5

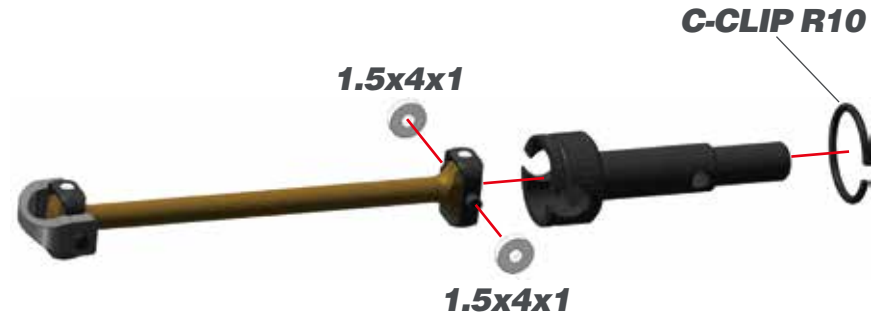

C-CLIP R10

1.5x4x1

## STEP 3 BAG 1

### 3.1 FRONT

4X



3x5x2



PIVOTBALL M3x4

3x5x2

### 3.2 FRONT

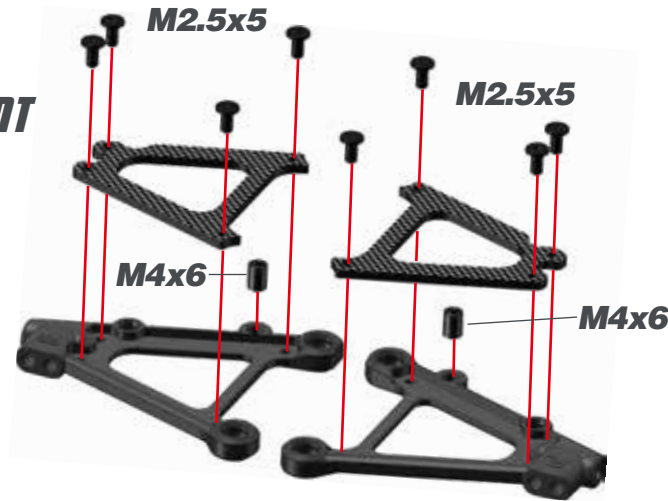

### 3.3 REAR

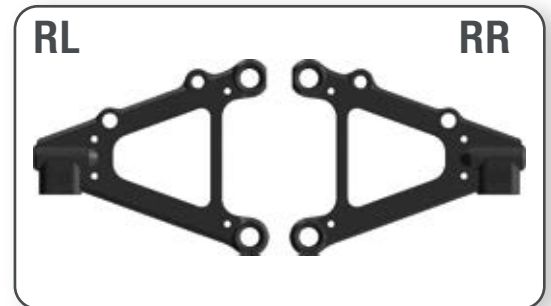
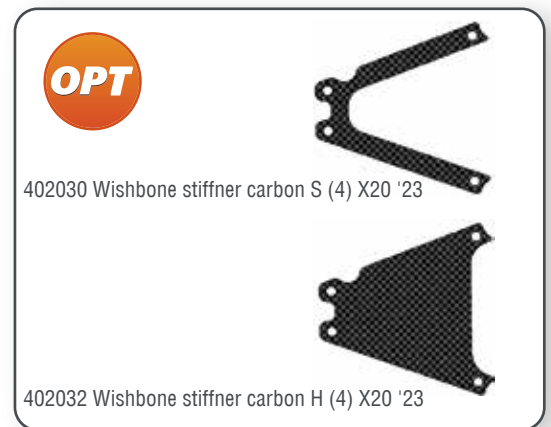
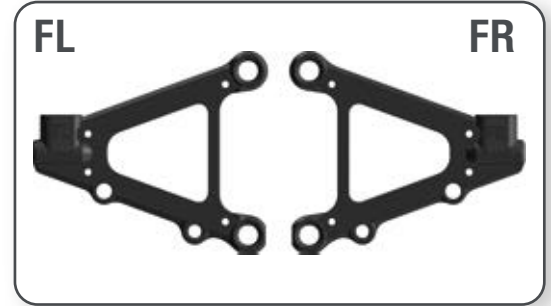
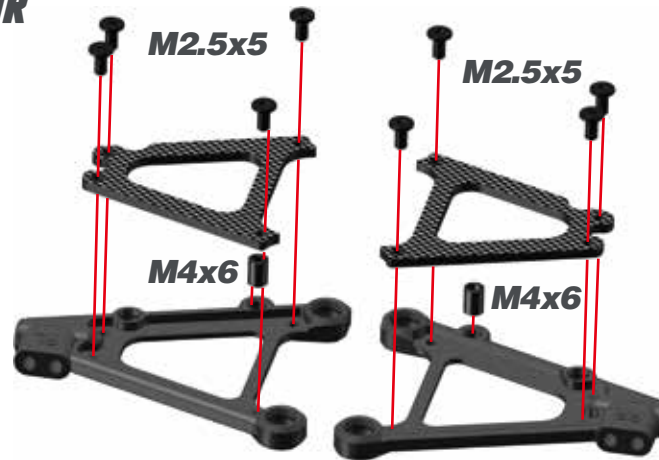

M2.5x5

M4x6







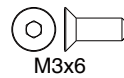
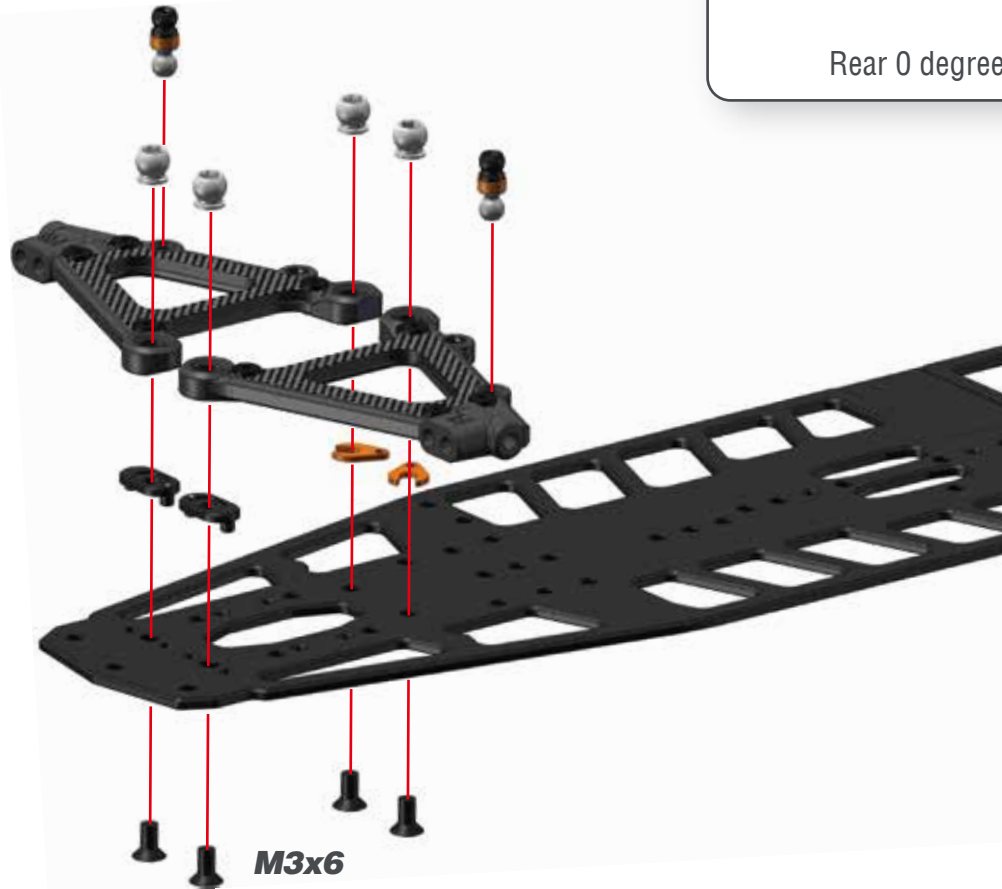

## STEP 4

### 4.1 FRONT



M3x6

	Front 0 degree	Front 1 degree toe out	
			
	Rear 0 degree	Rear 1 degree toe in	

**OPT**  402024 suspension insert lw 0.5deg (4) X20 '23

### 4.2 REAR

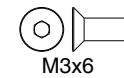
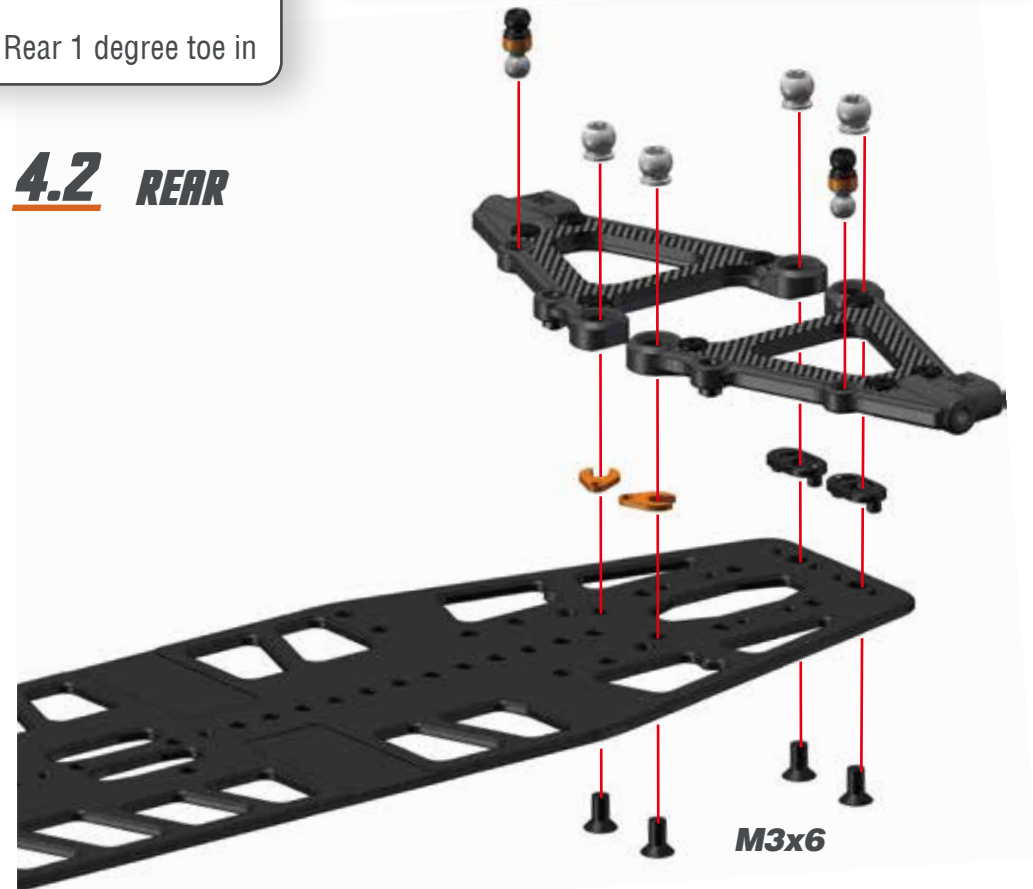

M3x6

## STEP 5

## BAG 2

### 5.1 FRONT

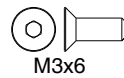
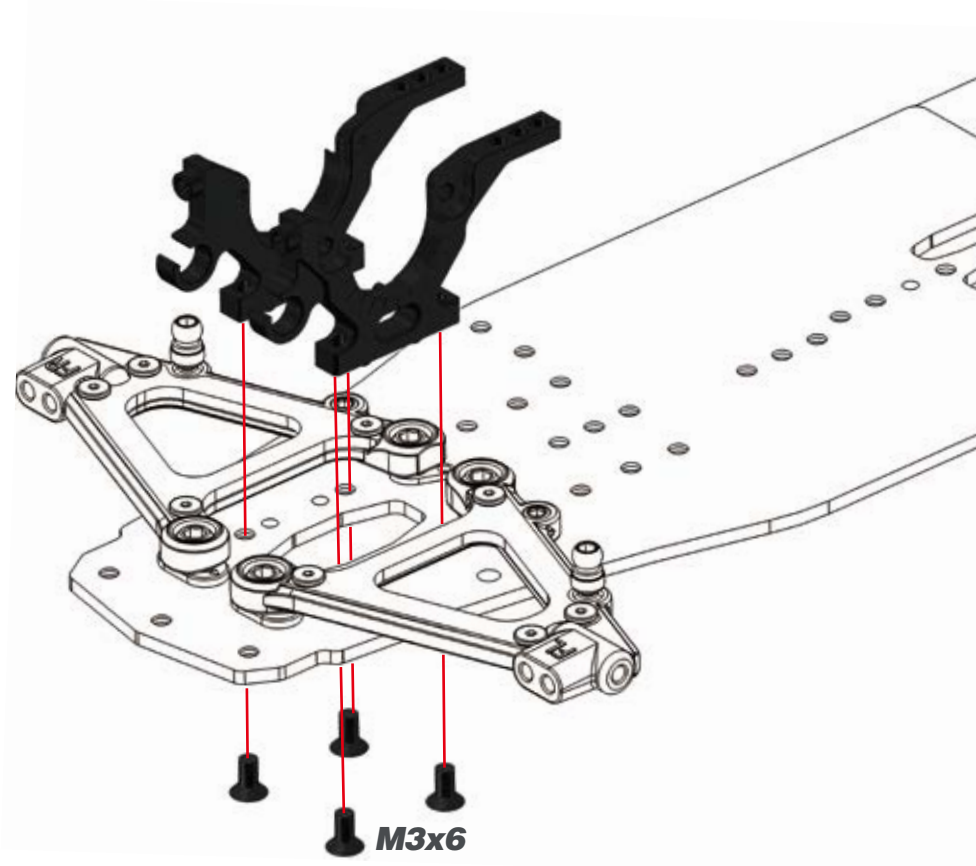

M3x6

### 5.2 REAR

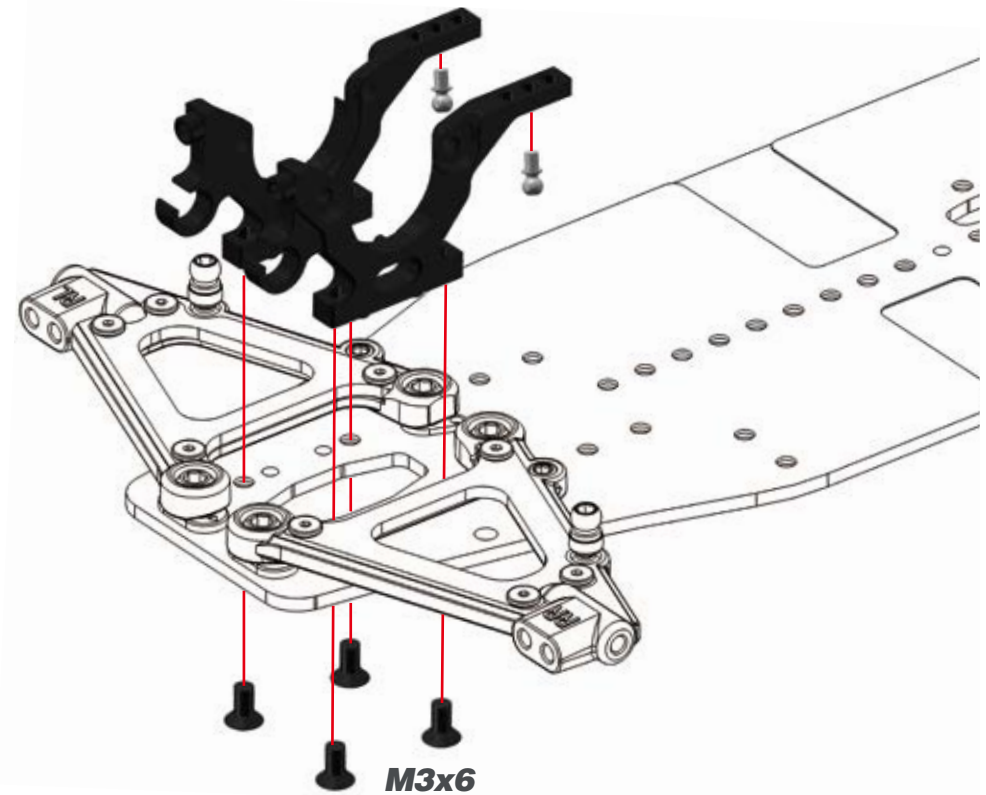

PIVOTBALL M3x4



M3x6

## STEP 6

### 6.1

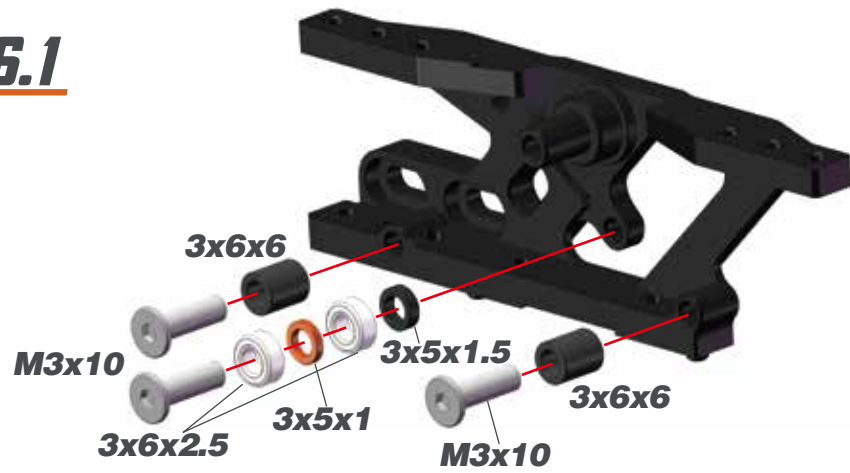

### 6.2

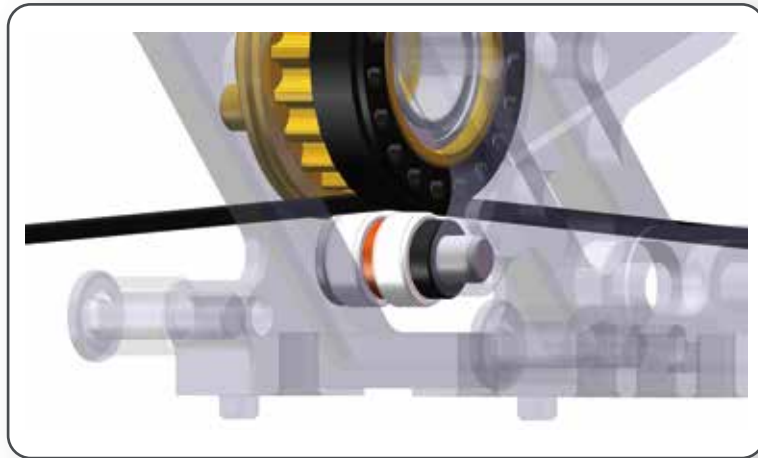
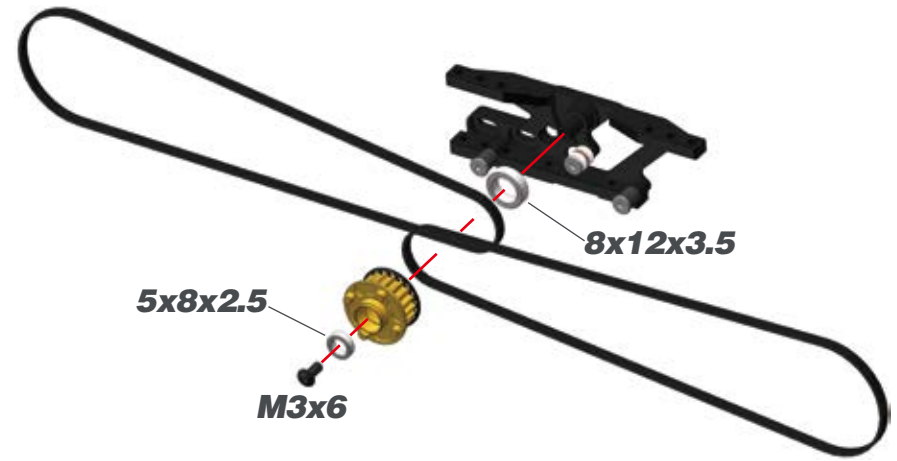

### 6.3

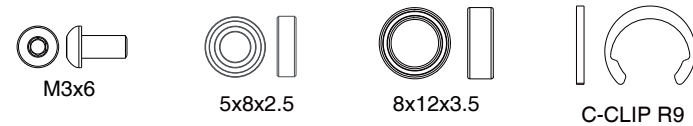
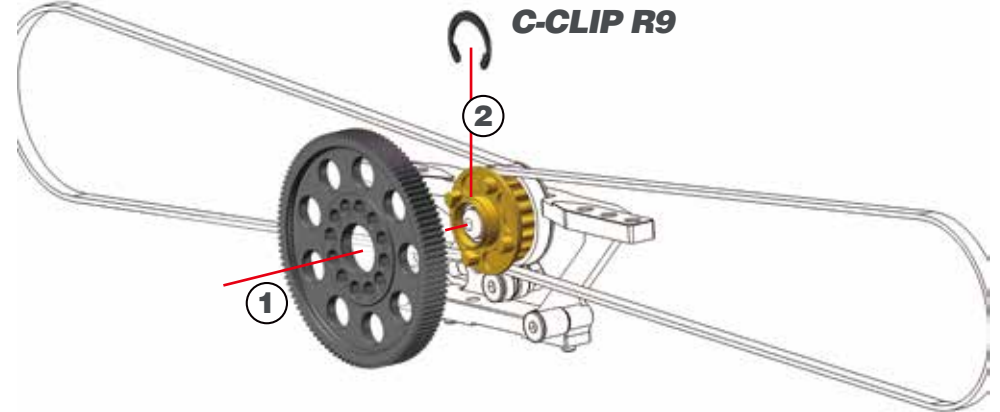

## STEP 6

### 6.4

OPT



401917 Bearing excenter fr/rr (4) alu X20

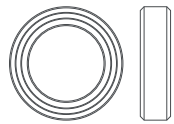
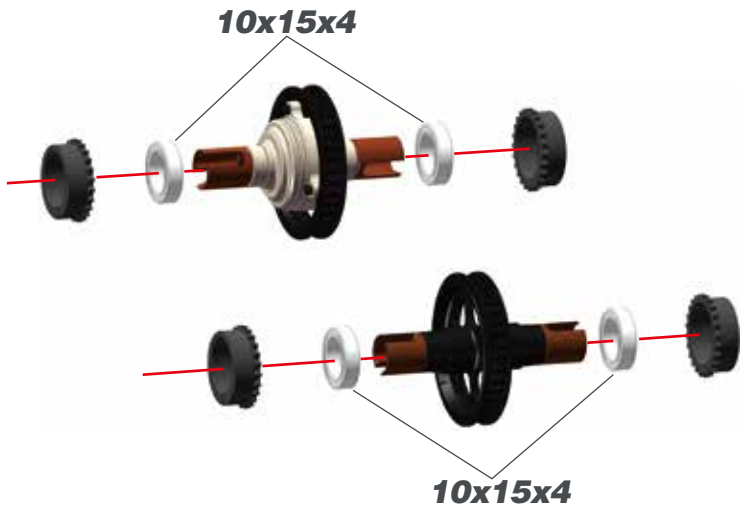

10x15x4

### 6.5

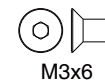
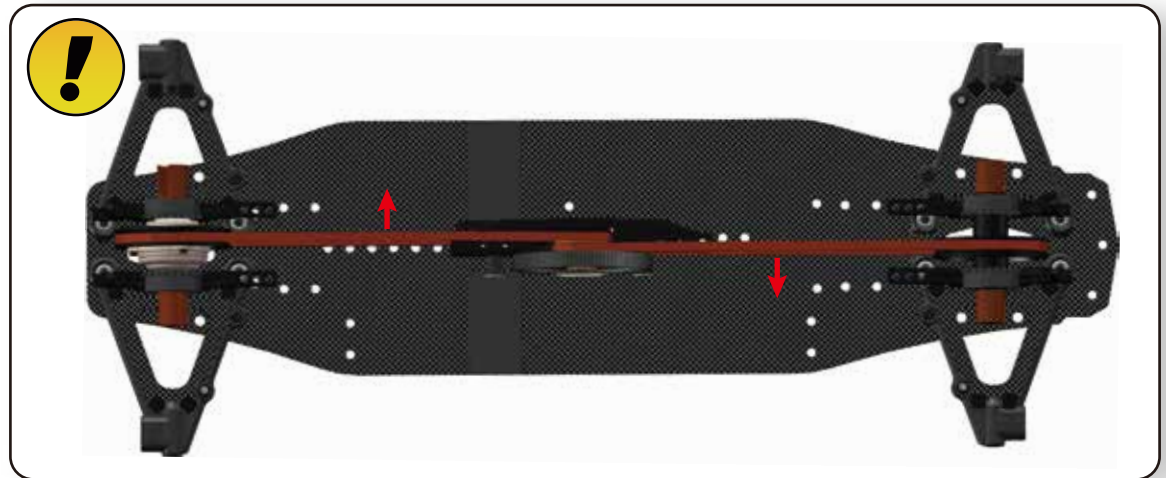
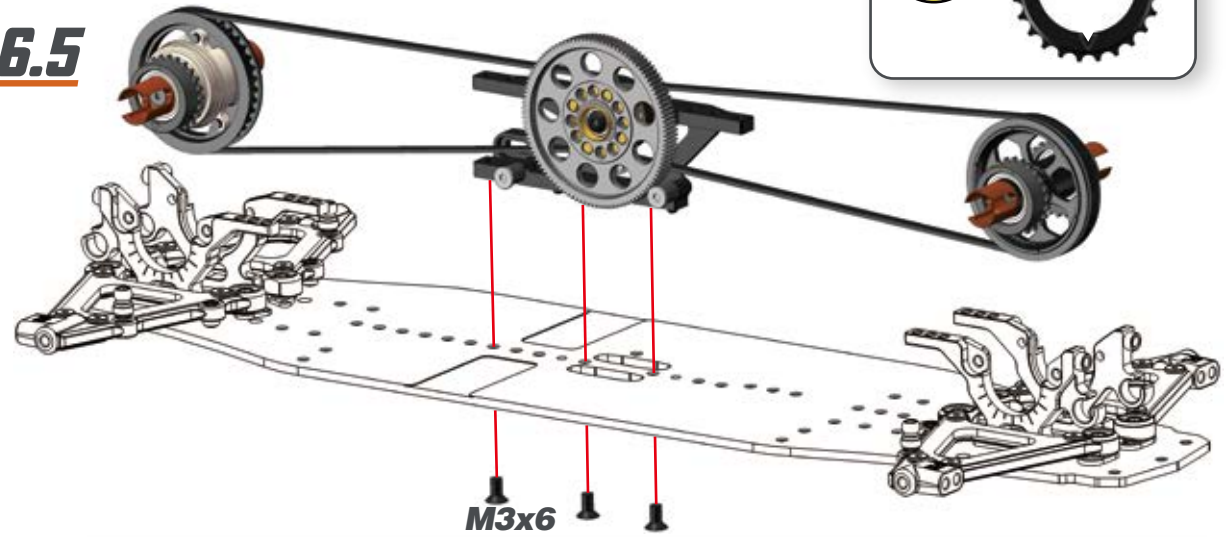

M3x6



## STEP 7 BAG 3

### 7.1 FRONT

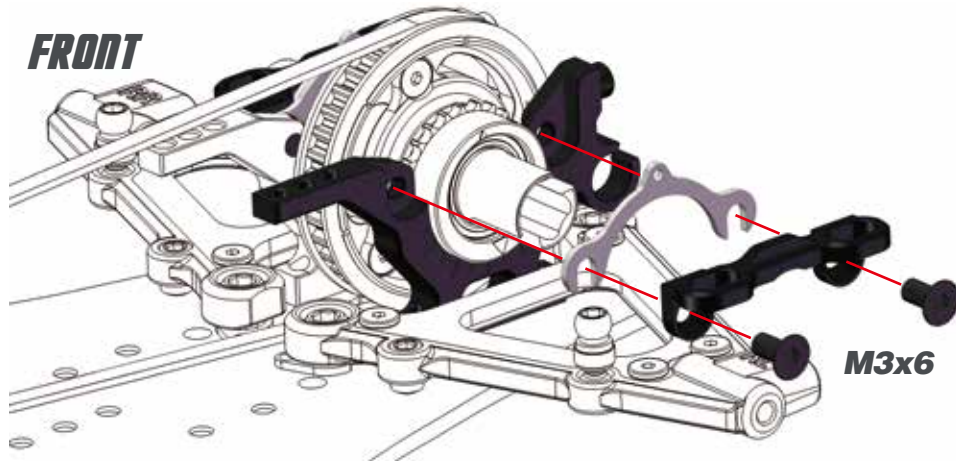

### 7.2

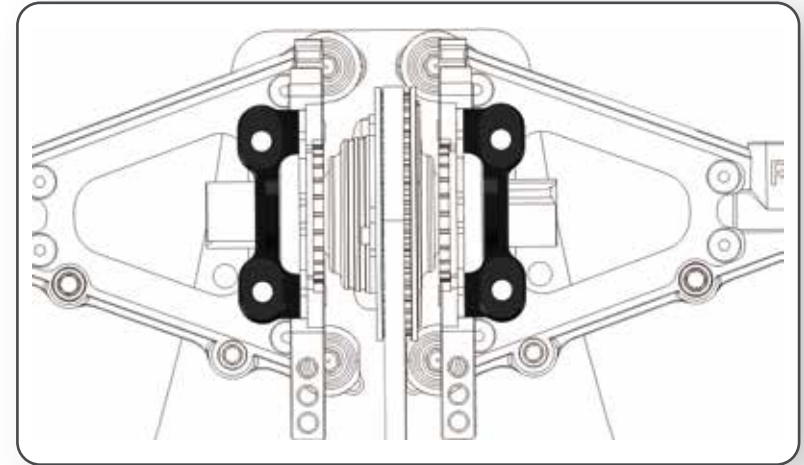
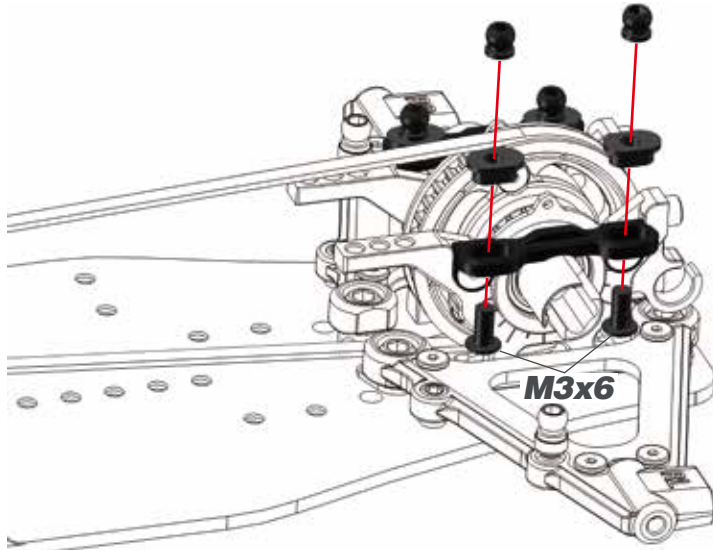

Lower arm 0 toe in	Rear	Lower arm 1 toe in



## STEP 7

### 7.3

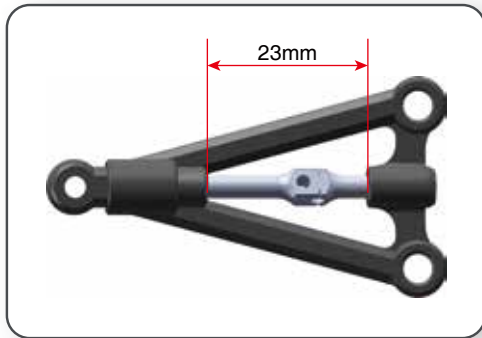

2X

### 7.4

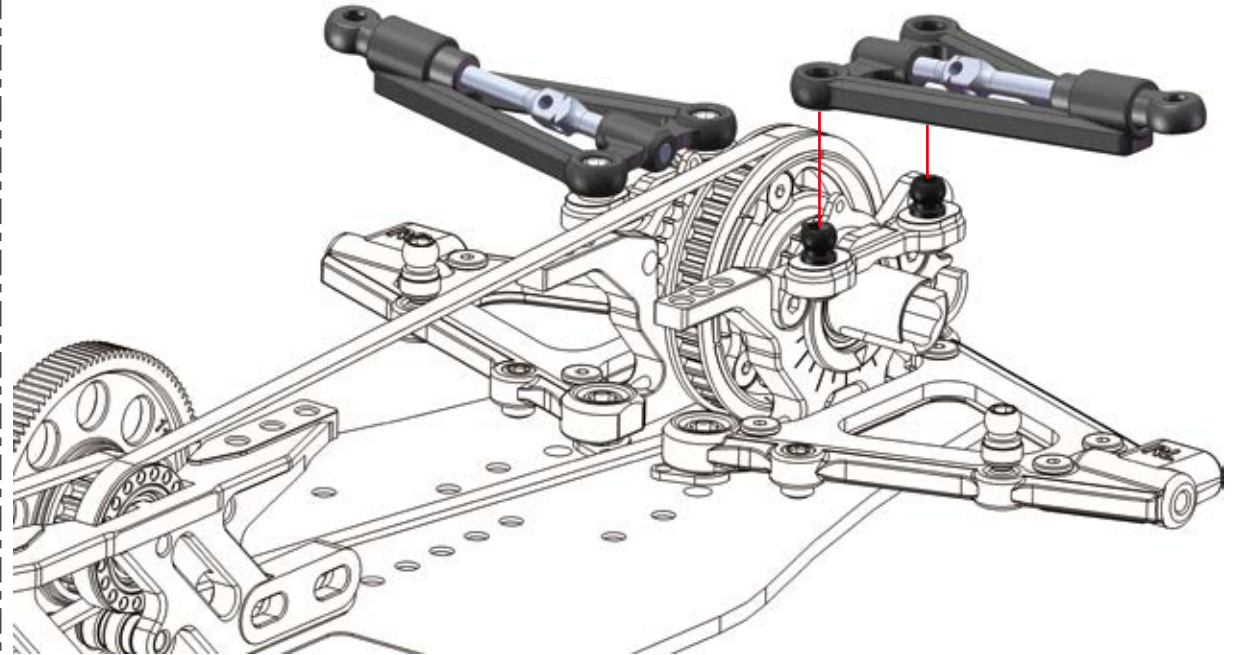

## STEP 7

R=L

7.5

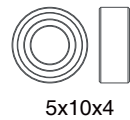
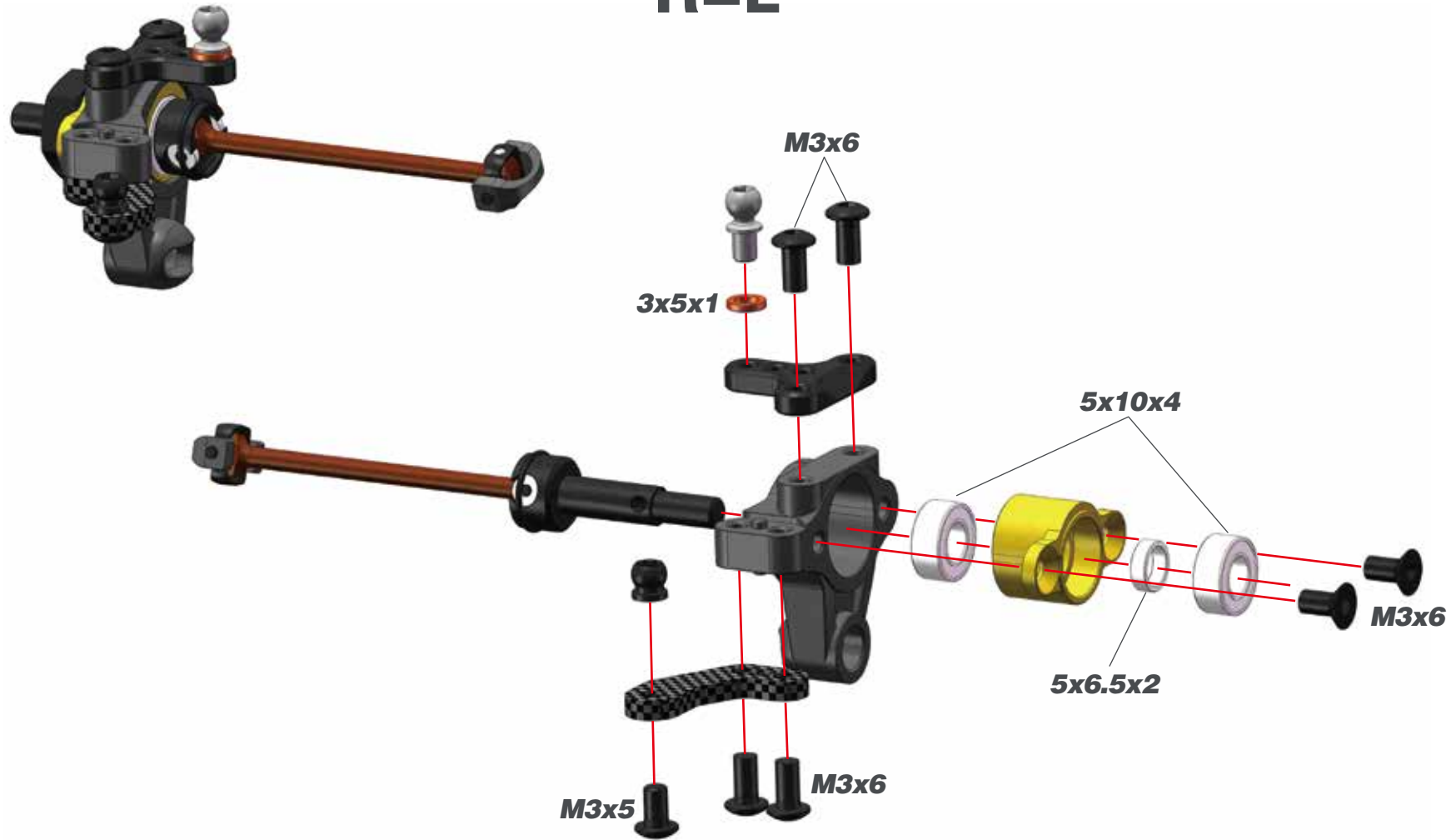

## STEP 7

### 7.6

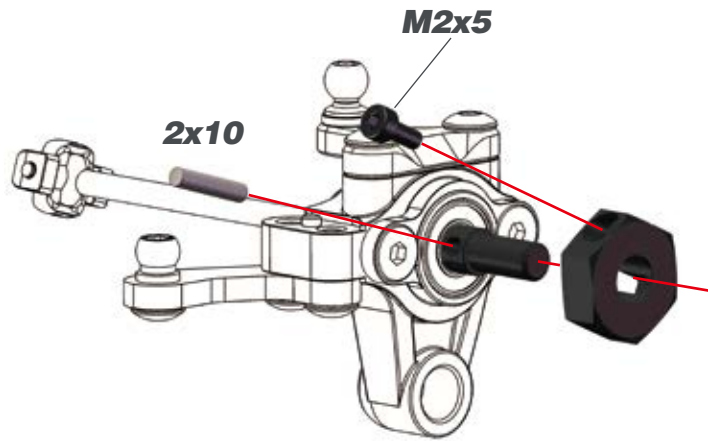

### 7.7

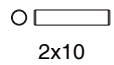
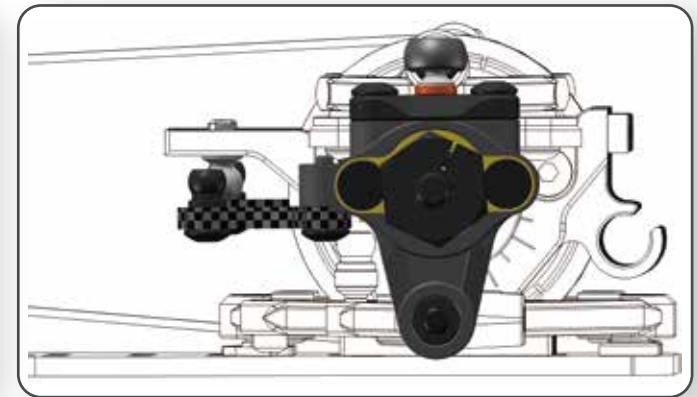
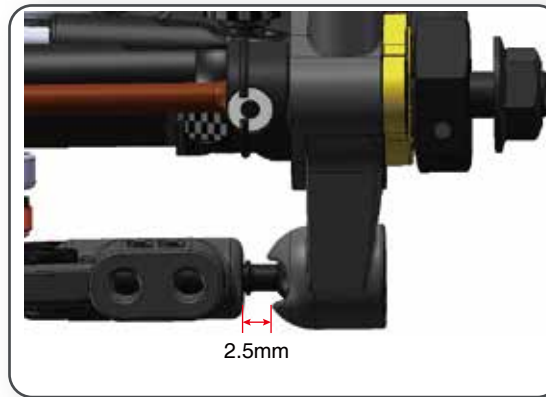
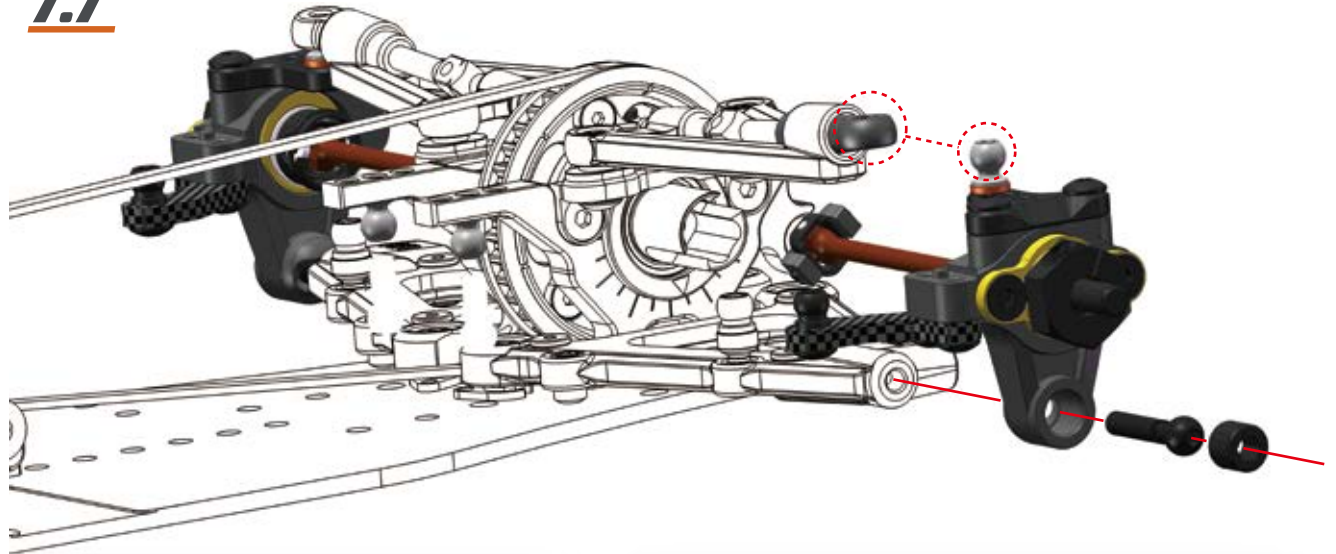



## STEP 7

### 7.8

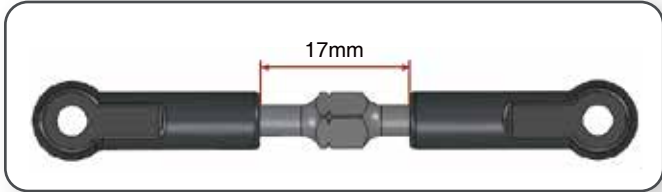
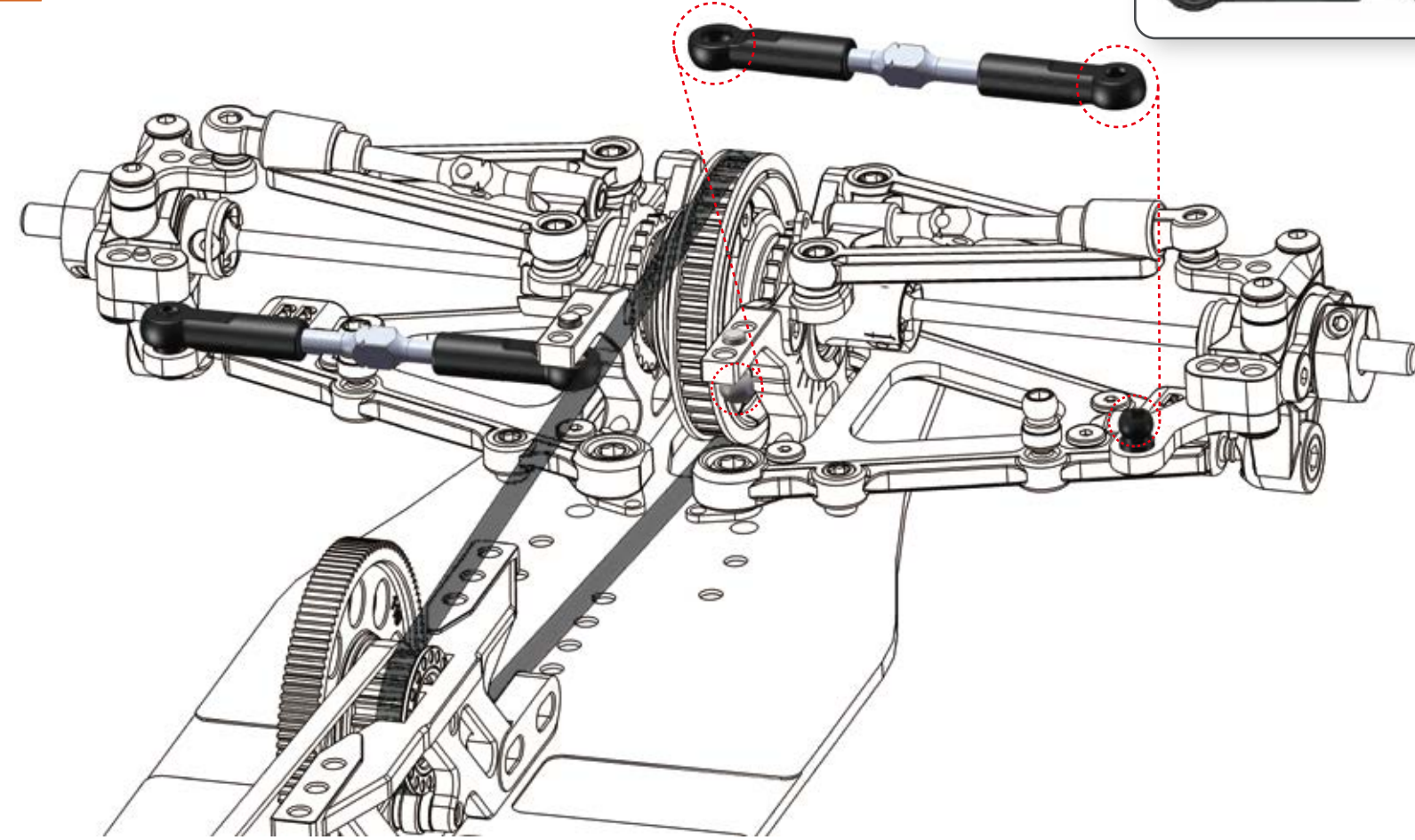

## STEP 8 BAG 4

### 8.1 REAR

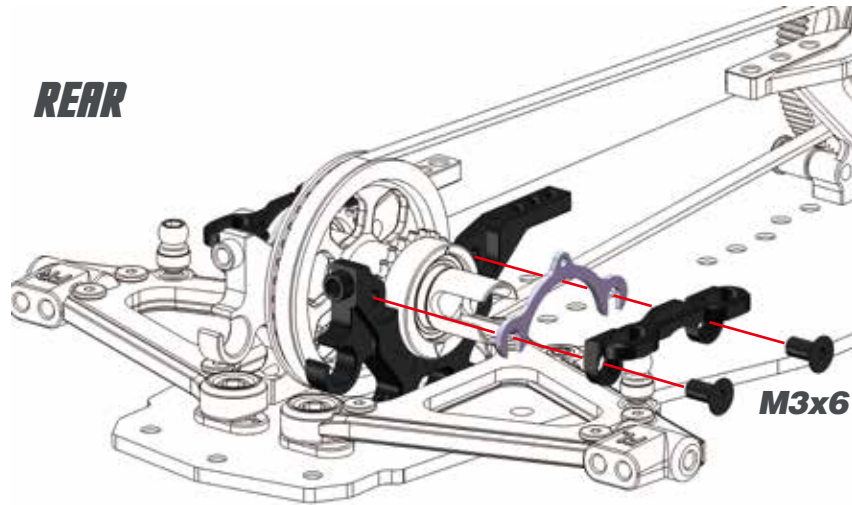

### 8.2

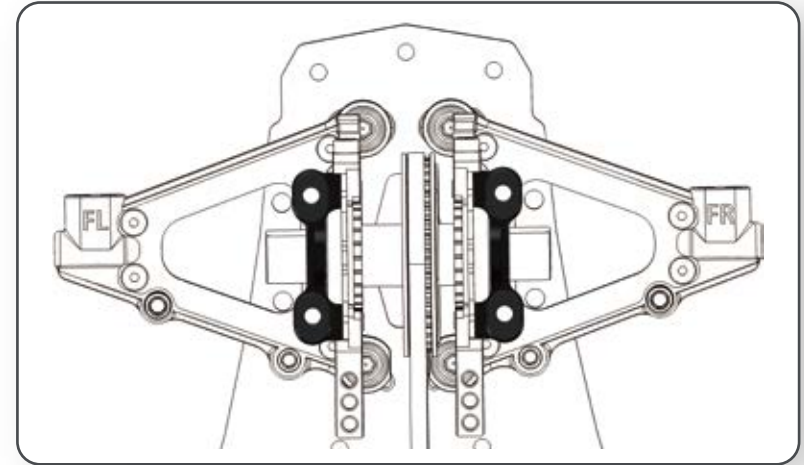
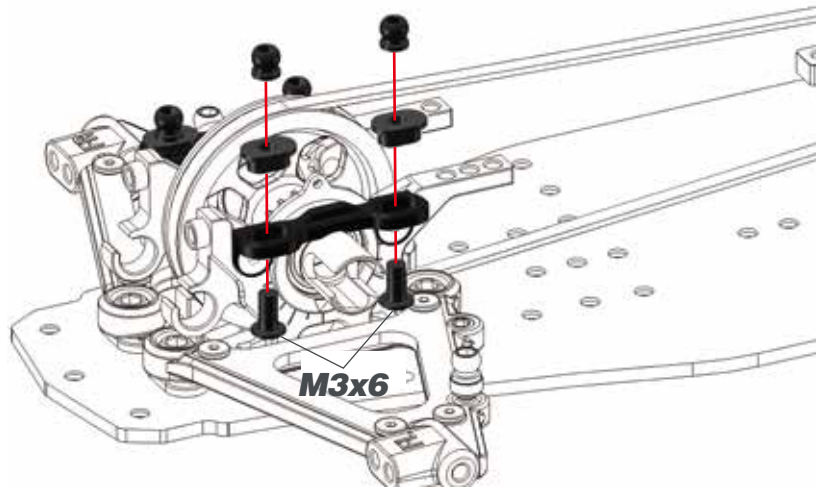

Lower arm 0 toe, caster angle:	Front	Lower arm 1 toe, caster angle:
	3°	1°
✓	4°	2°
	5°	3°
	6°	4°
	7°	5°
	8°	6°

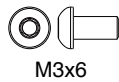

## STEP 8

### 8.3

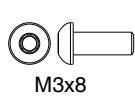
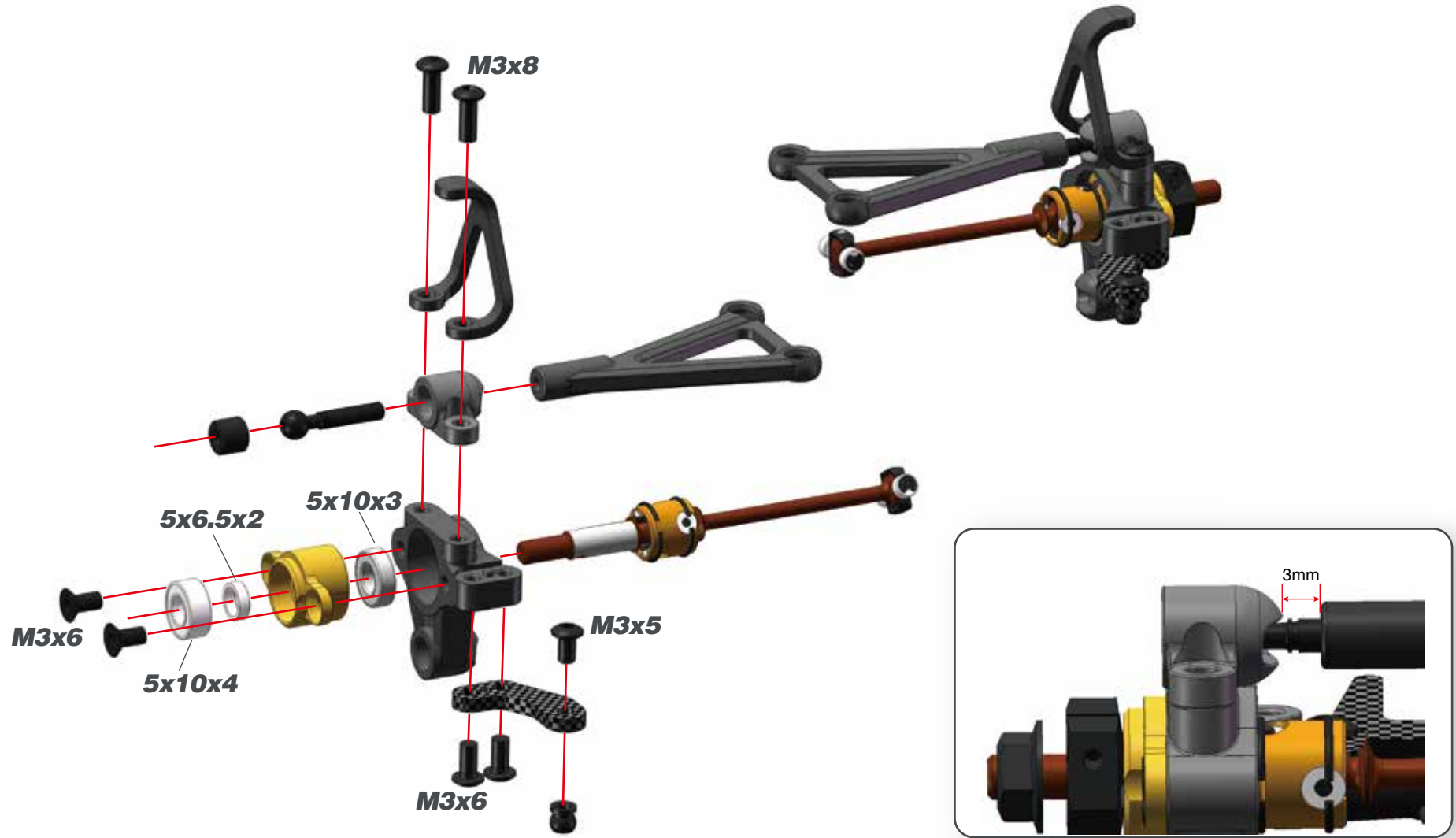

M3x8



5x10x4



5x10x3



5x6.5x2

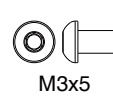

M3x5

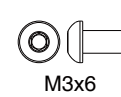

M3x6

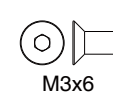

M3x6

## STEP 8

### 8.4

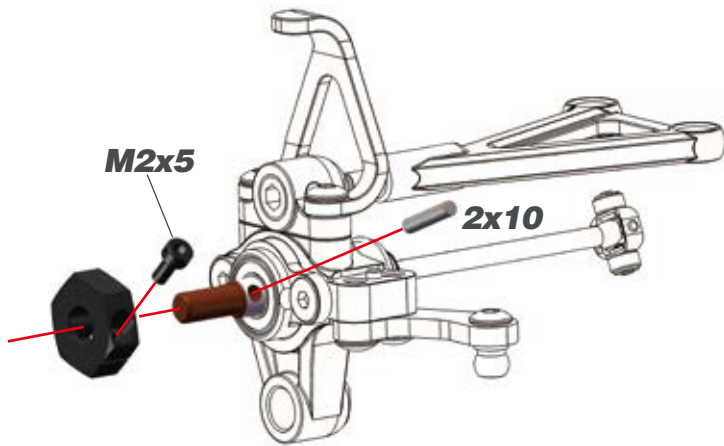

### 8.5

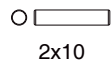
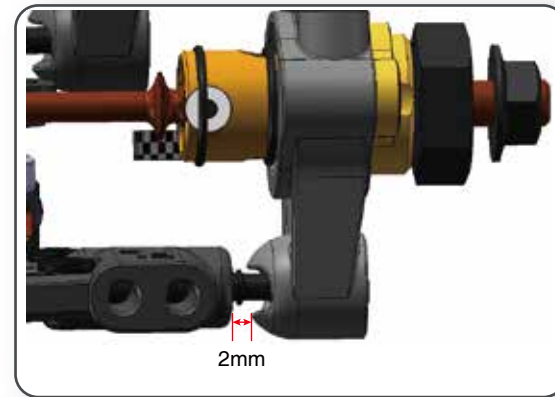
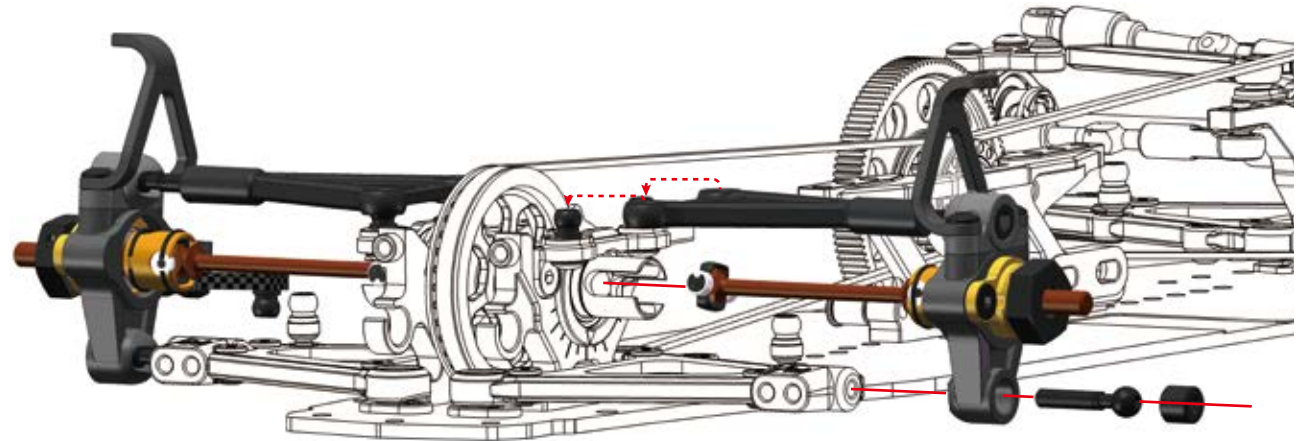

2x10



M2x5



## STEP 9

## BAG 5

### 9.1 FRONT & REAR

FRONT 1.4MM

REAR 1.2MM

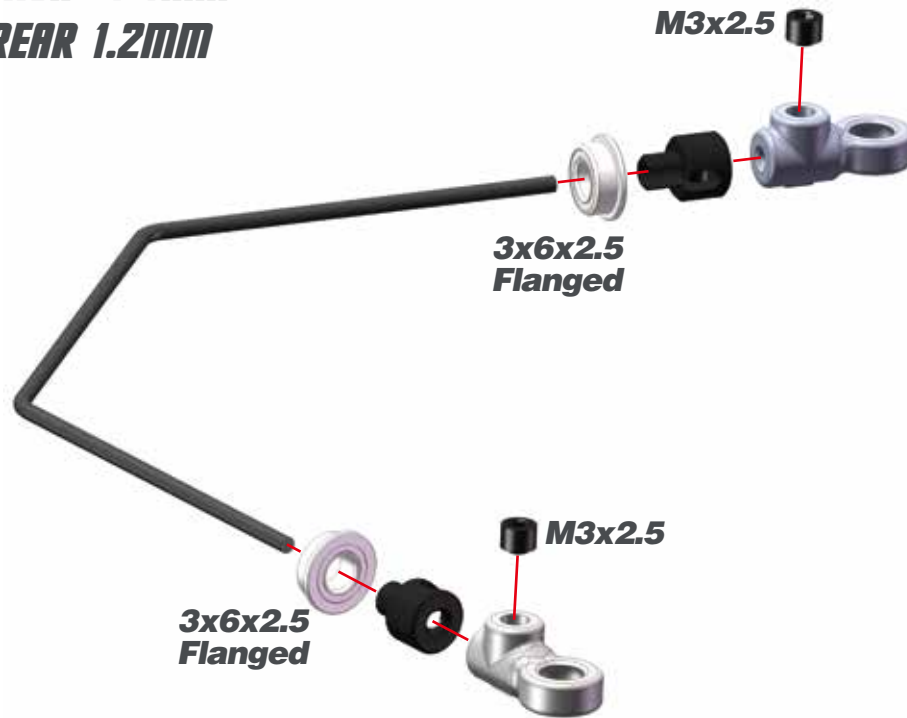

### 9.2 REAR

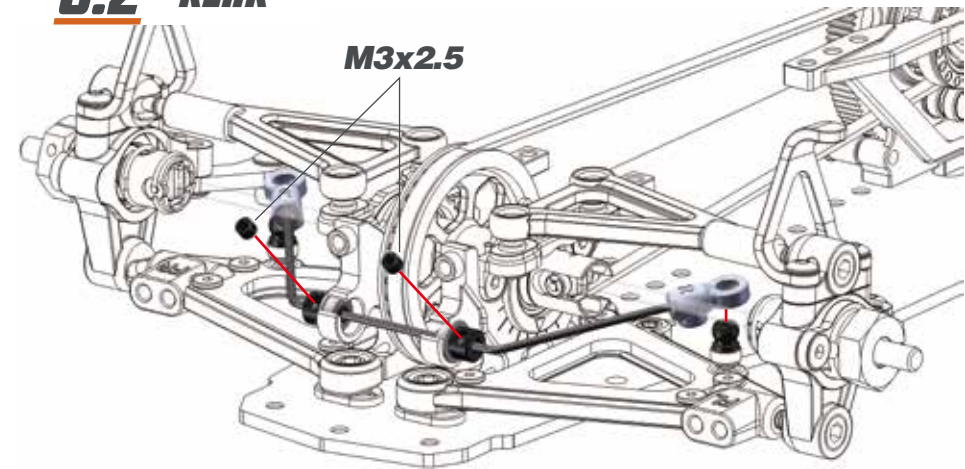

### 9.3 FRONT

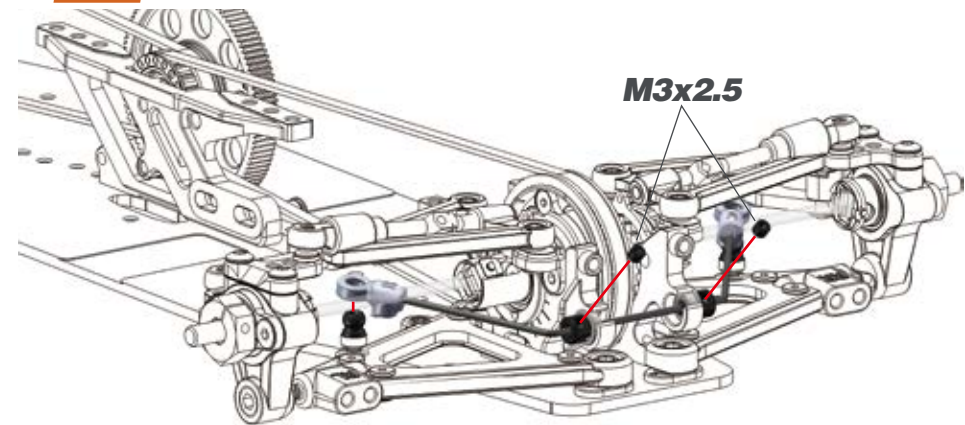

## STEP 10

### 10.1

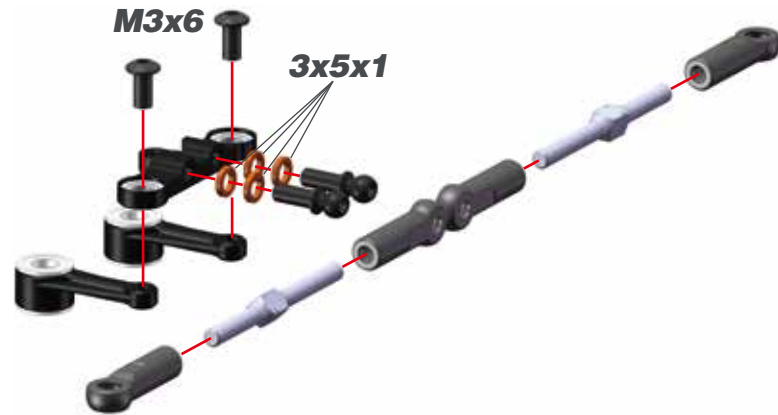
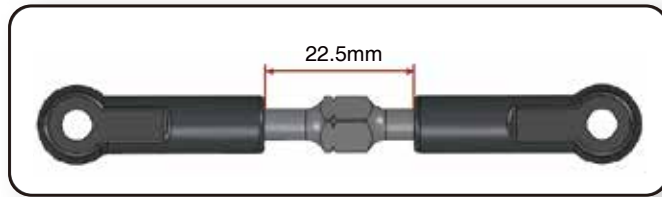

### 10.2

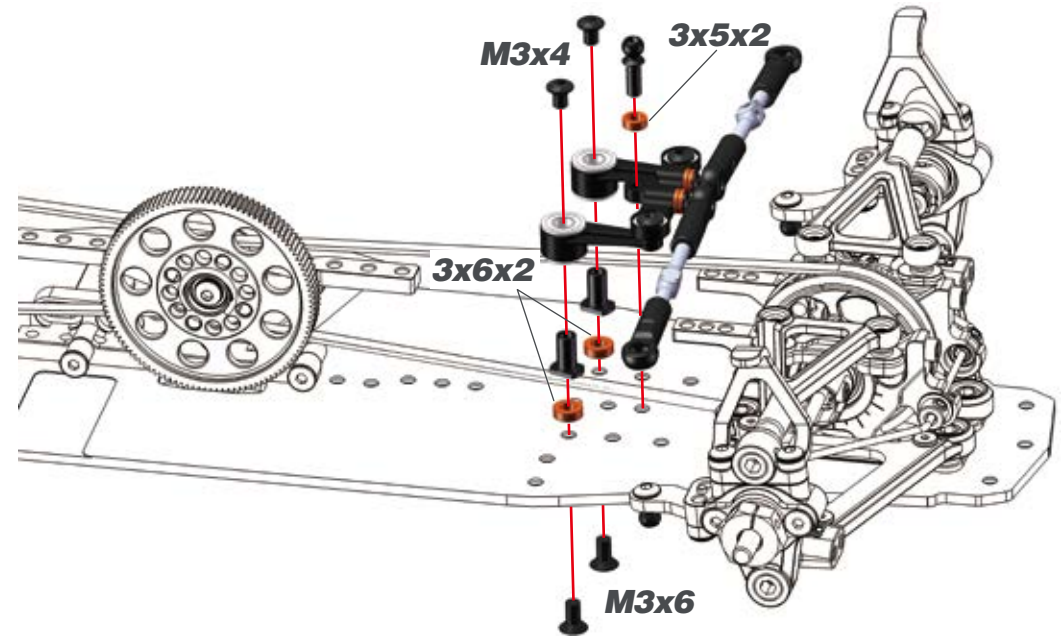

## STEP 10

### 10.3

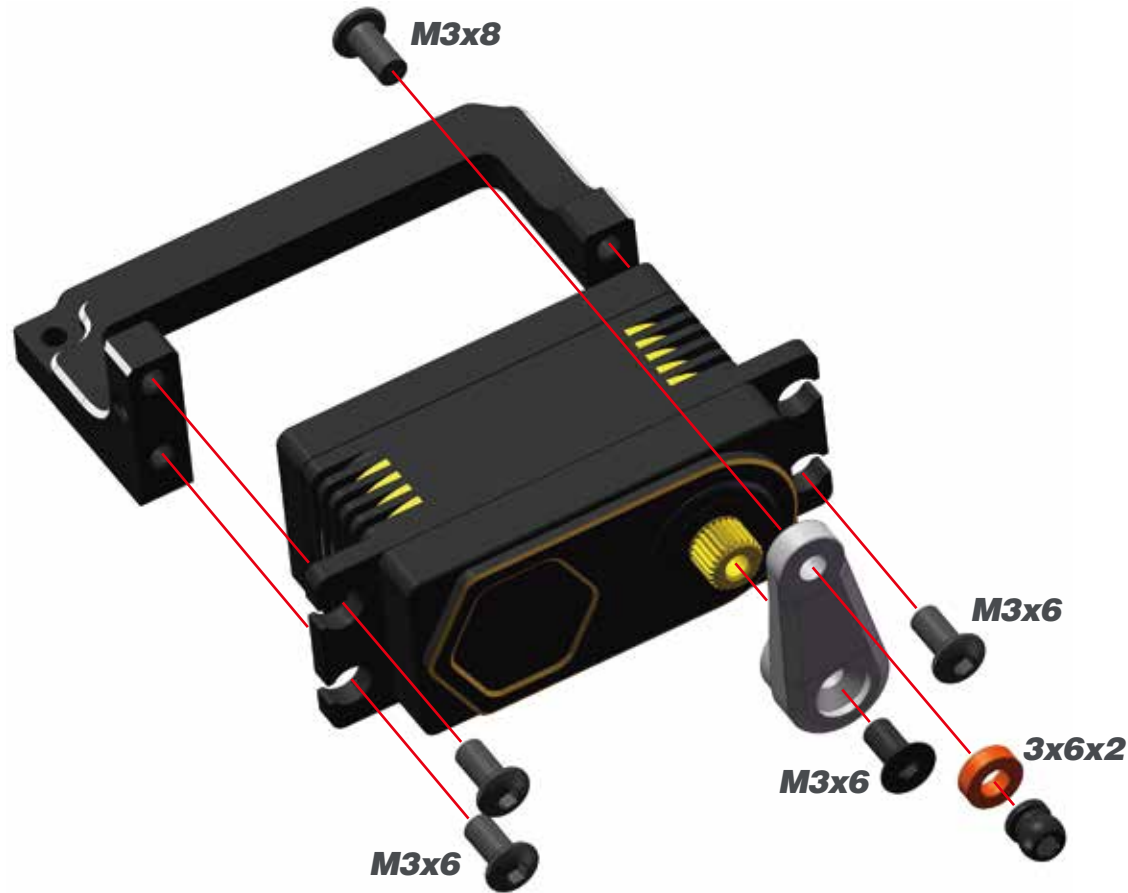

**OPT**



- 600290 Servo lever steering 23T alu
- 600291 Servo lever steering 24T alu
- 600292 Servo lever steering 25T alu

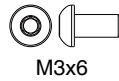
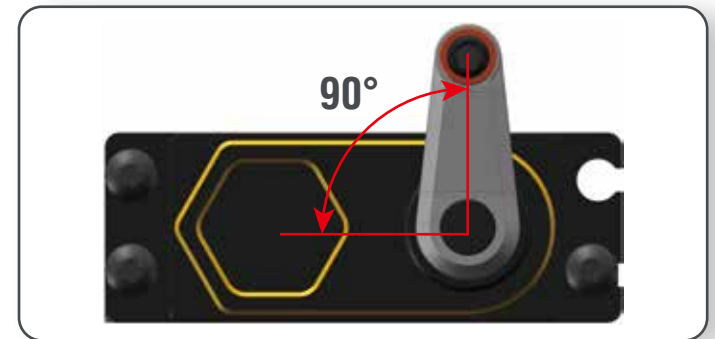

## STEP 10

### 10.4

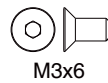
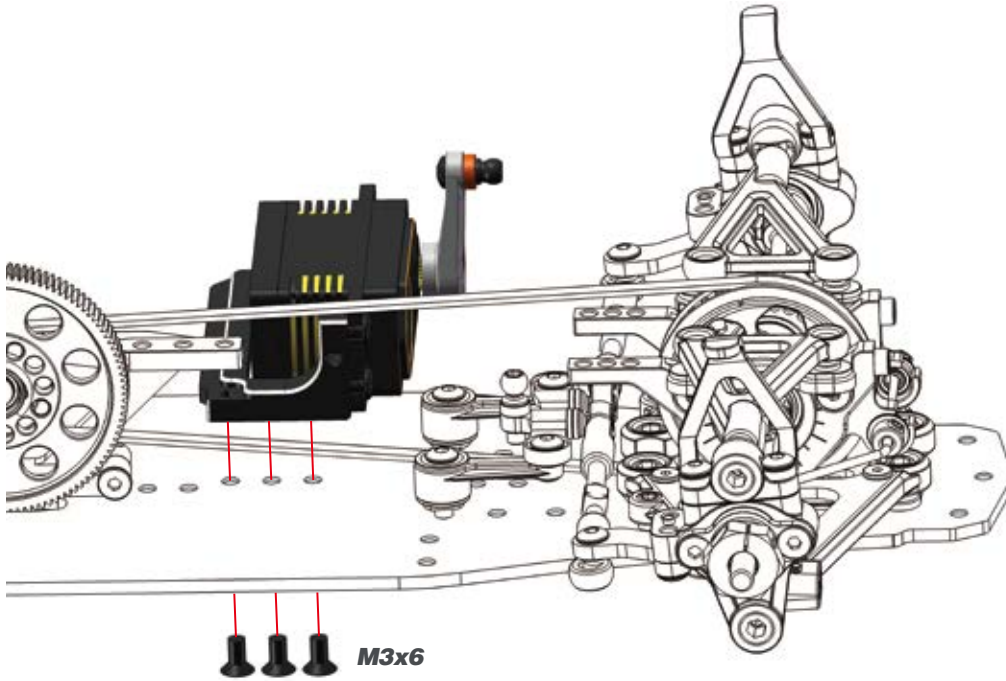

### 10.5

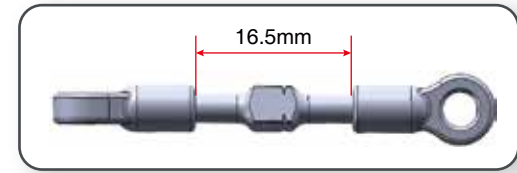

### 10.6

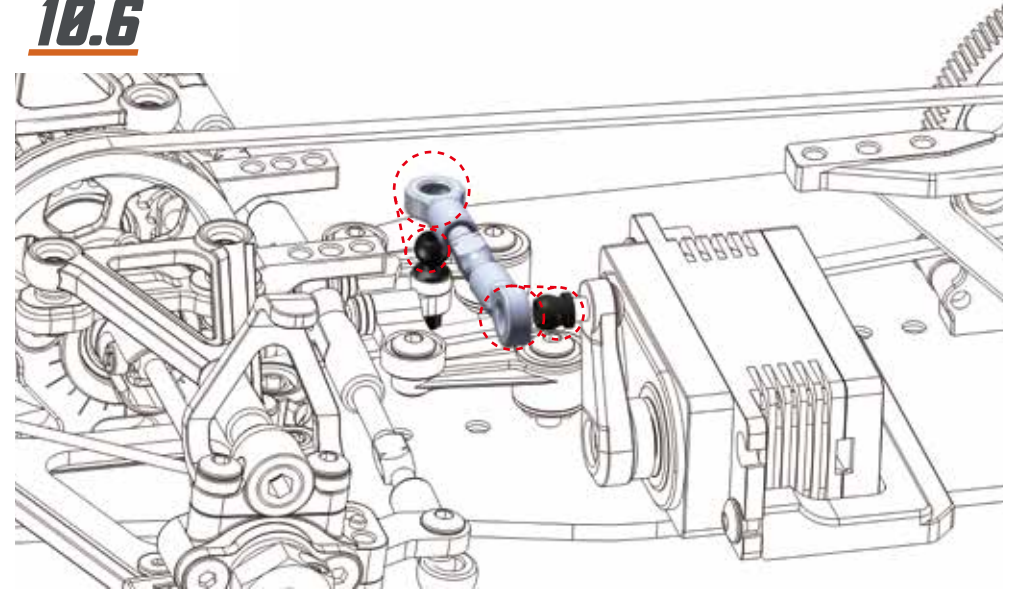



## STEP 11

BAG 6

### 11.1

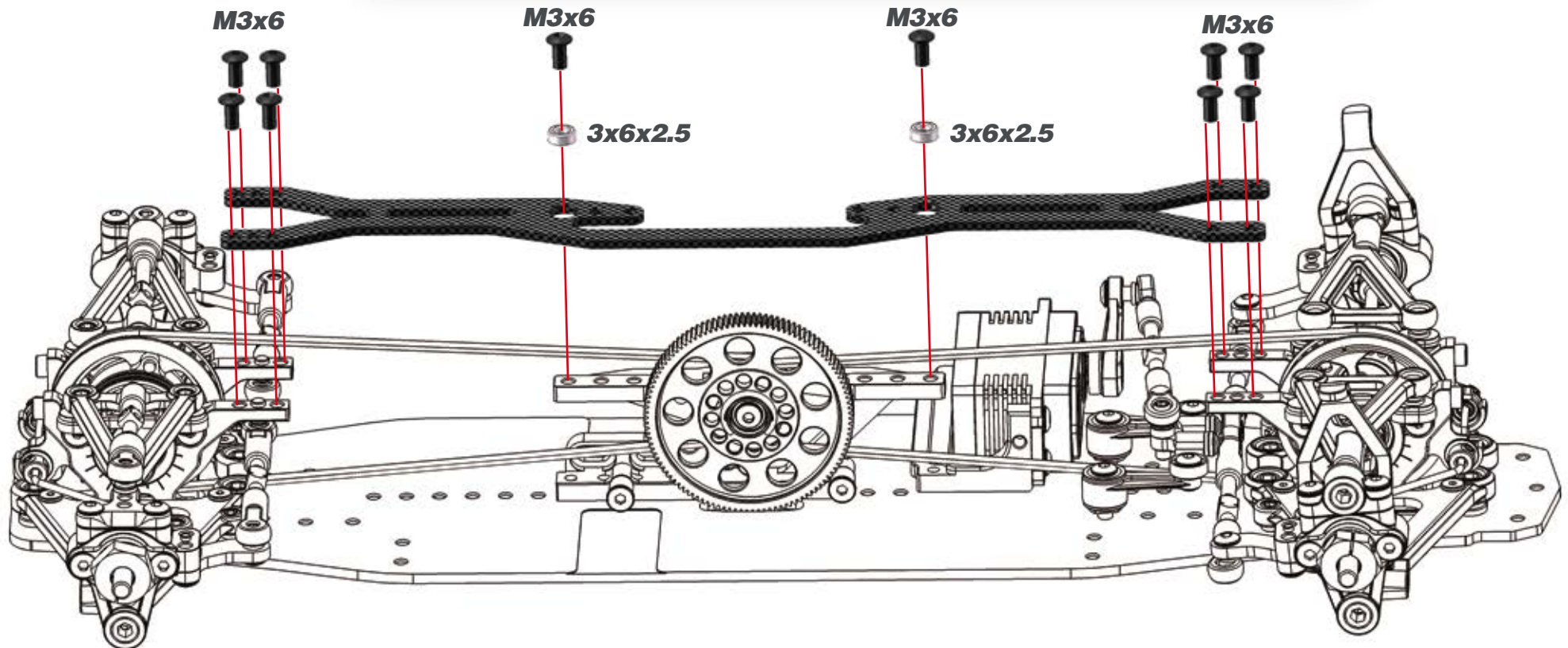

## STEP 11

11.2

R=L

M3x16 Flanged

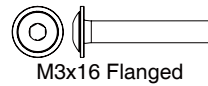
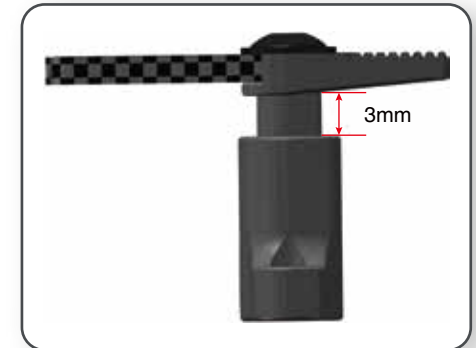

## STEP 11

### 11.3

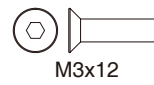
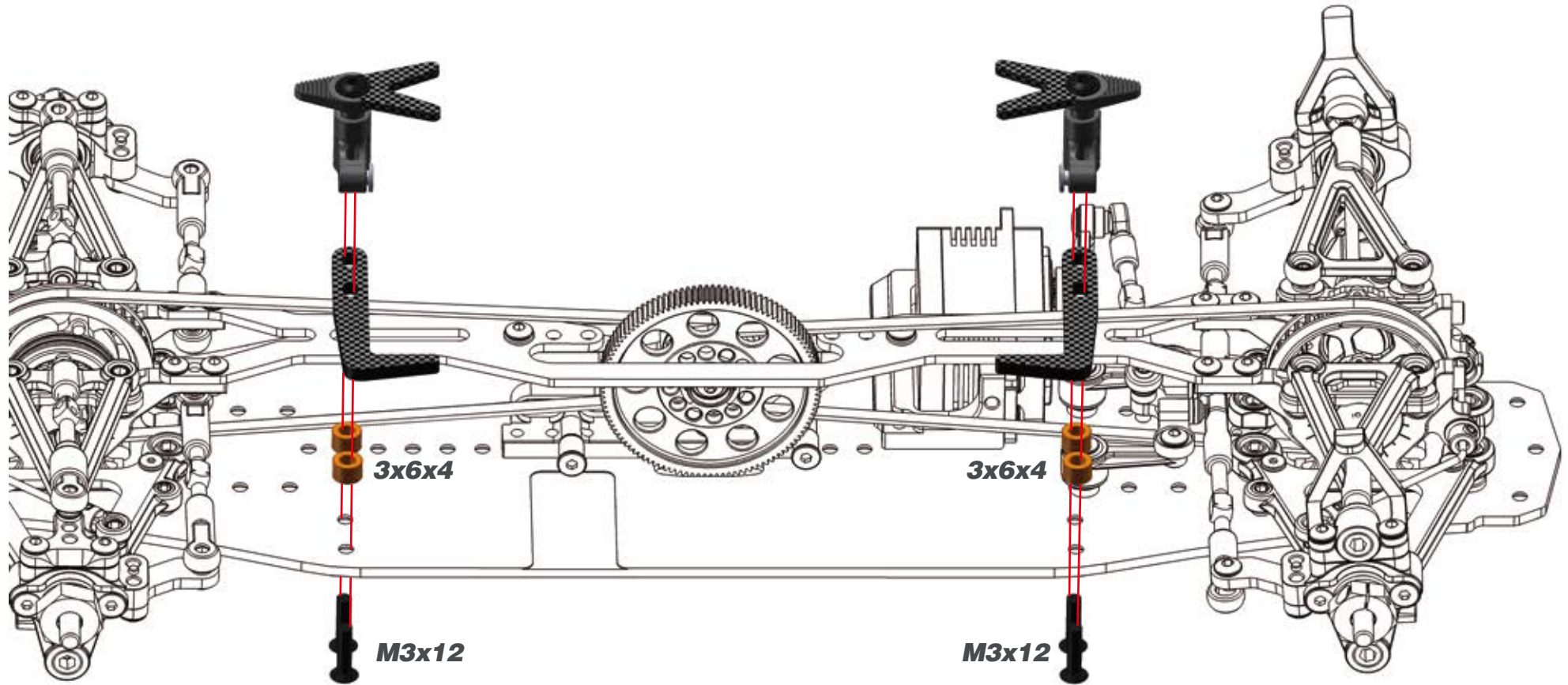

## STEP 12 SHOCK BAG

### 12.1



### 12.2



### 12.3

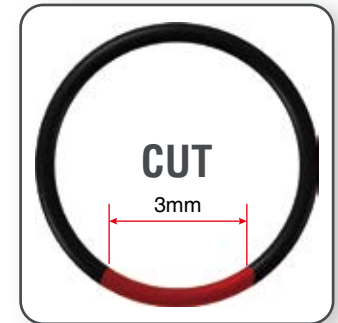



## STEP 12

### 12.4



### 12.5



### 12.6



**OPT**  160156 Shock spring support low onroad alu (4)

## STEP 13 BAG 7

### 13.1 FRONT

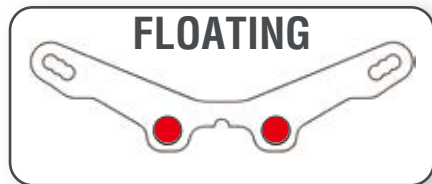
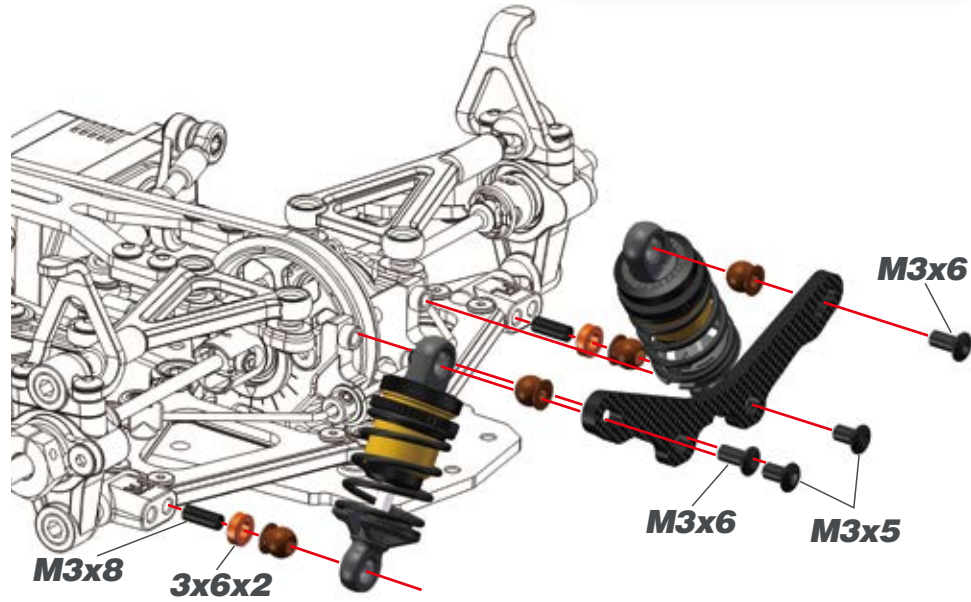
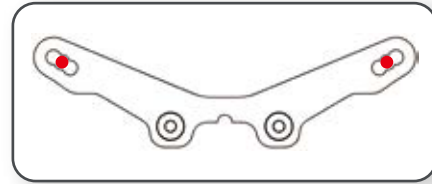

FLOATING

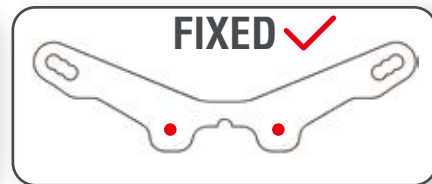

FIXED ✓

### 13.2 REAR

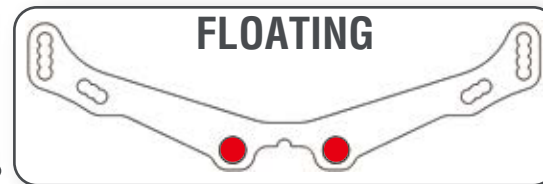
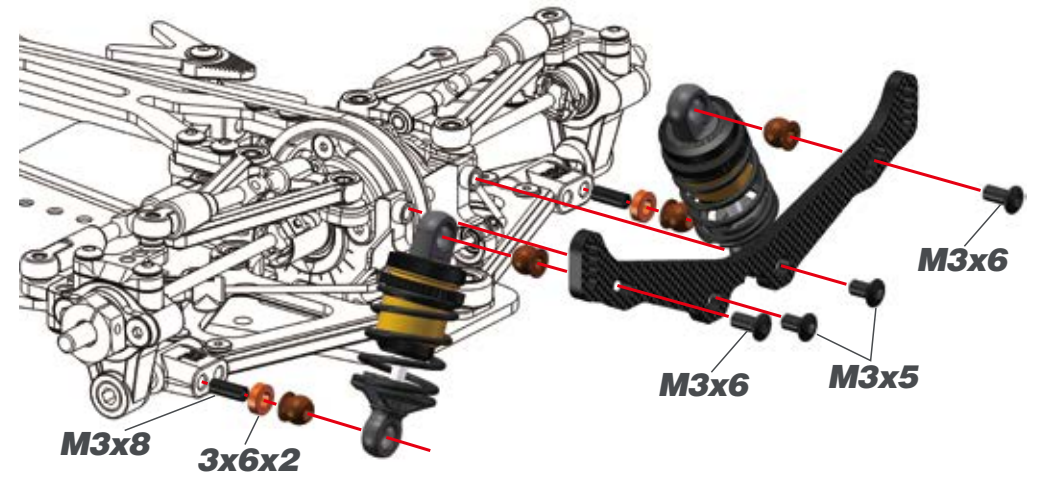
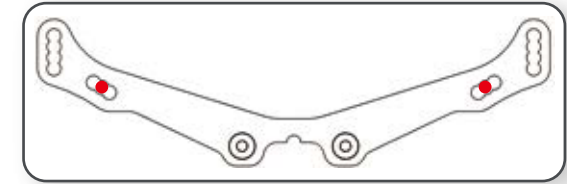

FLOATING

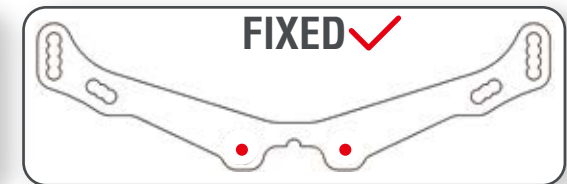

FIXED ✓



3x6x2



M3x8



M3x5



M3x6

## STEP 14

### 14.1

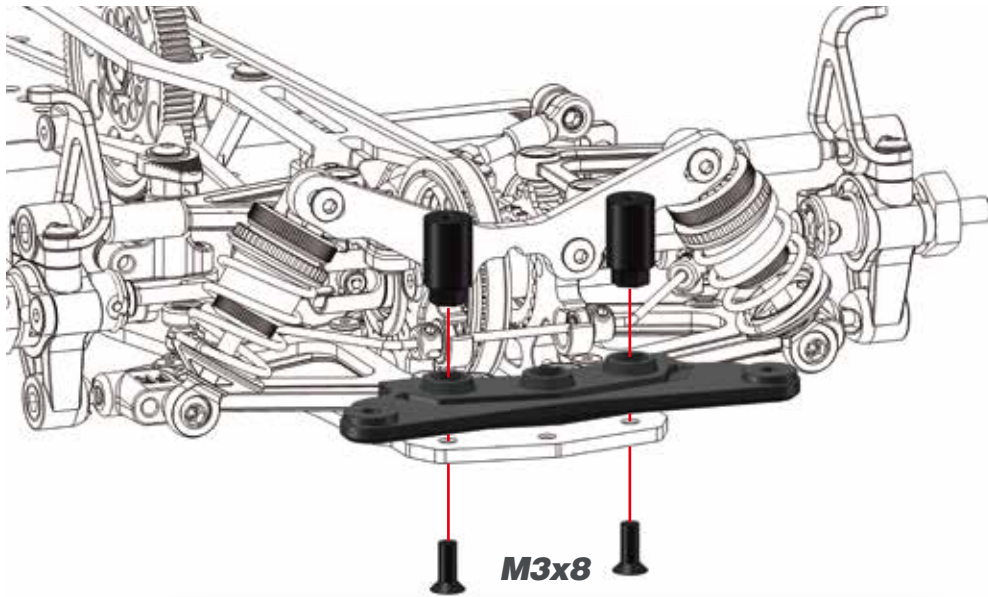

**OPT**



401954 Bumper top carbon X20 '21

**OPT**



401602 Body-height fine-tuner alu (4)



### 14.2

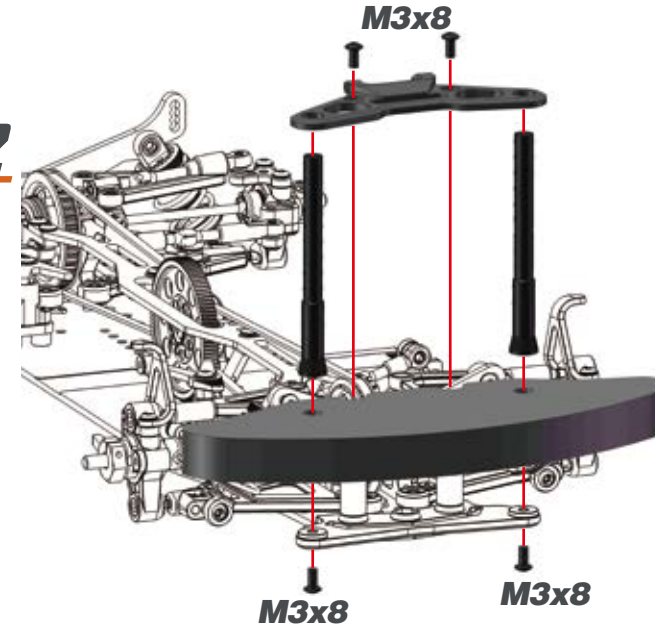

### 14.3

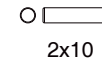
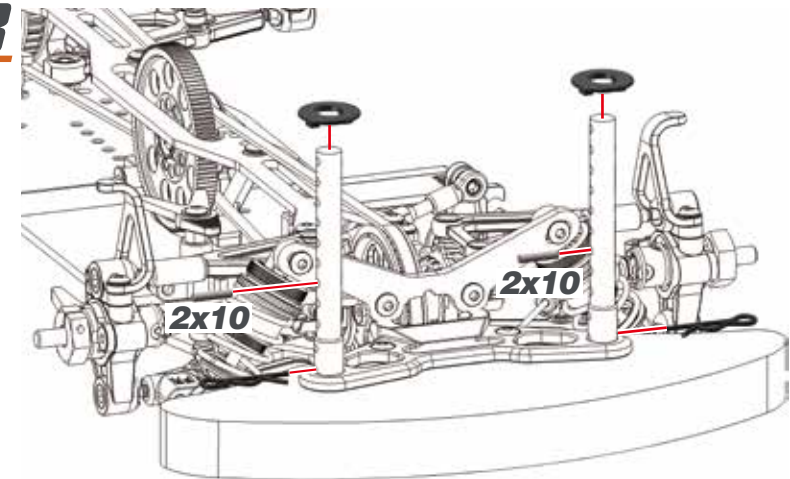

## STEP 14

### 14.4

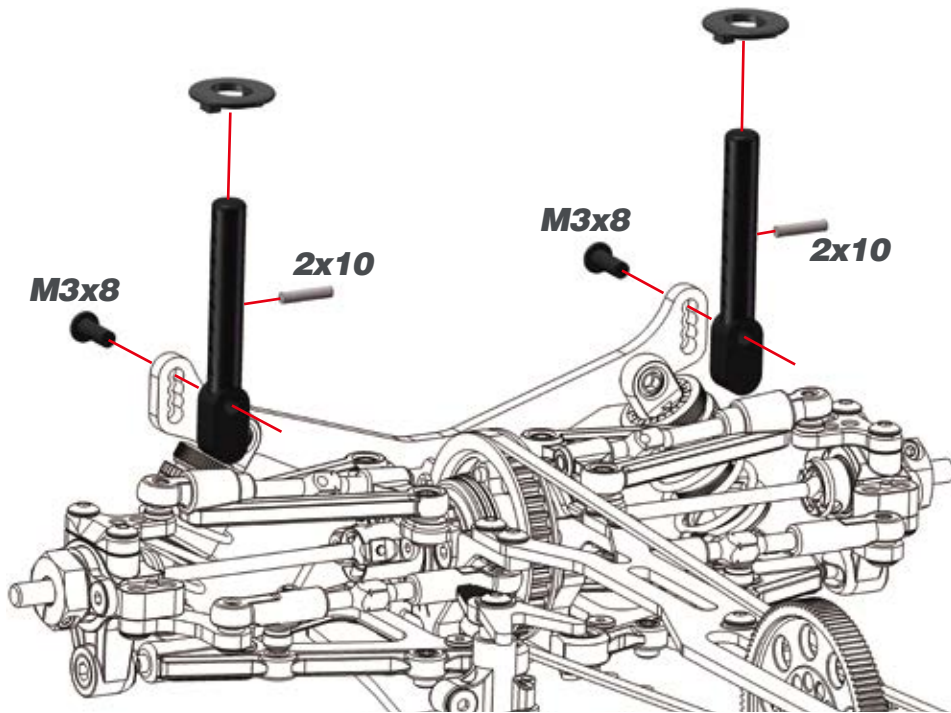

or

### 14.5

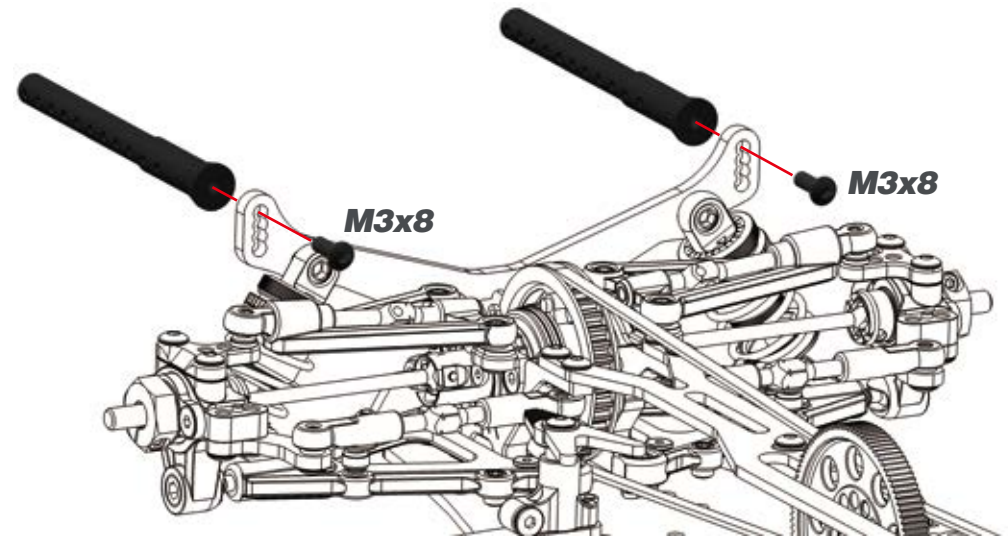



## STEP 15

### 15.1

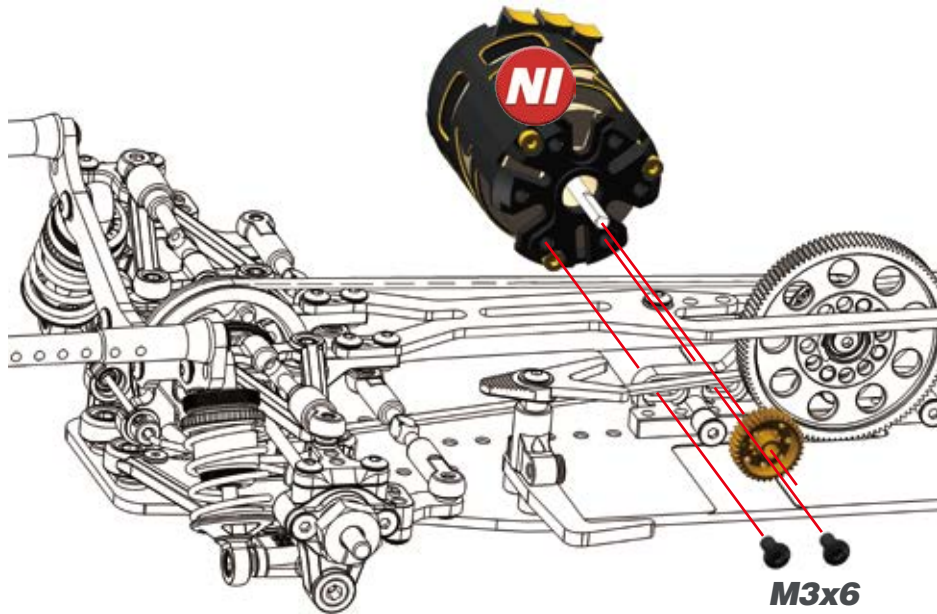

M3x6

### 15.2



Lock the pinion screw from that way.

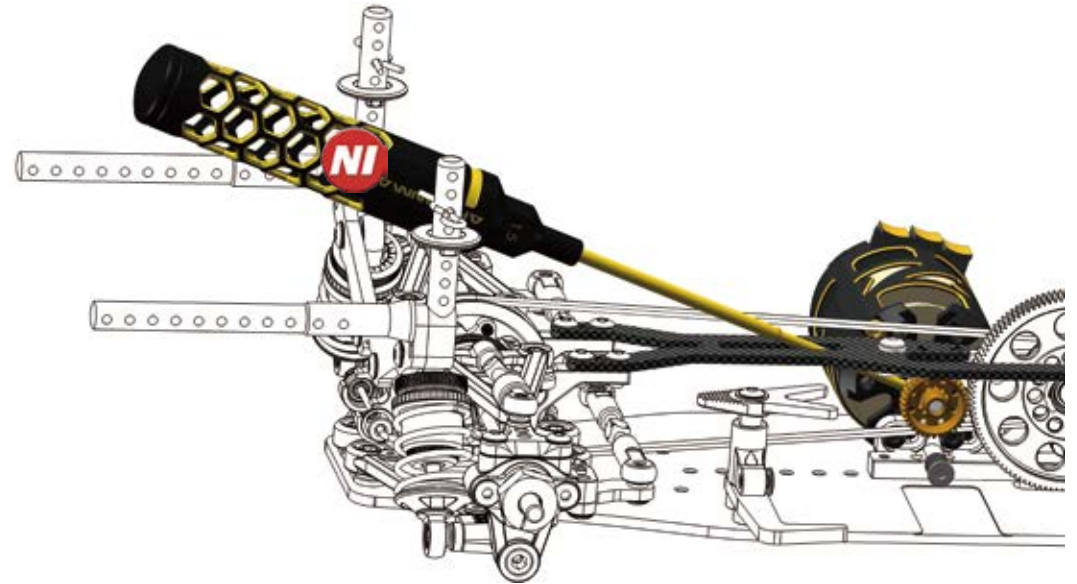

## STEP 15

### 15.3

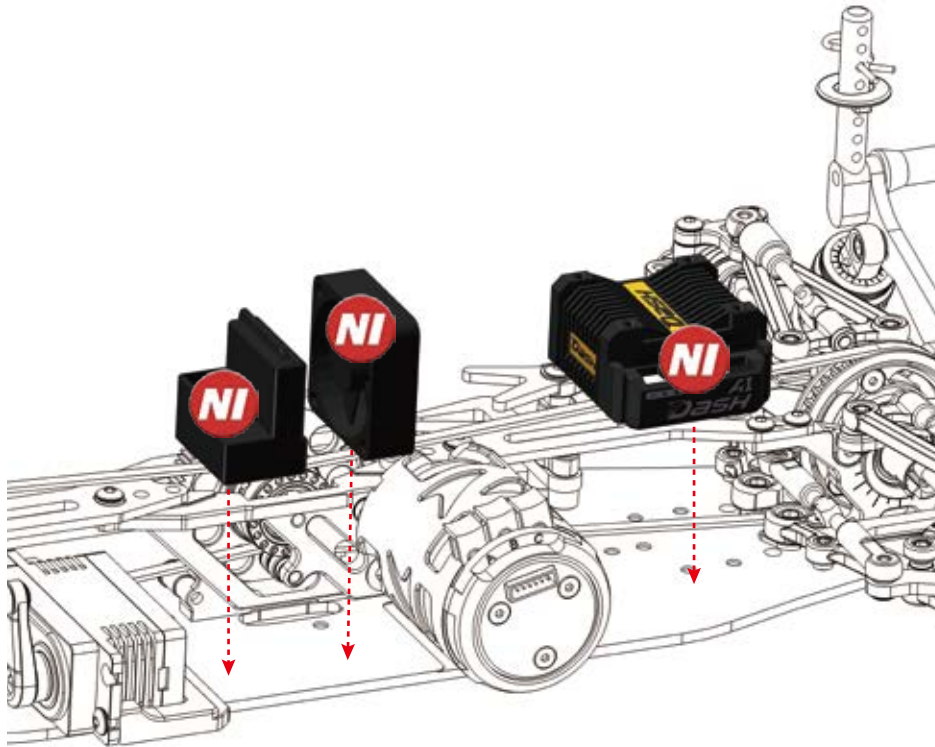

### 15.4

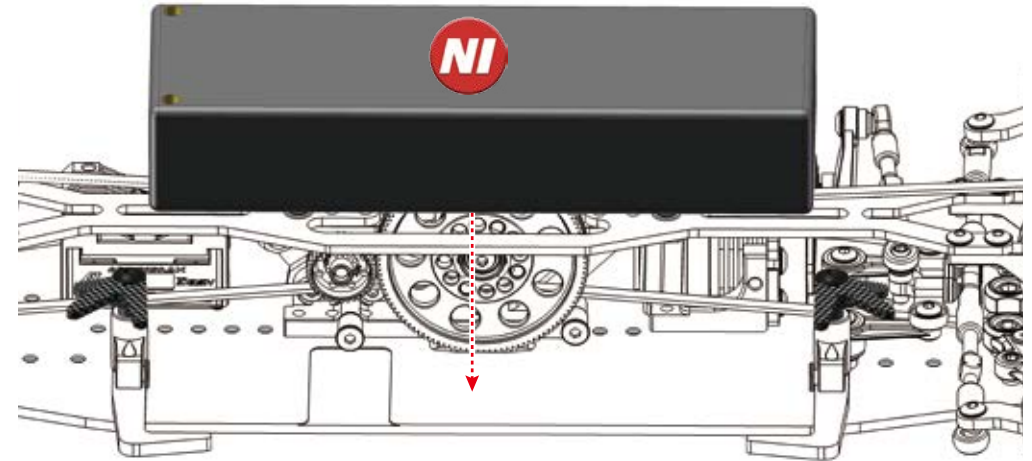
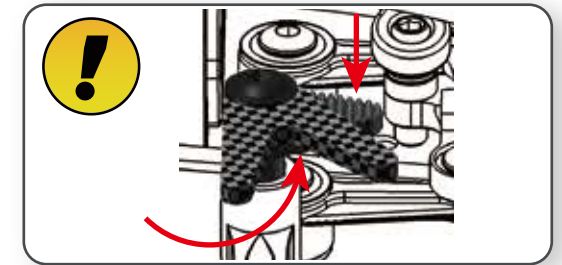

## STEP 15

### 15.5

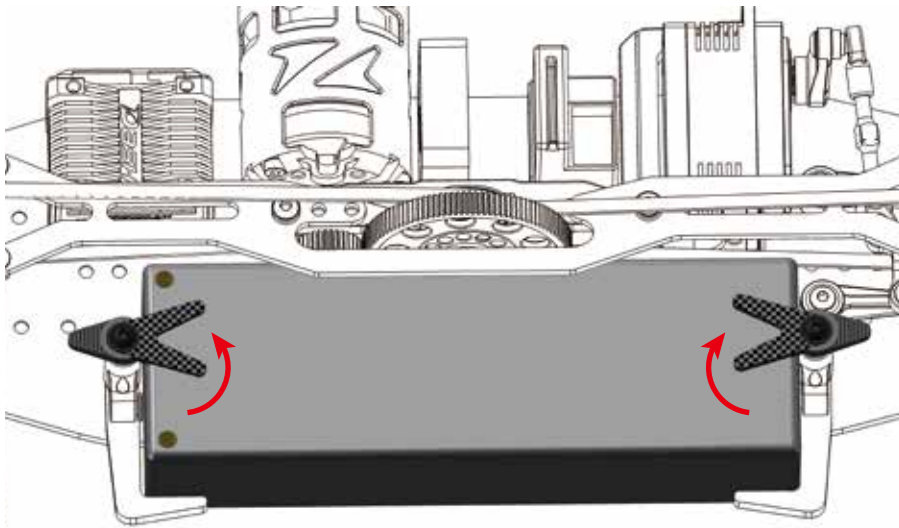

### 15.6

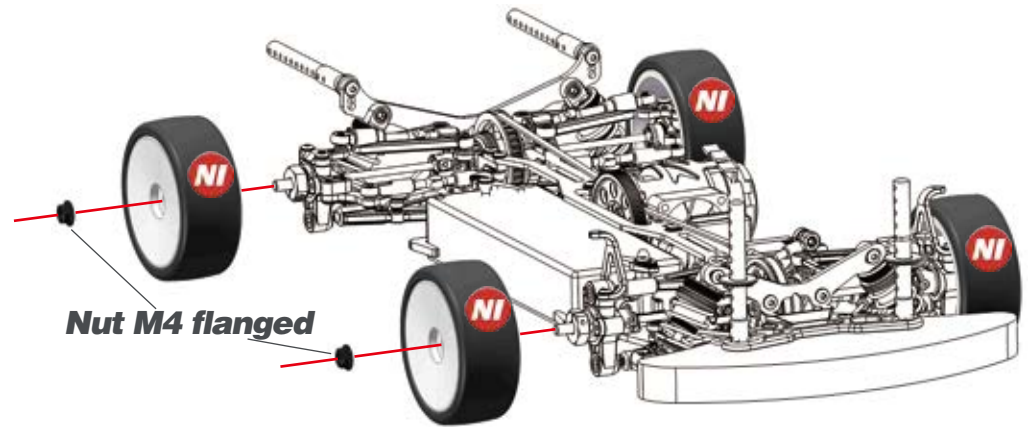

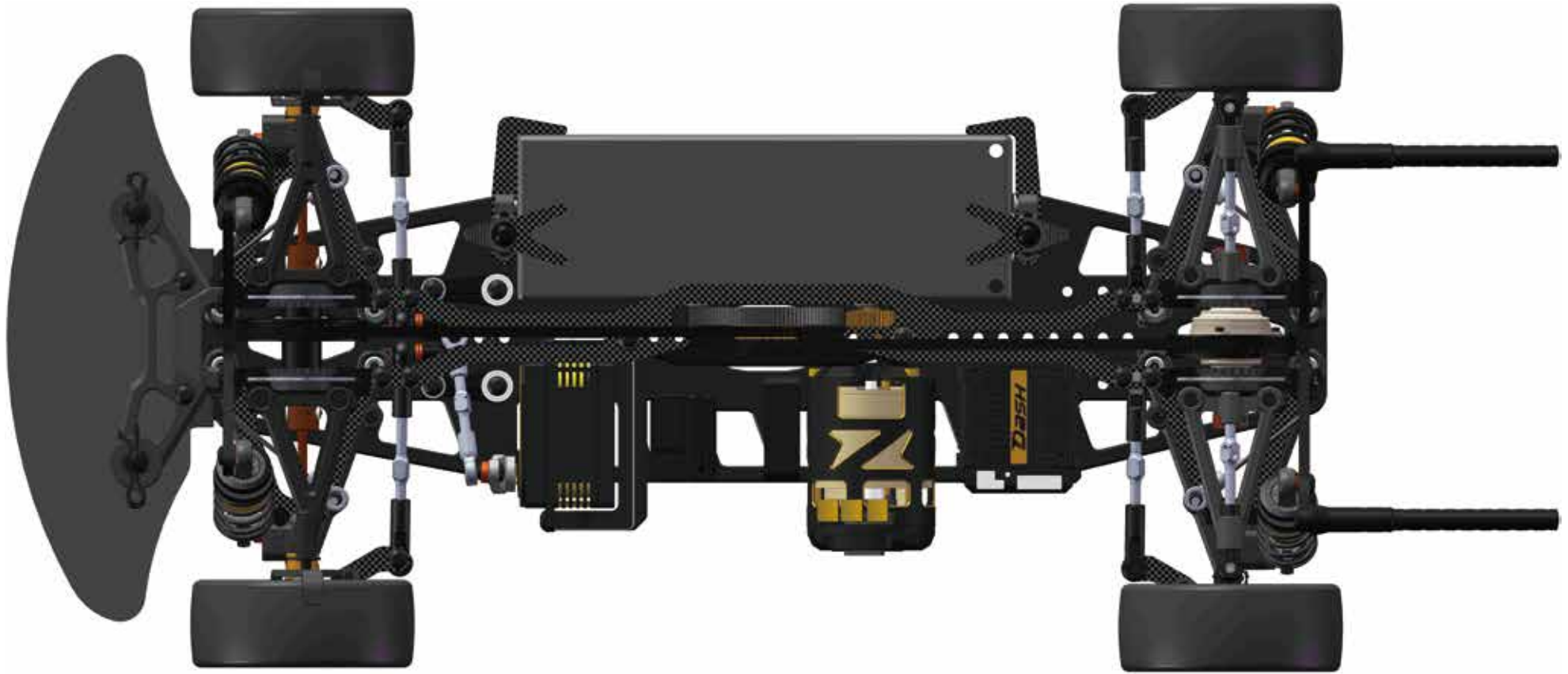



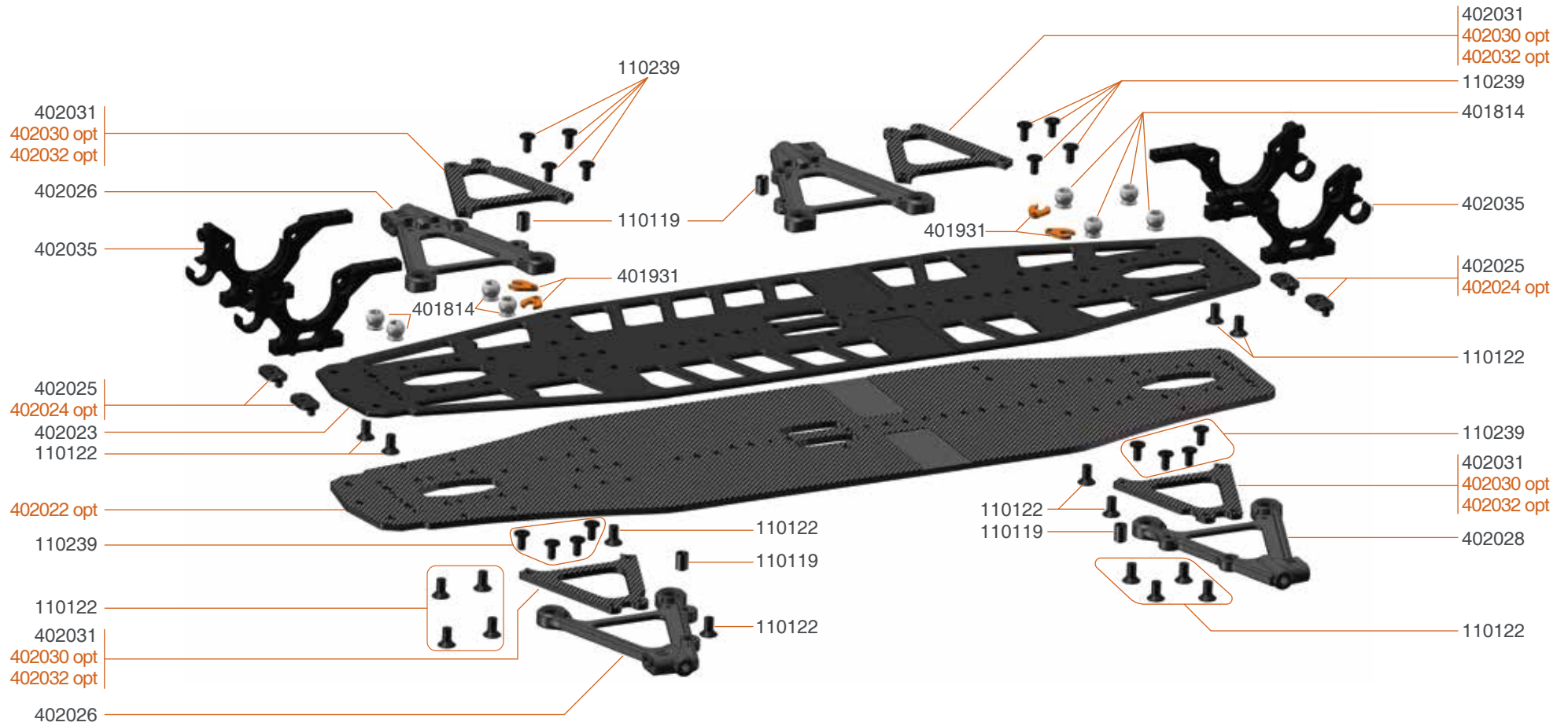

- 402022 Chassis 2.25mm carbon X20 '23
- 402024 Suspension insert lw 0.5deg (4) X20 '23
- 402030 Wishbone stiffener carbon S (4) X20 '23
- 402032 Wishbone stiffener carbon H (4) X20 '23

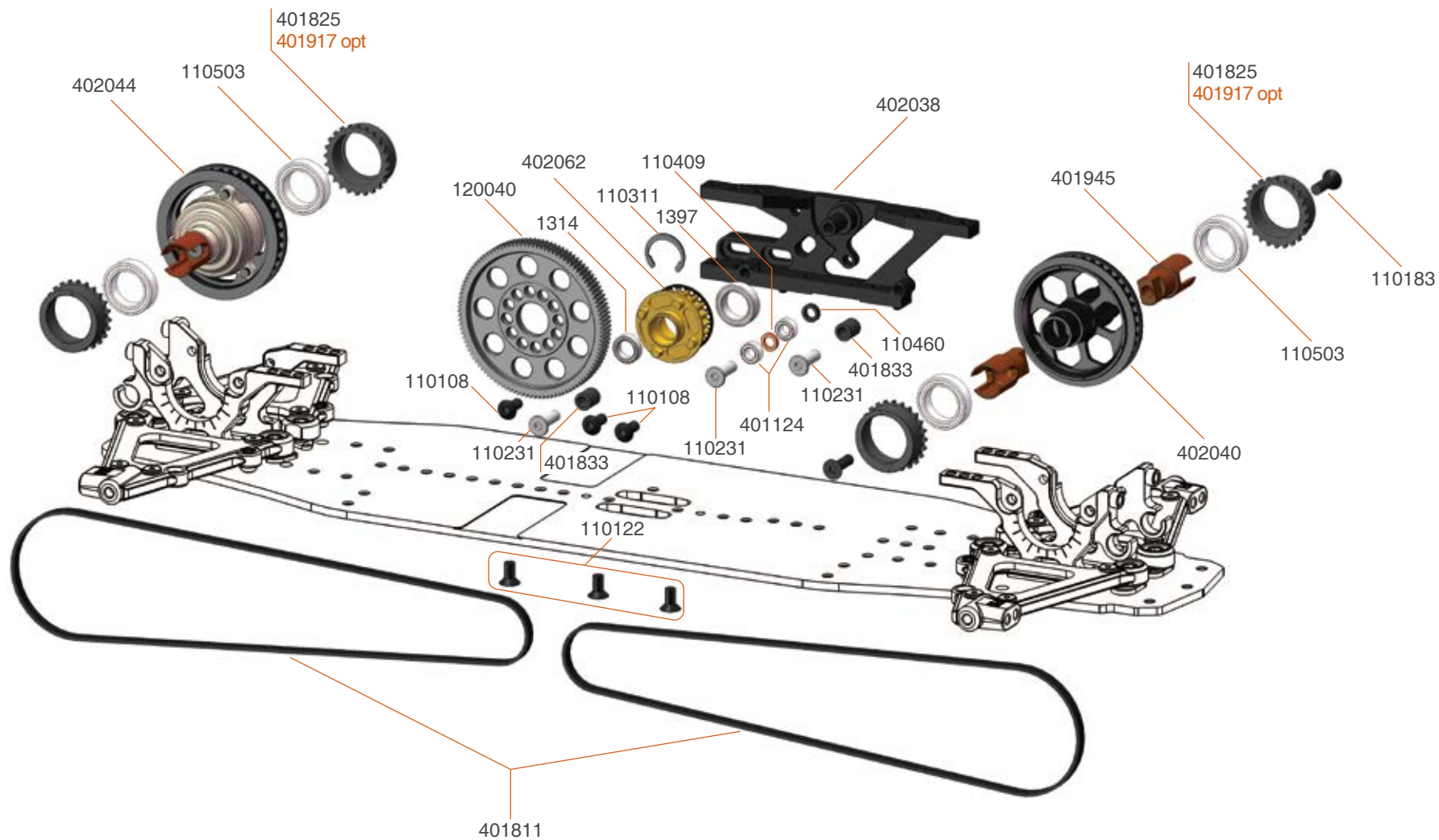

- 401917 Bearing excenter fr/r (4) alu X20
- 402066 Motormount weight 5gr X20 '23
- 402067 Motormount weight 10gr X20 '23

- 120007 Spur gear 64P / 100T
- 120008 Spur gear 64P / 104T
- 120009 Spur gear 64P / 108T

- 120010 Spur gear 64P / 112T
- 120012 Spur gear 64P / 114T
- 120013 Spur gear 64P / 106T

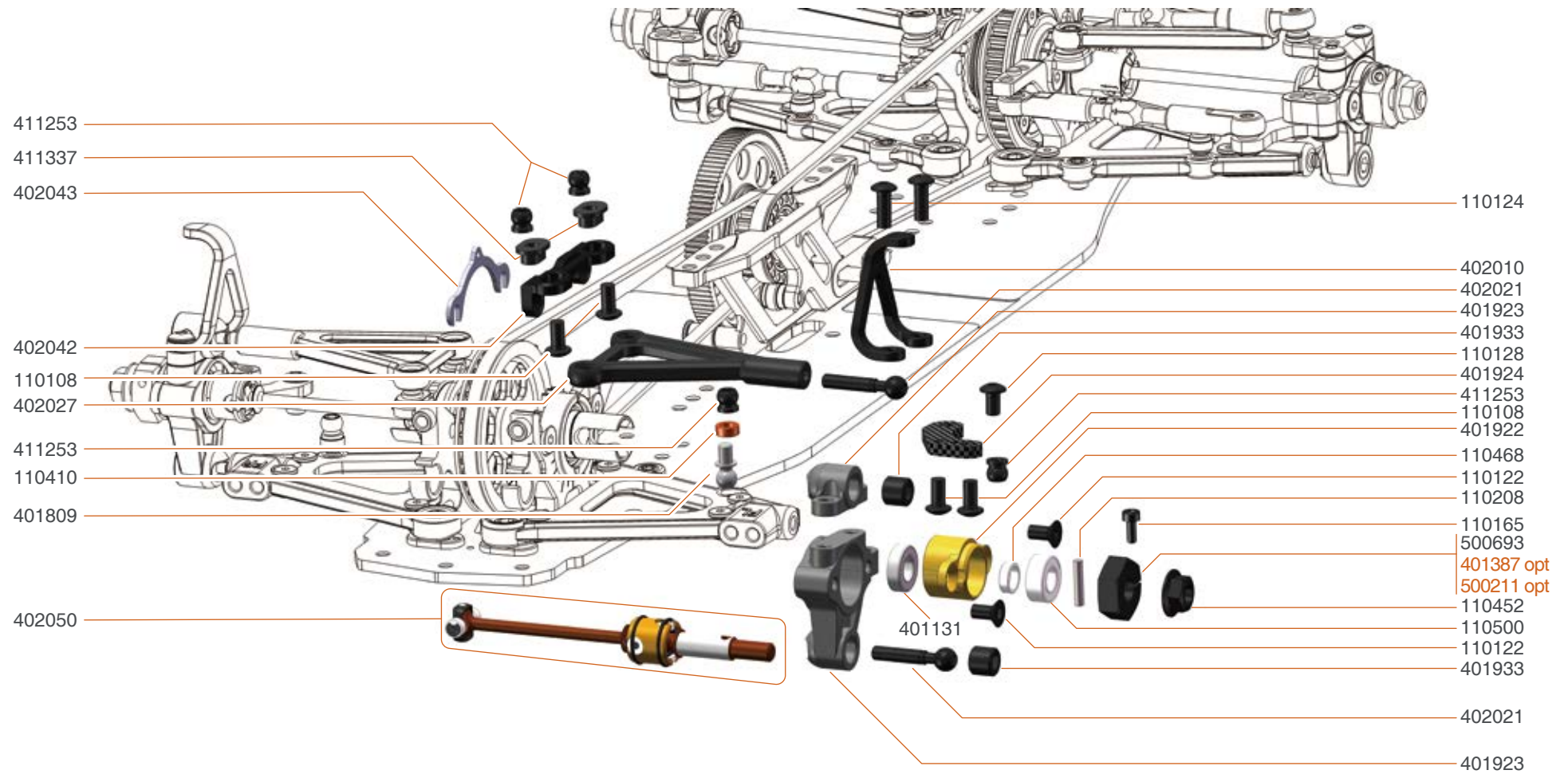

401387 Wheelhexagon 1mm offset (2)  
 500211 Wheelhexagon +0.75mm offset (2)



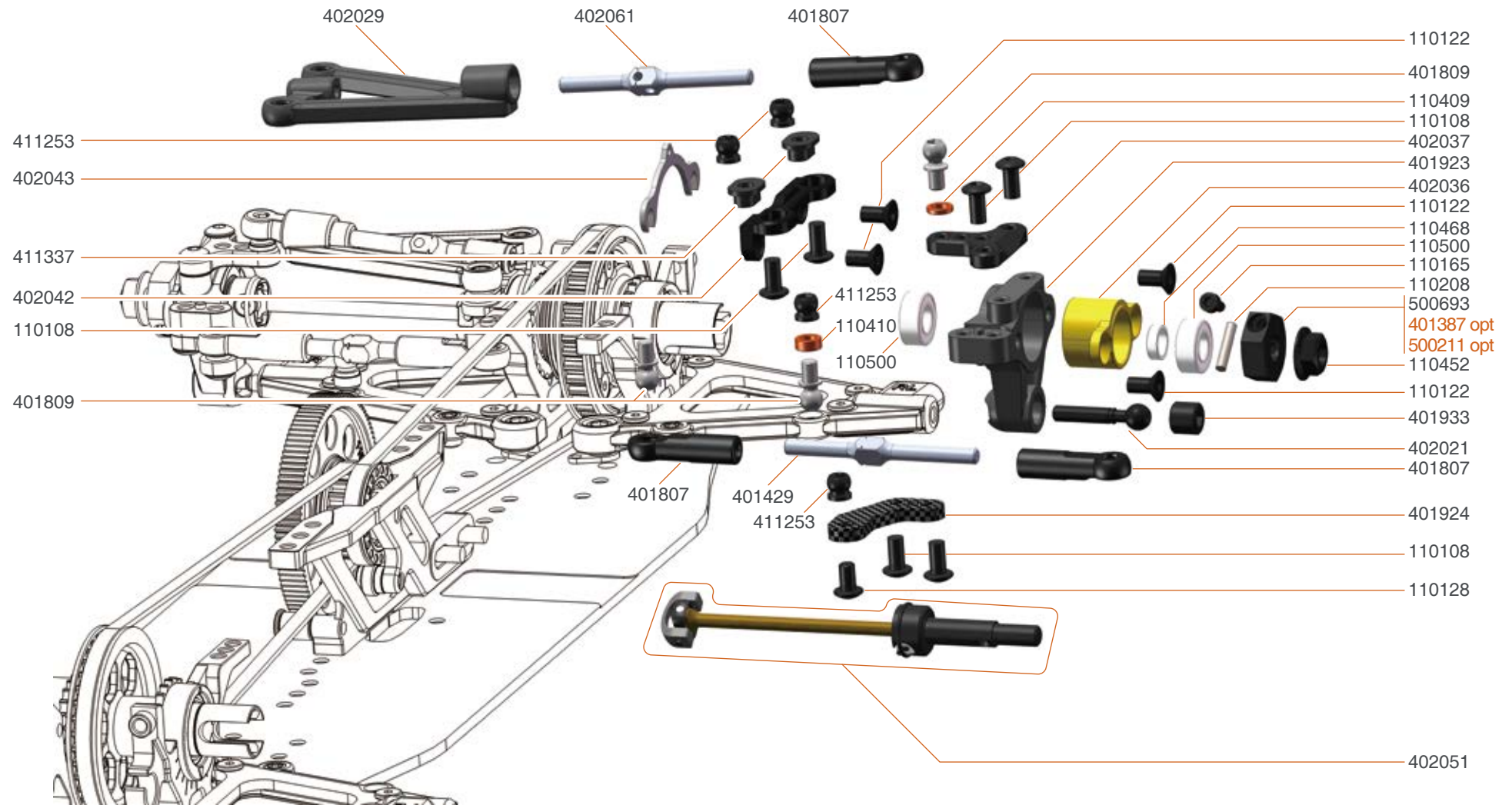

401387 Wheelhexagon 1mm offset (2)  
 500211 Wheelhexagon +0.75mm offset (2)





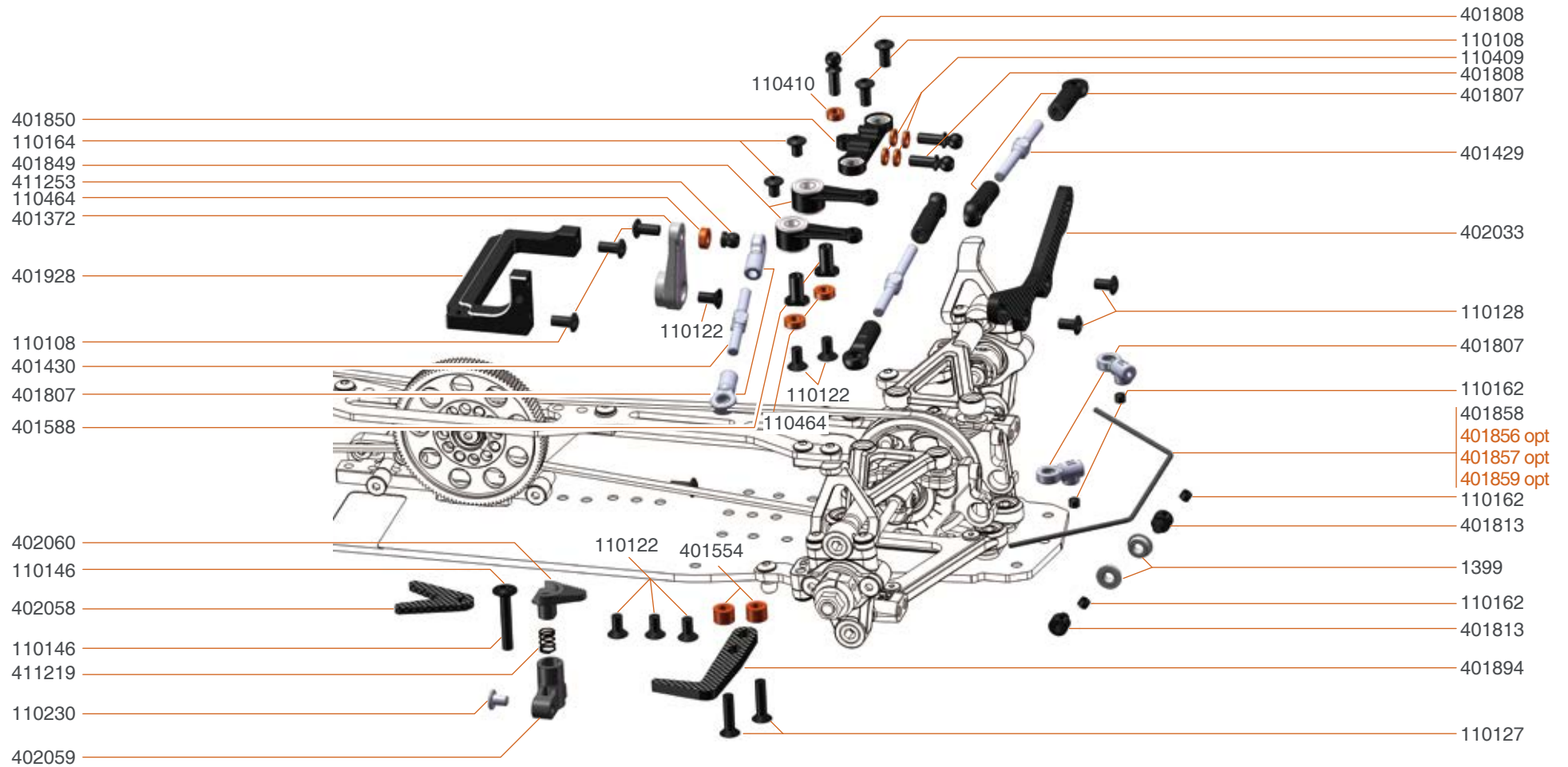

- 401856 Antirollbar 1,2mm X20
- 401857 Antirollbar 1,3mm X20
- 401859 Antirollbar 1,5mm X20

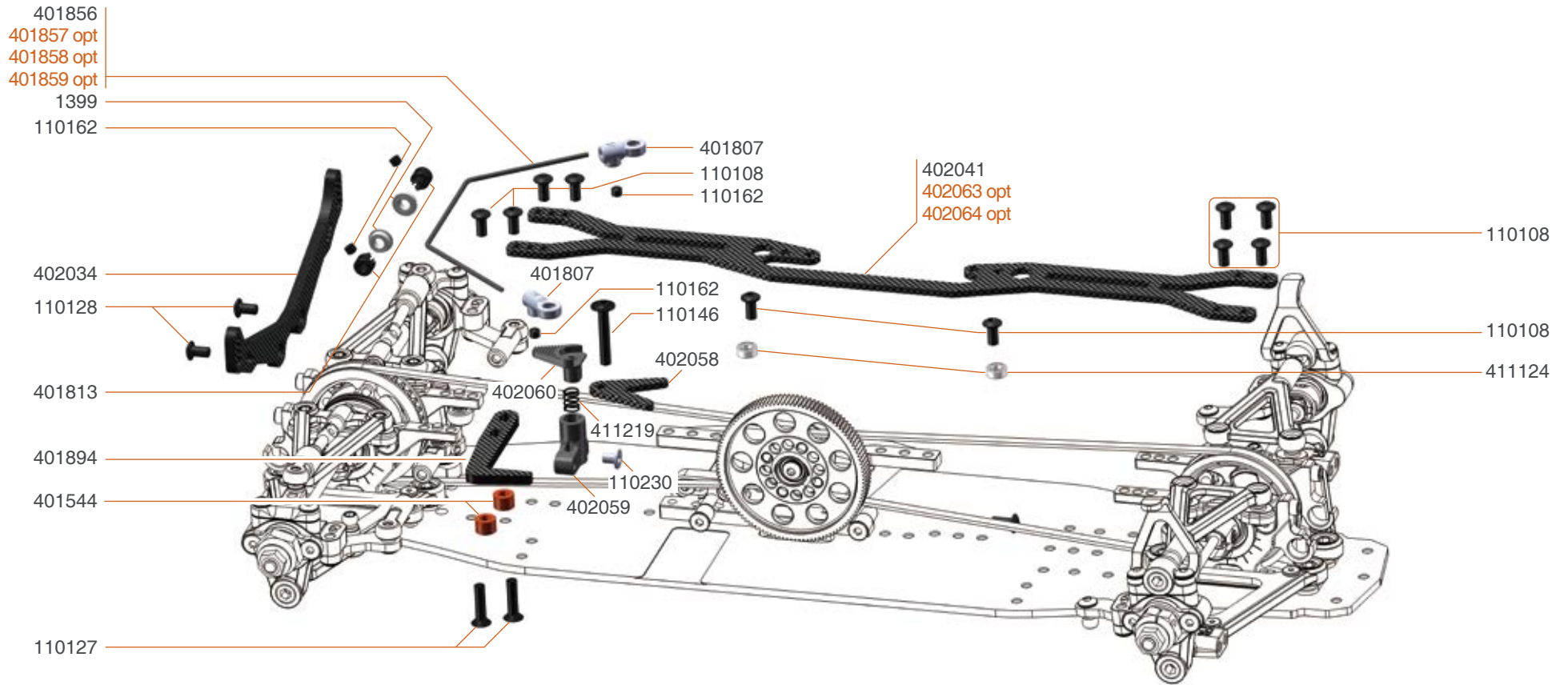

401857 Antirollbar 1,3mm X20  
 401858 Antirollbar 1,4mm X20  
 401859 Antirollbar 1,5mm X20

402063 Topdeck carbon soft set X20 '23  
 402064 Topdeck carbon hard set X20 '23



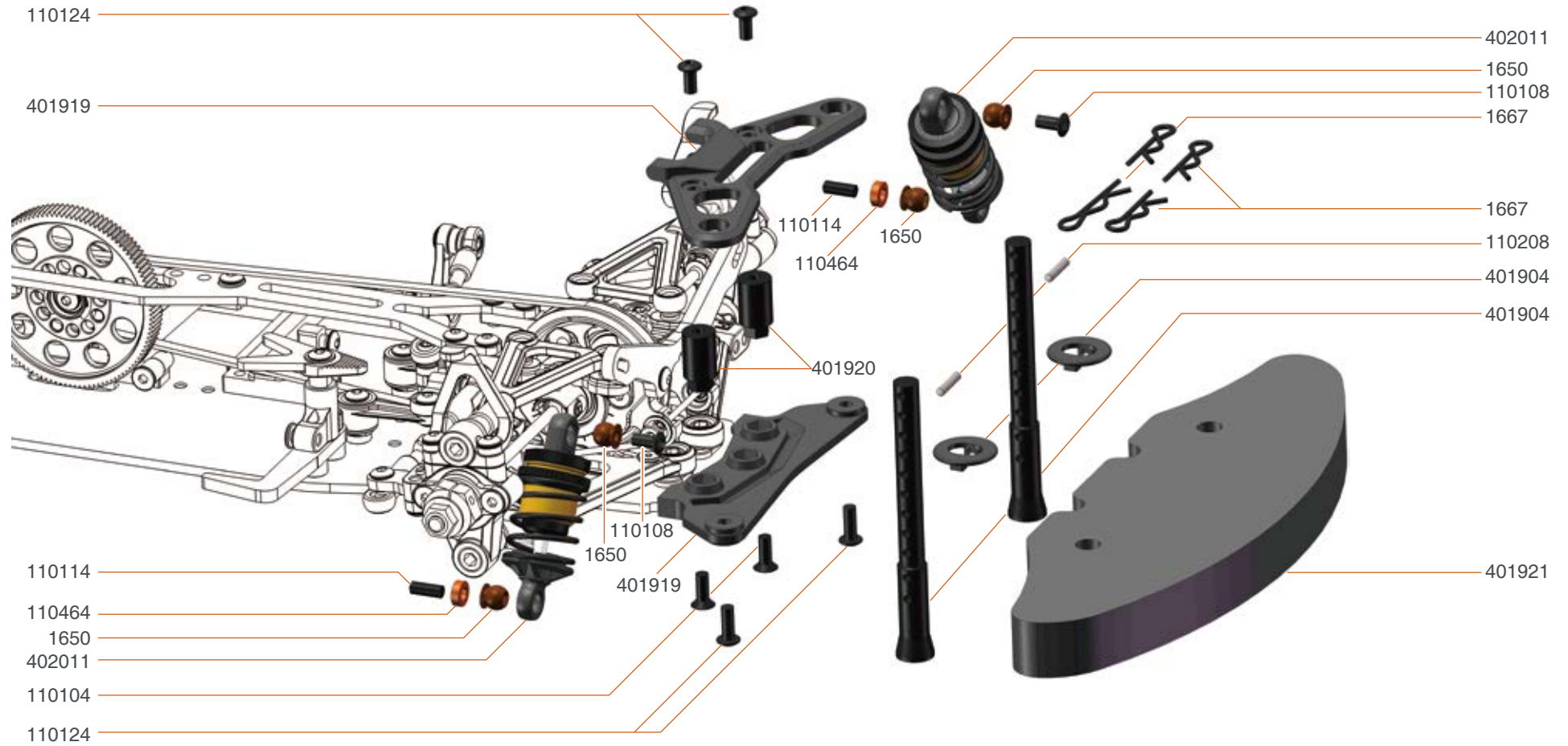

401997 Bumperset carbon X20 '21



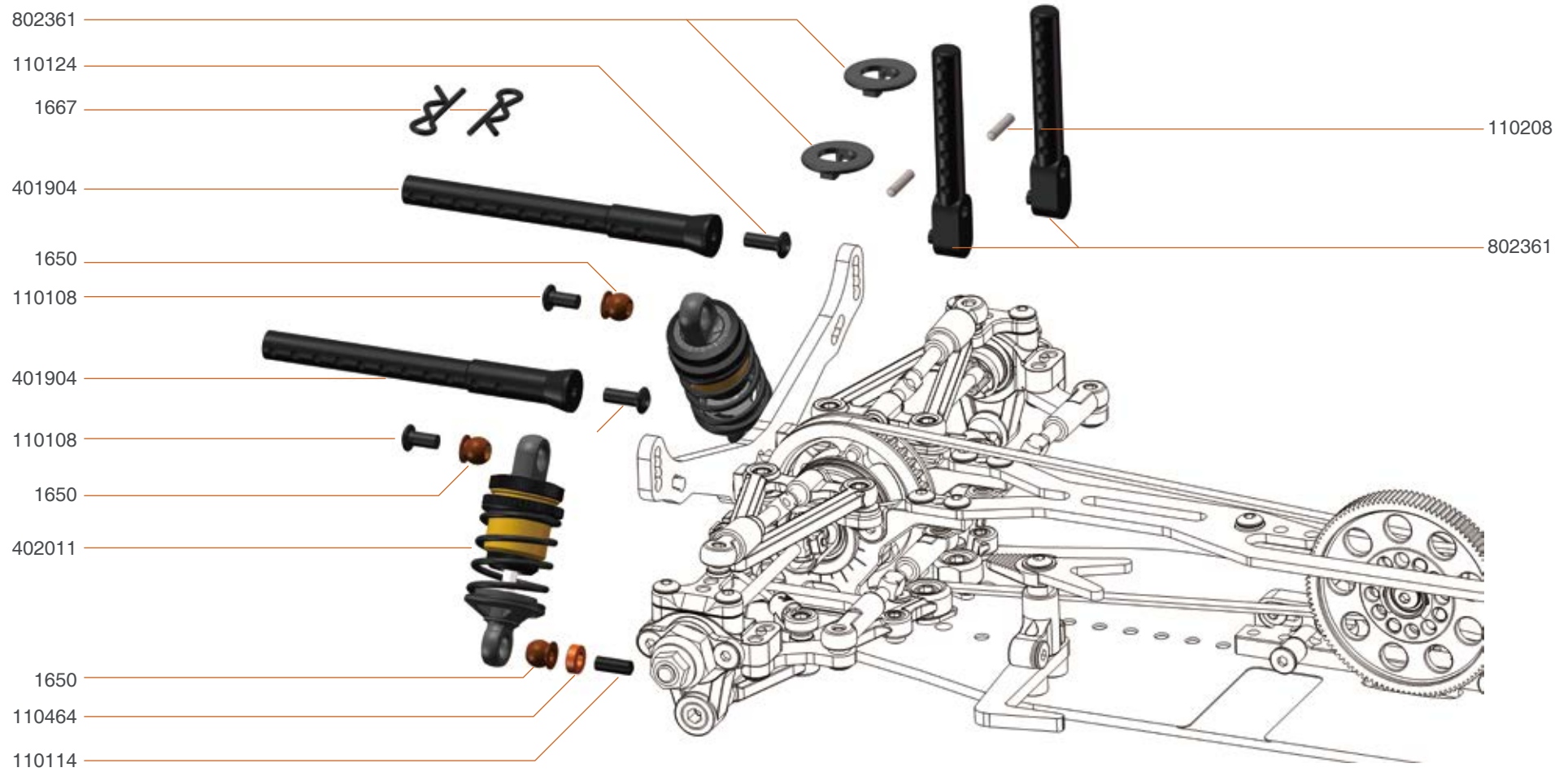



402050 DJC BB driveshaft set (2) X20 '23  
 402051 CVD BB driveshaft set (2) X20 '23

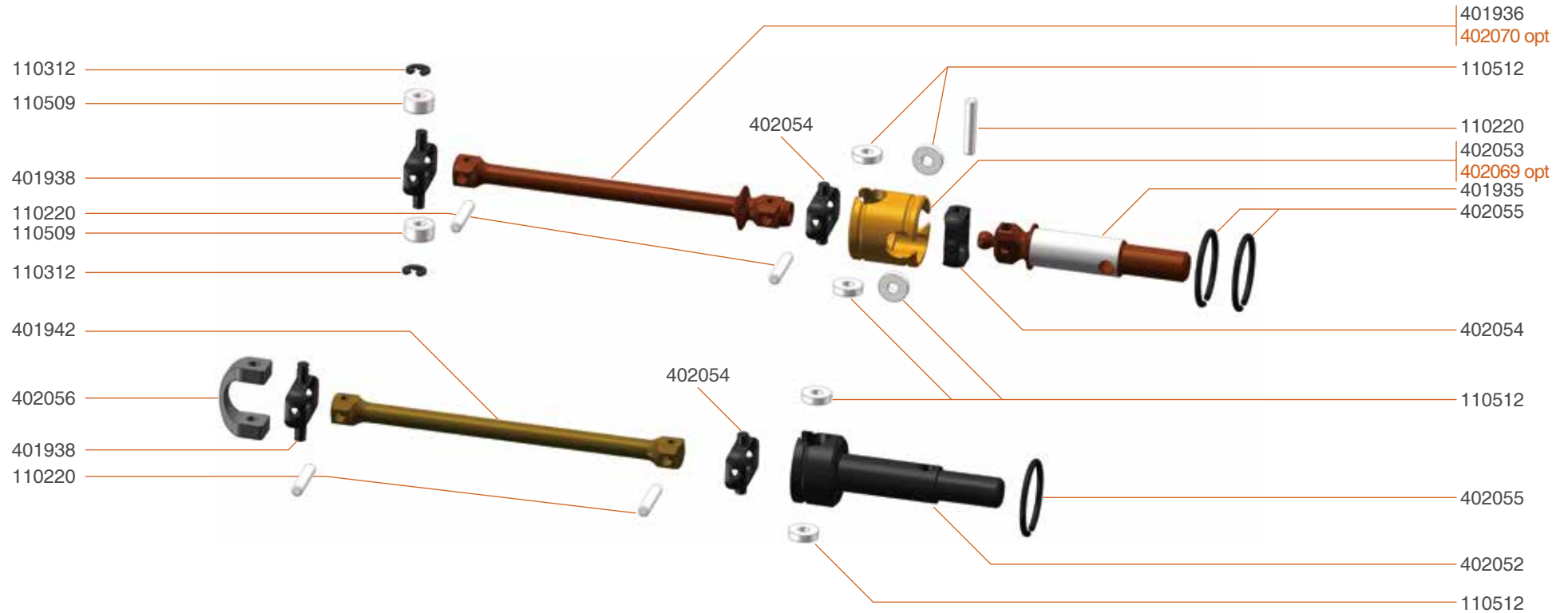

402069 DJC sleeve BB axle (2) X20 '23  
 402070 DJC driveshaft BB alu (2)



402011 Shockset (2) X20 '23

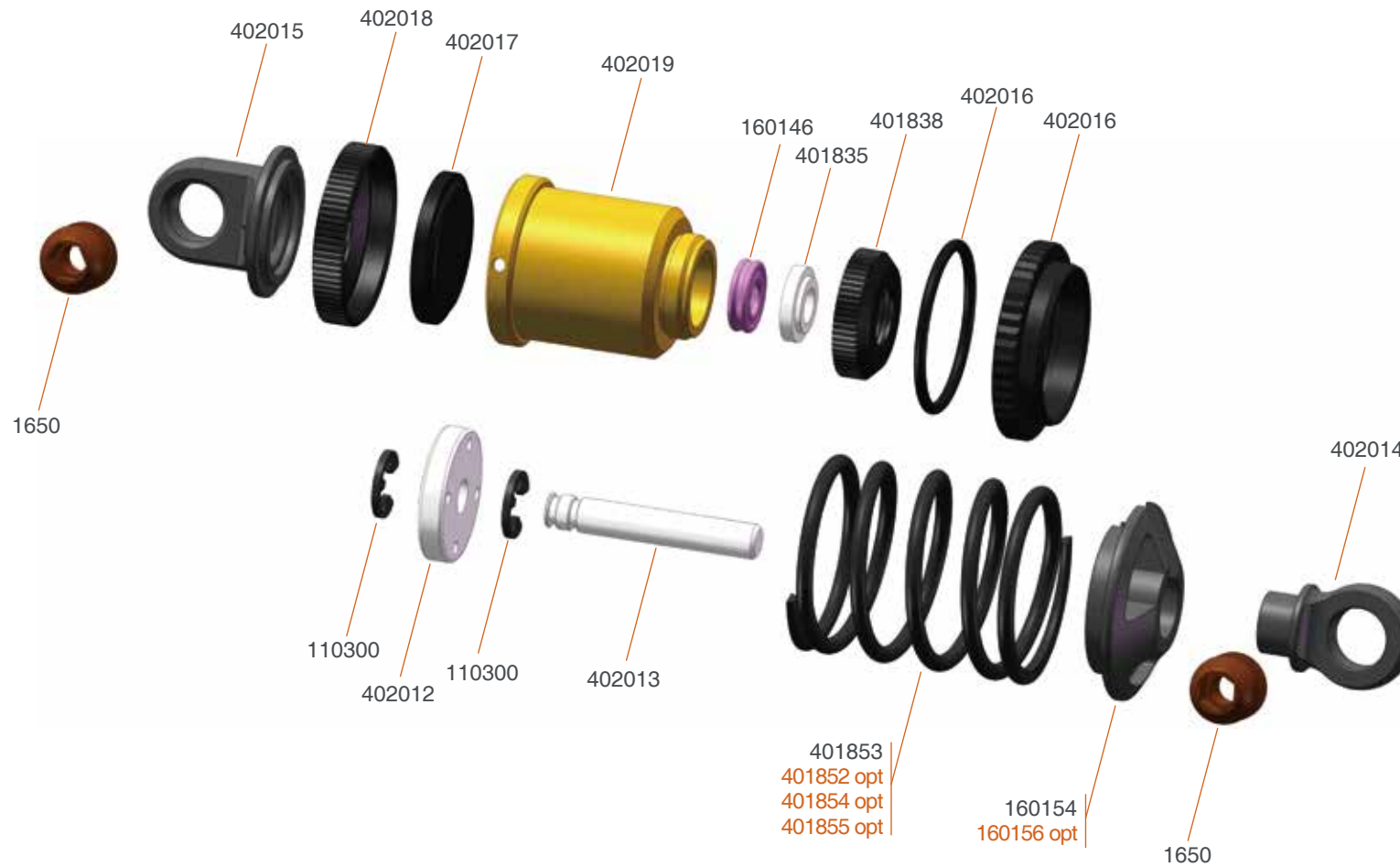

- 401852 Spring fr/rr 2,5 (2)
- 401854 Spring fr/rr 2,7 (2)
- 401855 Spring fr/rr 2,8 (2)
- 160156 Shock spring support low onroad alu (4)

402044 Geardiff set alu X20 '23



401784 Seal 5x9x2 diff (2)



# TEAM SERPENT NETWORK

## X20' 23 SPARE PARTS

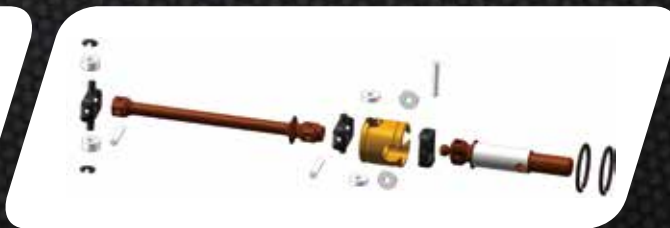

## X20' 23 OPTIONAL PARTS



## SERPENT TOOLS



## SERPENT MERCHANDISING





## SERPENT WEBSITE AND BLOG

[www.serpent.com](http://www.serpent.com)

[www.teamserpent.com](http://www.teamserpent.com)

[www.dragon-rc.com](http://www.dragon-rc.com)

**SERPENT PROMO PAGES** <http://promo.serpent.com>

## SERPENT SOCIAL MEDIA



[www.facebook.com/SerpentMRC](http://www.facebook.com/SerpentMRC)



[www.youtube.com/user/SerpentMRC](http://www.youtube.com/user/SerpentMRC)

# *INSTRUCTION MANUAL*



Manual Medius X20 '23 alu #98672-1

# *SERPENT*