



TRUGGY SRX8

SCALE 1/8 GAS

SERPENT
INNOVATIONS

INTRODUCTION

Thank you very much for selecting this Serpent rc car and thus become a member of the ever growing worldwide Serpent racing family. Serpent started in 1980 and has been growing its product-line and fan-base ever since.

The Serpent SRX8T is a state of the art 1/8 scale 4wd Truggy which will give you the true Serpent racing experience. The assembly manual will guide you through all the steps to complete the car, so you can hit the track with a good base-set-up soonest. The Serpent design department succeeded to create a superbly performing car combined with ease of assembly and maintenance. The high quality standards of all parts and hardware will make racing your Serpent car a very rewarding activity !

Through our team, website and social media we will keep you up-to-date on all developments of the Serpent cars. We hope to meet you on the track and through our various media! Enjoy the drive !

Team Serpent
Multiple World Champions

INSTRUCTIONS

Serpent's long tradition of excellence extends to the instruction manuals, and this instruction manual is no exception. The easy-to-follow layout is richly illustrated with 3D-rendered full-color images to make your building experience quick and easy. Following the instructions will result in a well-built, high-performance race-car that will soon be able to unleash its full potential at the racetrack. The kit includes bags, with bag numbers, which refer to the same step in the manual. Open only the indicated bag(s) per step and finish that part of the assembly. Remaining parts will be needed later on in the assembly process.

PLASTIC PARTS

The Serpent moulded parts are very durable and hard. When assembling longer screws in new composite parts, make sure to use new hex bits in your (power) tools. Pre-threading also helps to avoid screw damage.

SETUP

In certain assembly steps you need to make basic adjustments, which will give you a good initial setup for your Serpent SRX8T. Fine-tuning the initial setup is an essential part of building a high-performance race car like your Serpent SRX8T.

EXPLODED VIEWS AND PARTS LIST

The exploded views and parts lists for the Serpent SRX8T are presented in the Reference Guide section in the back of this manual. The exploded views show all the parts of a particular assembly step along with the Serpent part number and hotlink to the Serpent website. Part numbers in orange indicates that this part is an optional. Optionals part names and numbers are showed below.

CUSTOMER SERVICE

Serpent has made a strong effort to make this manual as complete and clear as possible. Additional info may be published in our website: www.serpent.com or you may ask your dealer or the Serpent distributor for advice, or email Serpent direct: info@serpent.com. The Serpent Facebook, Twitter and Youtube pages give additional means of support and communications.

SAFETY

Read and take note of the 'Read this First section' before proceeding to assemble the car-kit. This car-kit is intended for persons aged 16 or older.

READ THIS FIRST!

- This is a highly technical hobby product, intended to be used in a safe racing environment. This car is capable of speeds in excess of 80 km/h or 50mph. Please follow these guidelines when building and operating this model.
- Parental guidance is required when the builder/user of this car is under 16.
- Follow the building instructions. If in doubt, contact your dealer or importer.
- Be sure to use the proper tools when assembling the car. Always exercise caution when using electric tools, knives and other sharp objects.
- Be careful when using liquids like lubrication oil, fuel or glue. Do not swallow.
- Follow the manufacturer's instruction in case you experience irritation after using the product.
- Be careful when operating the car. Stay away from any rotating parts such as wheels, gears and transmission. Stay away from motor, engine and exhaust pipe system or speedo during and immediately after use, as these parts may be very hot. We advise to use protective hand gloves.
- Only operate this car in a safe environment, like a special racing track or a closed parking lot. Avoid using this car on public roads, crowded places or near infants.
- Before operating this car, always check the mechanical status of the car. Also check that the transmitter and receiver frequencies correspond and are not used by any other racer at the same time. Check that the batteries of the transmitter and receiver- are fully charged.
- After use, always check all the mechanics of the car. We advise to clean the car immediately after use, and inspect the parts for wear or fractures. Replace when necessary. Do not use water, methanol, thinner or other solvents to clean the car.
- Empty the fuel tank (depending on model) if needed and disconnect the receiver battery.
- Store the car in a dry and heated place to avoid corrosion of metal parts.
- Avoid using this car in wet conditions as the water will cause corrosion on the metal parts and bearings and these parts will cease to function properly. If driven in the wet, ensure that all the electric equipment is waterproofed and after use, that all moving parts are dried immediately.

CONTENTS

• CENTER DIFF ASSEMBLY	4
• FR/RR DIFF ASSEMBLY	6
• CENTRAL ASSEMBLY	8
• REAR ASSEMBLY	11
• FRONT ASSEMBLY	18
• STEERING ASSEMBLY	24
• RADIO ASSEMBLY	28
• SHOCK ASSEMBLY	32
• FINAL ASSEMBLY	35
• CLUTCH ASSEMBLY	36
• EXPLODED VIEWS	42
• TEAM SERPENT NETWORK	53

LINES DESCRIPTION

Each step contains a variety of numbers, lines, and symbols. The numbers represent the order in which the parts should be assembled. The lines are described below.



Step number; the order in which you should assemble the indicated parts



Length after assembly



Assembly path of one item into another



Group of items (within lines) should be assembled first



Direction the item should be moved



Glue one item to another



Press/insert one item into another



Connect one item to another



Gap between two items

ICONS DESCRIPTION

Each step contains a variety of symbols described below.



Carefully, read and check extensively.



Apply a small amount of cyano glue. Use wear protection for eyes and hands.



Detail view to explain assembly or order of parts better.



Default set-up: This symbol indicates the default setup.



Grease: apply a small amount of grease to the parts shown.



Left and right parts should be assembled in the same way.



Thread lock: apply a small amount on the parts shown. Before to apply the threadlock, make sure to degrease the parts very well, as otherwise the threadlock will not work.



Silicone oil: use the indicated silicone oil for the shocks and differentials.



Parts or items not included in the kit.



Optional part, not standard in the kit.

CENTER DIFF ASSEMBLY

STEP 1 CENTER DIFF BAG

STEP 2

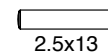
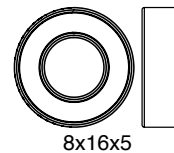
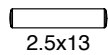
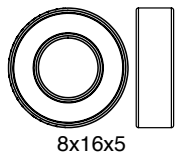
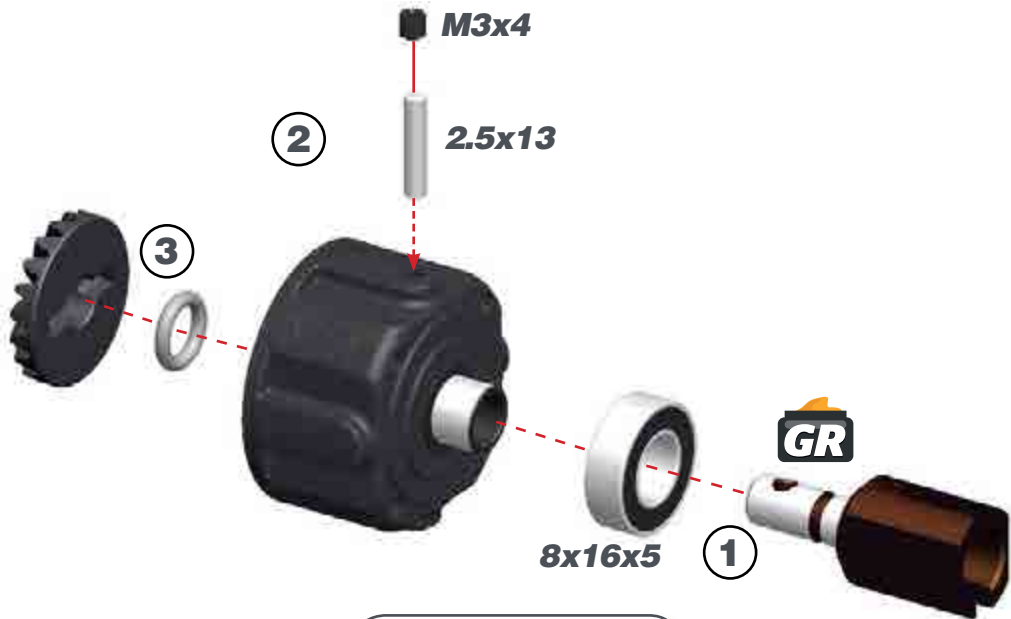

STEP 3

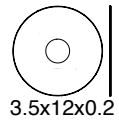
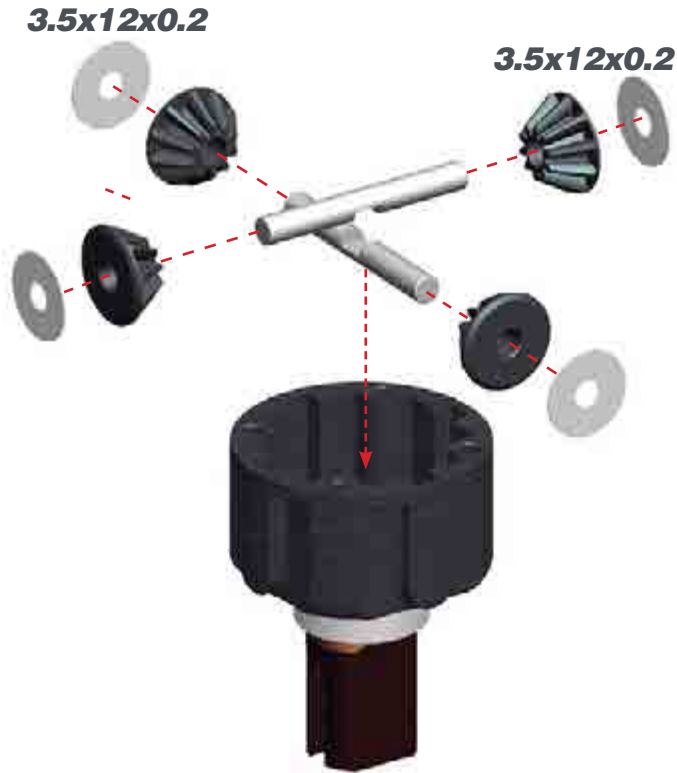

STEP 4



Fill the differential with silicone oil between 1 and 1.5 mm above the crosspin, do NOT overfill. Use the silicone oil supplied in the kit. For the correct cst value please check the default setupsheet.

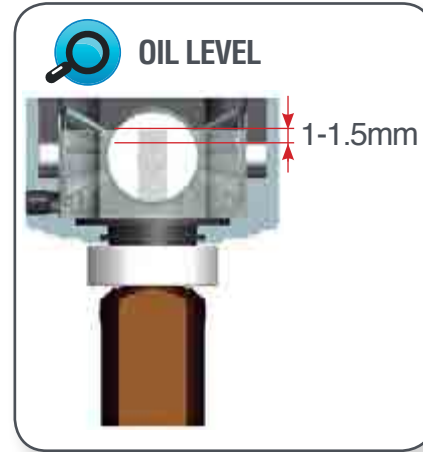

AMOUNT OF OIL IN THE DIFFS

Use a digital scale to measure the exact amount of oil in the diff.

Differential weight = 44.00 +/- 0.10 grams.



STEP 5

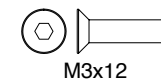
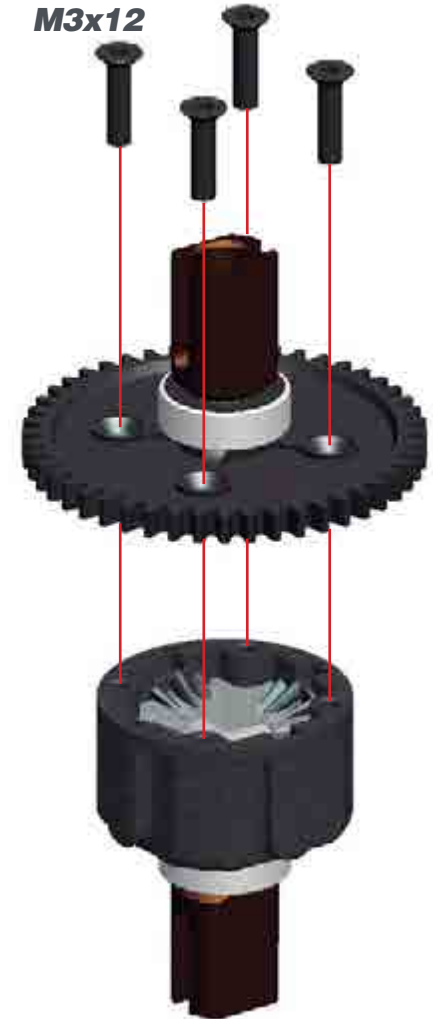

STEP 6 FR/RR DIFF BAG

STEP 7



Note the correct pin location.

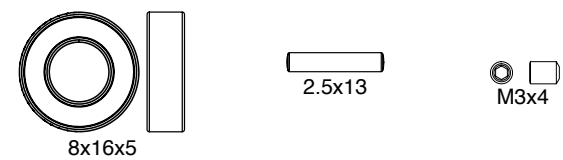
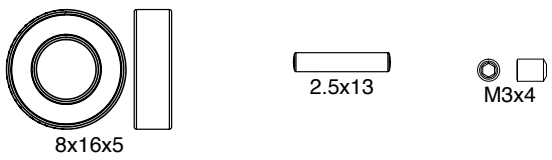
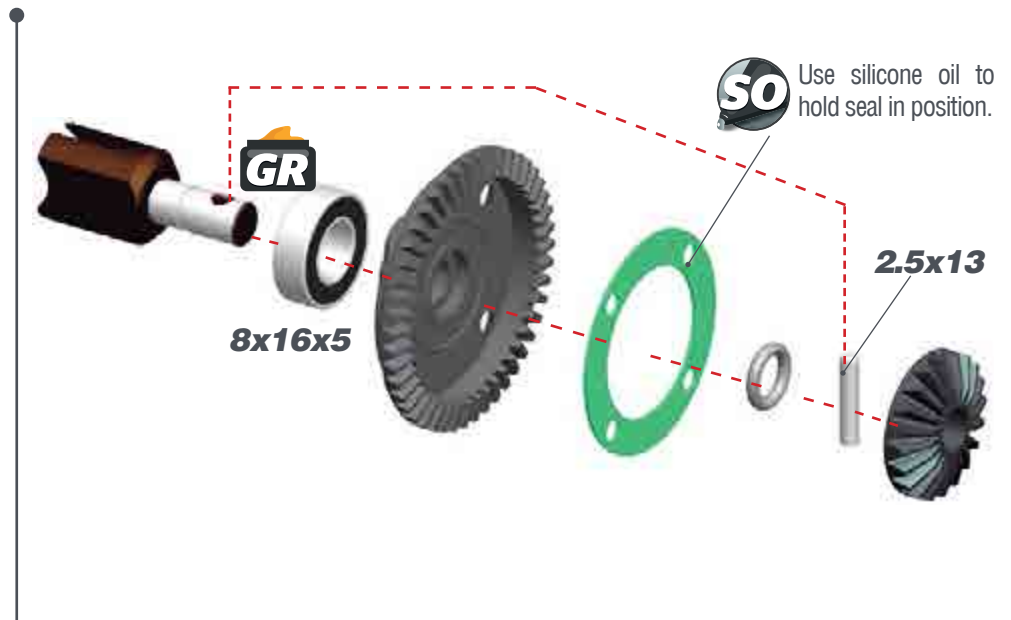

STEP 8

3.5x12x0.2

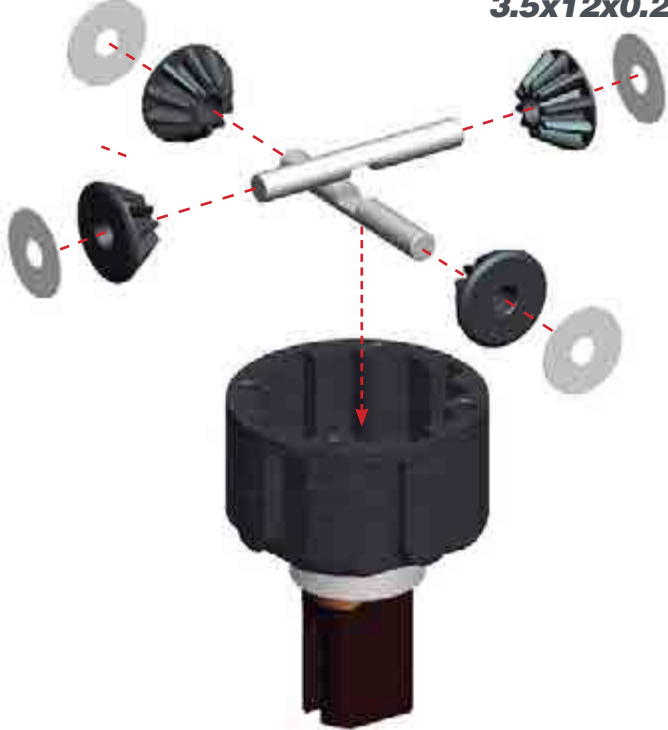

STEP 9

3.5x12x0.2



Fill the differential with silicone oil between 1 and 1.5 mm above the crosspin, do NOT overfill. Use the silicone oil supplied in the kit. For the correct cst value please check the default setupsheet.

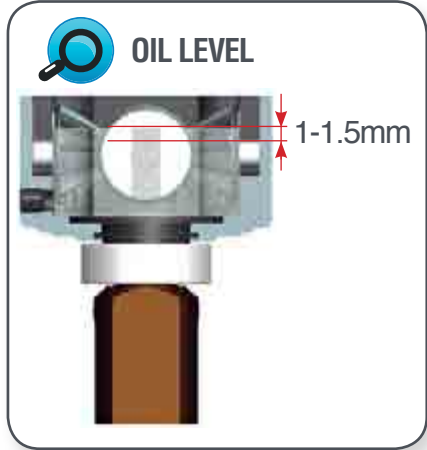

AMOUNT OF OIL IN THE DIFFS

Use a digital scale to measure the exact amount of oil in the diff.

Differential weight = 44.00 +/- 0.10 grams.



STEP 10

M3x12

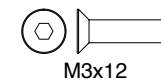
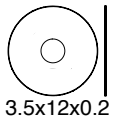

STEP 11

BAG 1

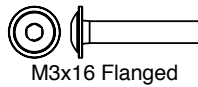
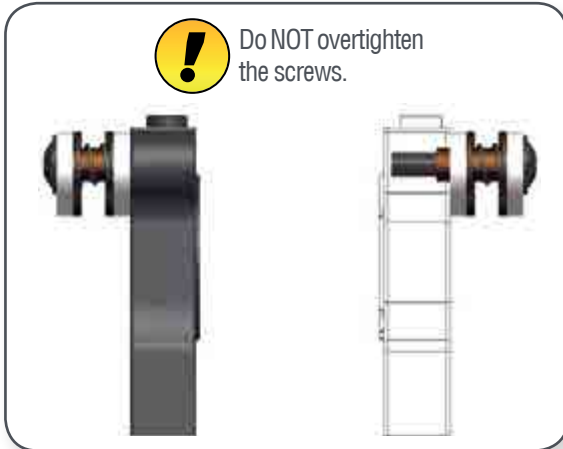
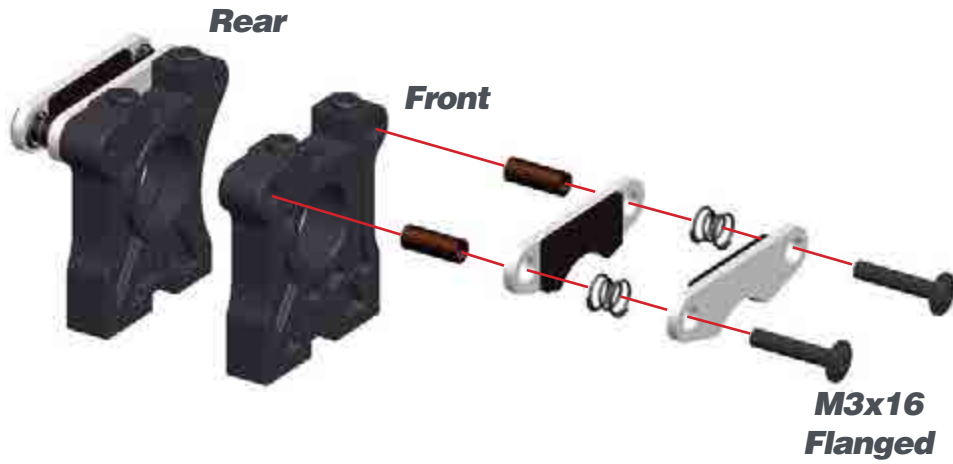

STEP 12

12.1

! Diff mounts are NOT symmetrical. Please check below picture to ensure front and rear bracket assembly are assembled properly.

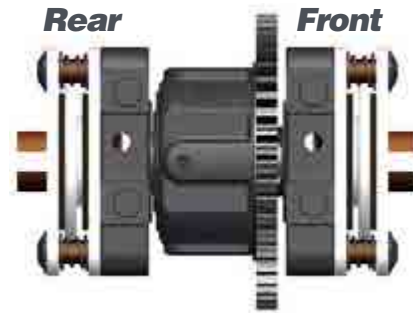

12.2

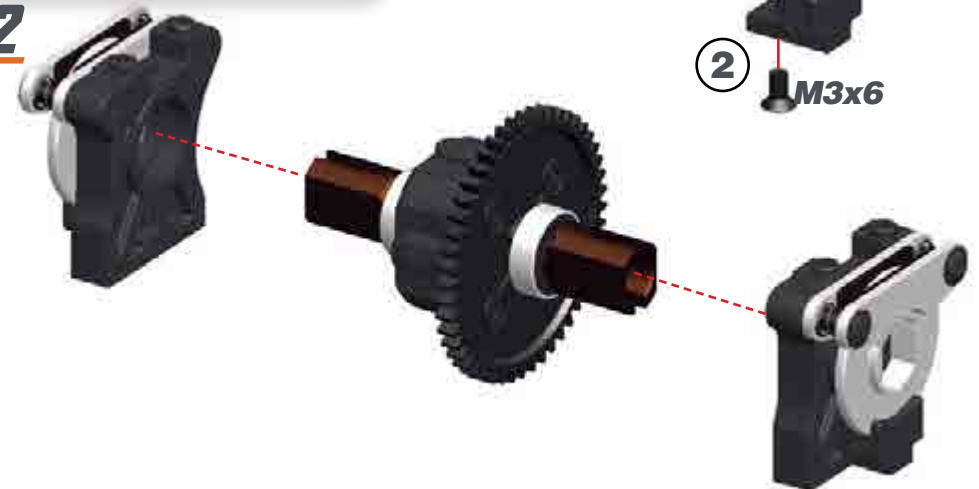

STEP 13

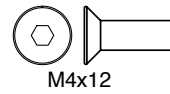
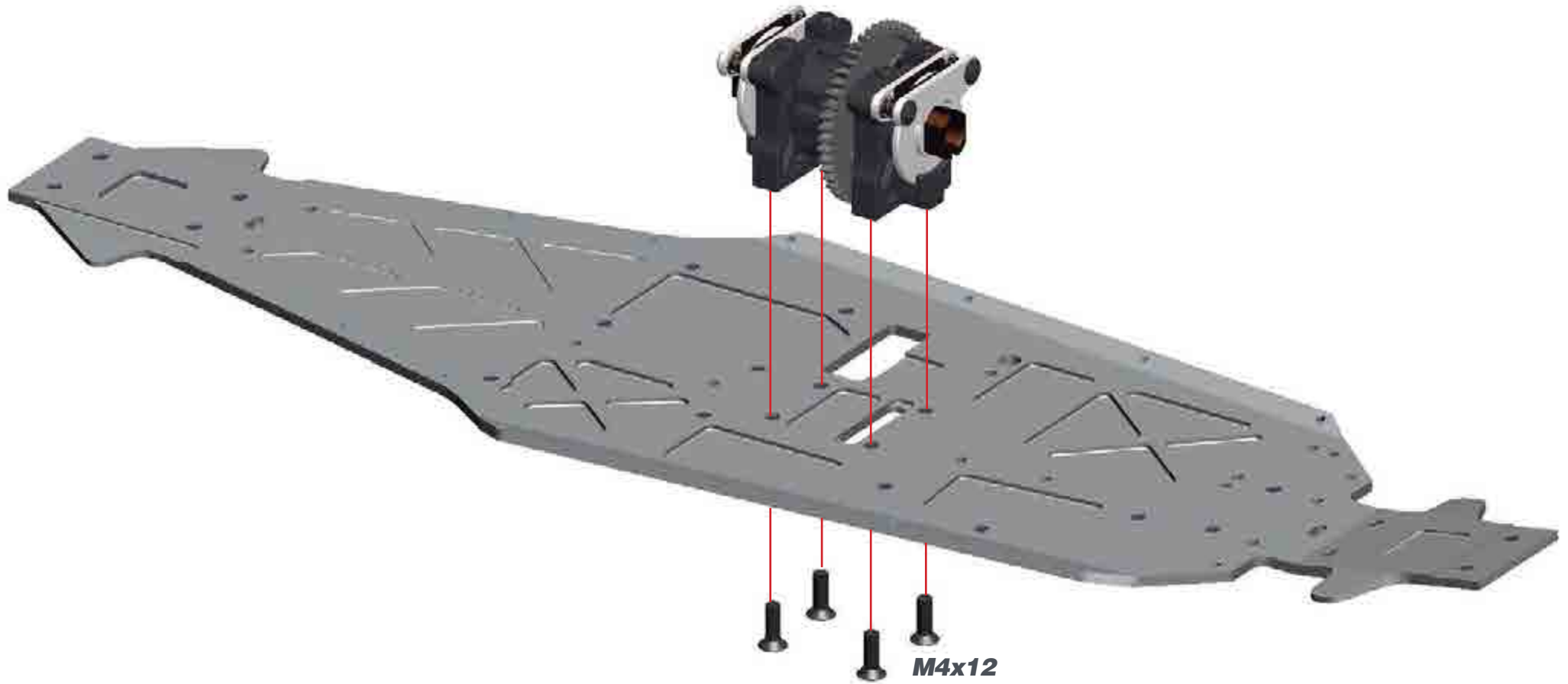

STEP 14

14.1

Nylock nut M3
3.2x7x0.5



M3x12

14.2

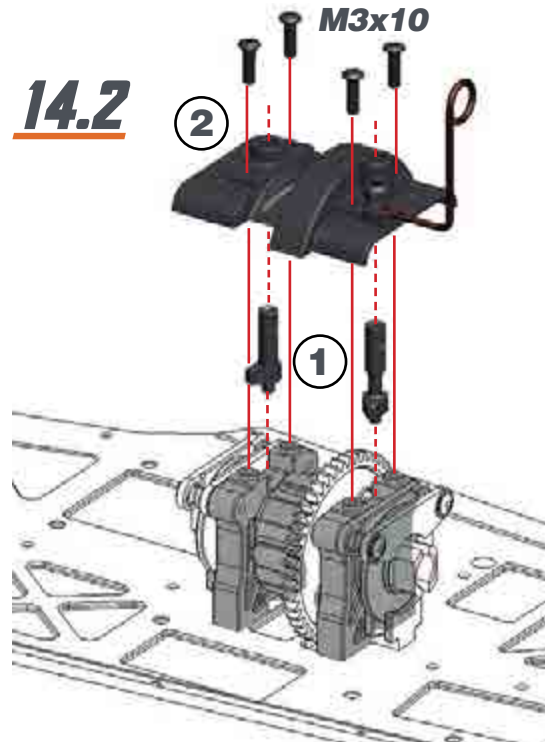

M3x10

2

1



BRAKE CAMS

The long cam is assembled in the front bracket, the short one in the rear bracket.

Rear Front

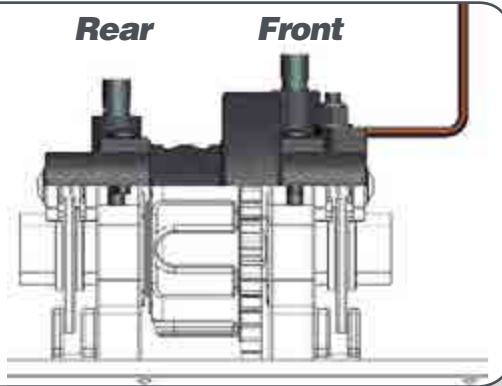

STEP 15

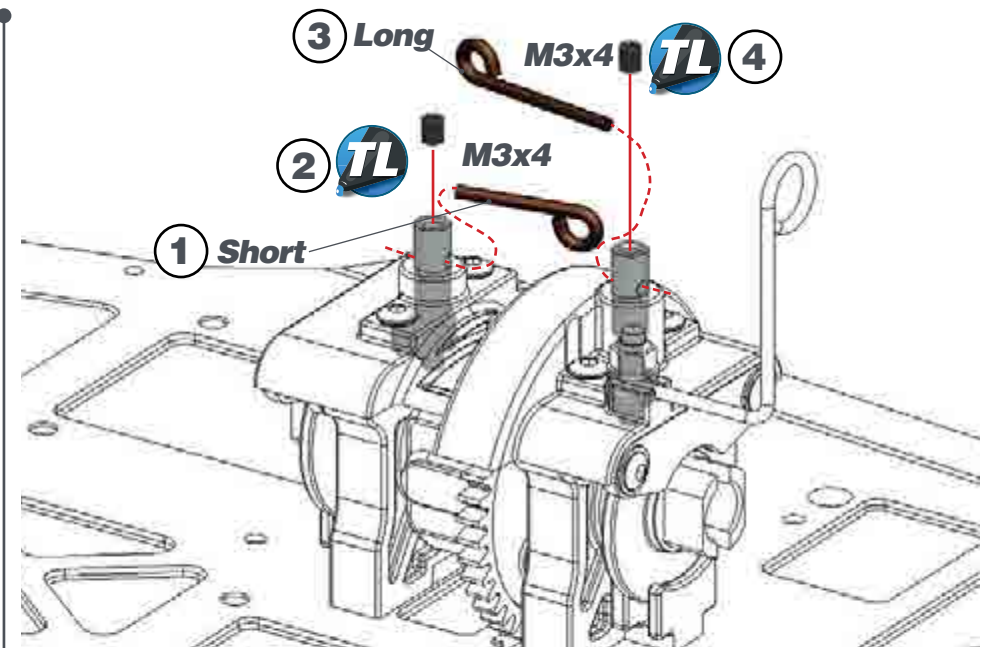

3 Long

M3x4

TL 4

2 TL

M3x4

1 Short



Note the correct brake wires position.

Rear

Front

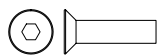
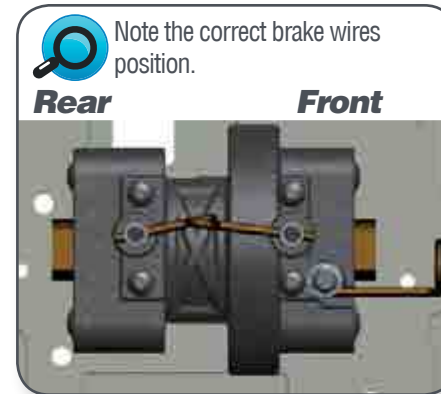

M3x12



3.2x7x0.5



Nylock Nut M3



M3x10



M3x4

STEP 16 BAG 2



! After building the differential with new gears, new differential case and bearings, the diff may feel a little tight. The connected parts need at least an hour run-time to create a perfect match. Attention: When you assemble the diff with too much initial play, the gears will not run-in properly and may wear quickly. After 1 or 2 hours of running the car, re-check the gear-mesh between the ring gear and the pinion. All parts should have run-in properly now. You may add or remove 8x11x0.1 shims as needed.

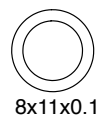
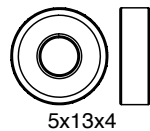
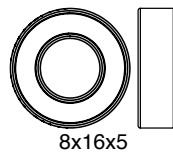

STEP 17

17.1

! After 1 or 2 hours of running the car, re-check the gear-mesh between the ring gear and the pinion. All parts should have run-in properly. You may add or remove 13x16x0.1 shims as needed.

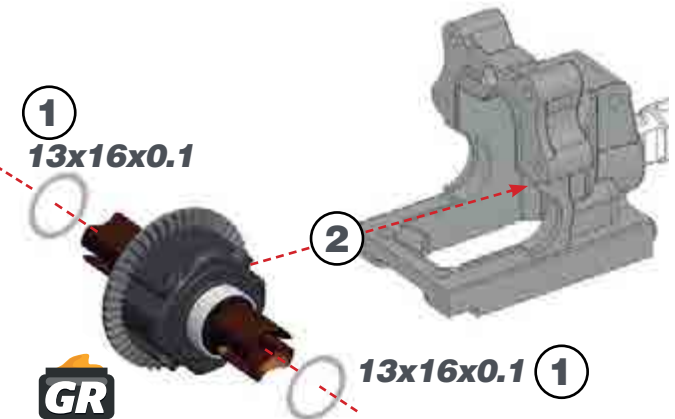

17.2

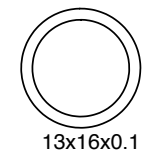
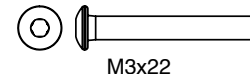
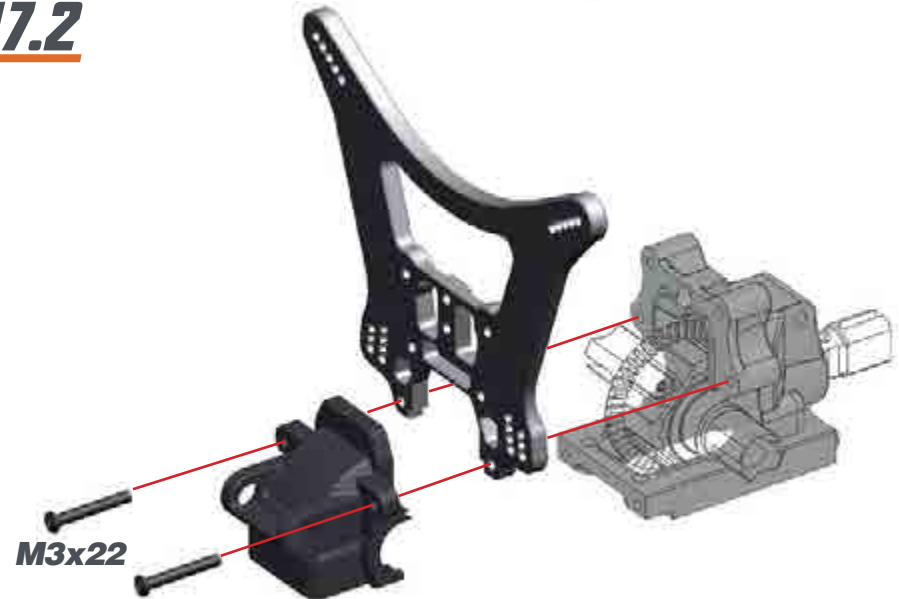

STEP 18

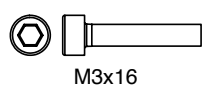
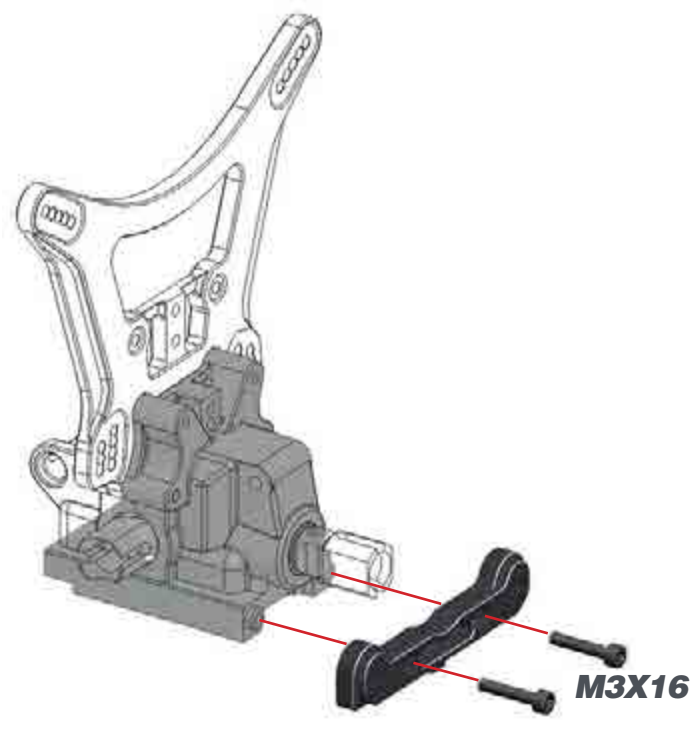

STEP 19 BAG 3

19.1

L=R

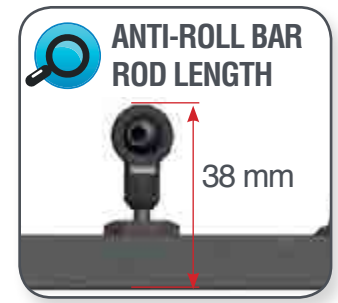

19.2

M2.5X6

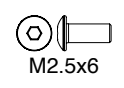

STEP 28

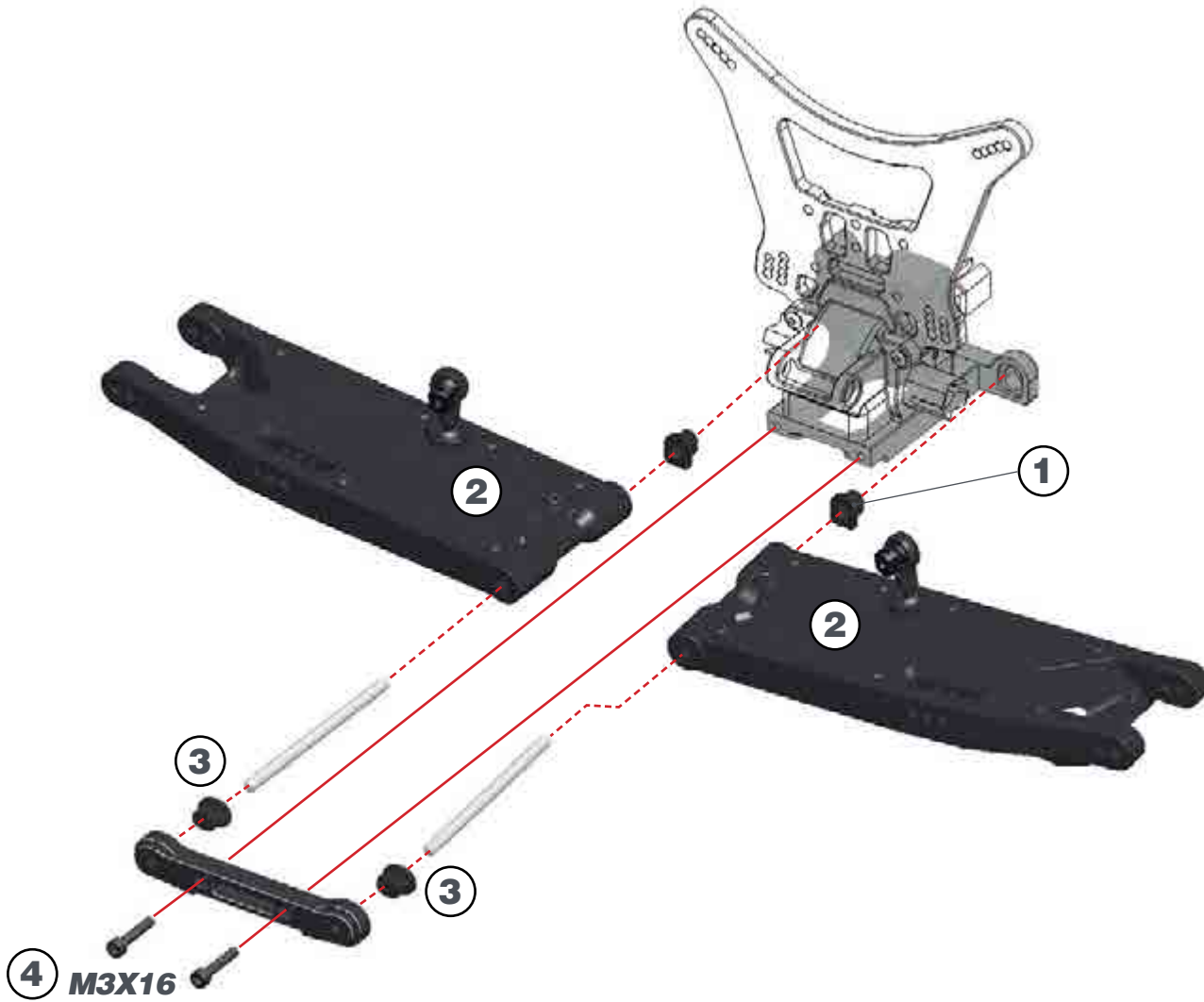

L=R REAR ANTI-SQUAT INSERTS CHART

1	1.5	2	2.5	3
<input checked="" type="radio"/>	<input checked="" type="radio"/>	<input checked="" type="radio"/>	<input checked="" type="radio"/>	<input checked="" type="radio"/>
DEF. SETUP				

L=R REAR TOE IN INSERTS CHART

2	2.5	2.75	3	3.25	3.5	4
<input checked="" type="radio"/>	<input checked="" type="radio"/>	<input checked="" type="radio"/>	<input checked="" type="radio"/>	<input checked="" type="radio"/>	<input checked="" type="radio"/>	<input checked="" type="radio"/>
DEF. SETUP						

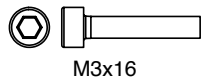

STEP 22

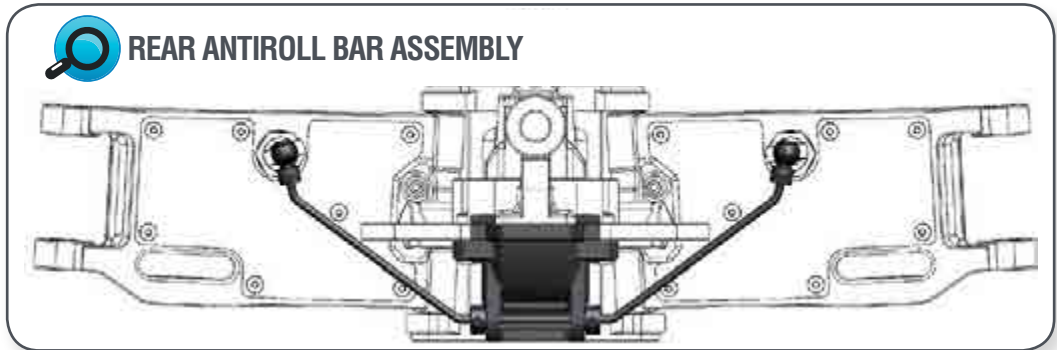
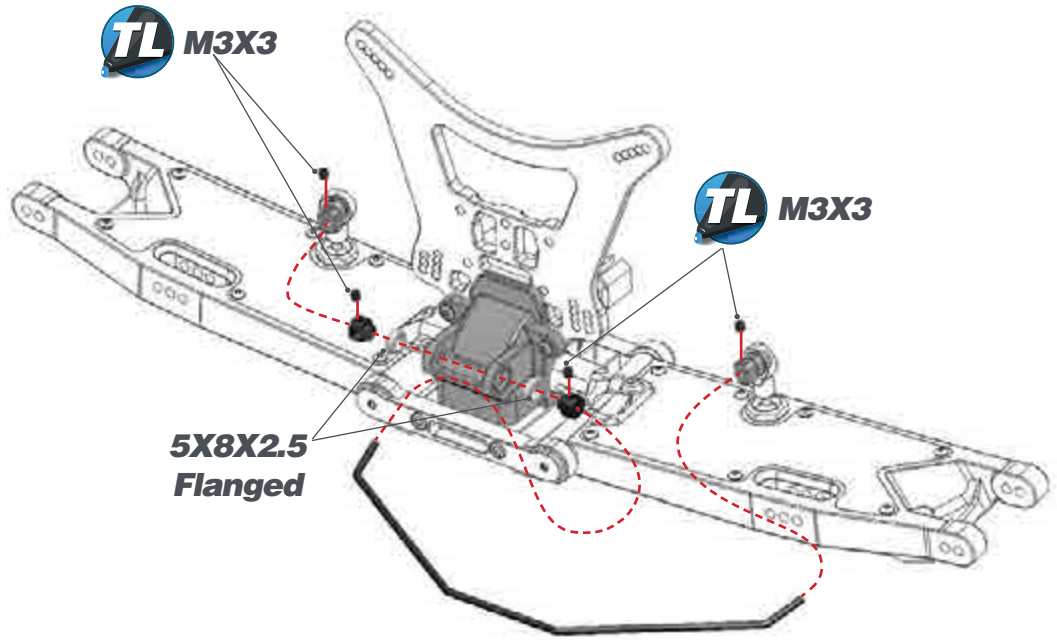

- 5X8X2.5 Flanged
- M3x3

STEP 23

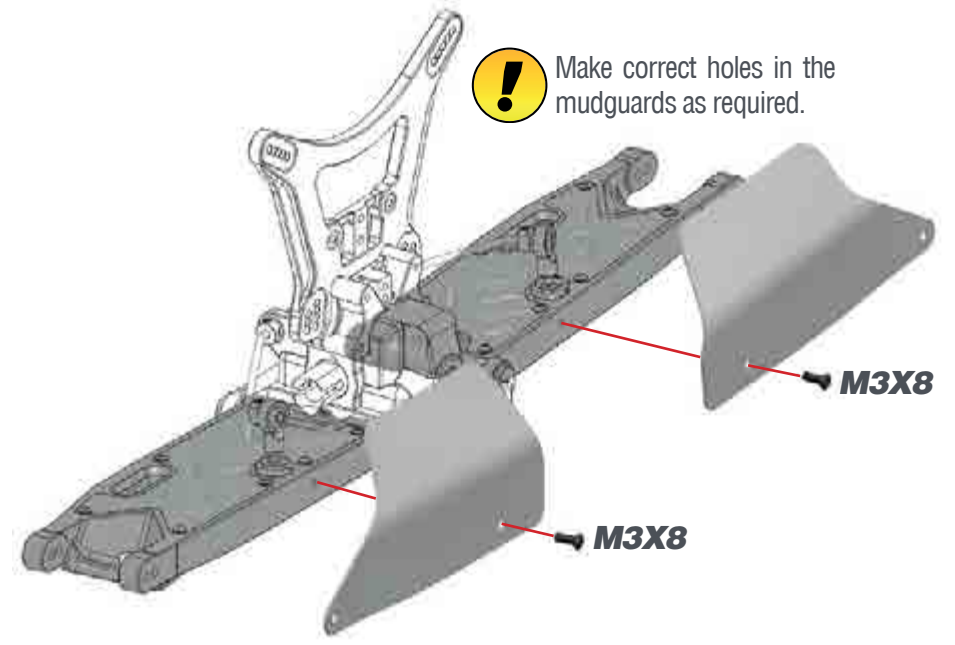

- M3x8

STEP 24 BAG 4

24.1 L=R

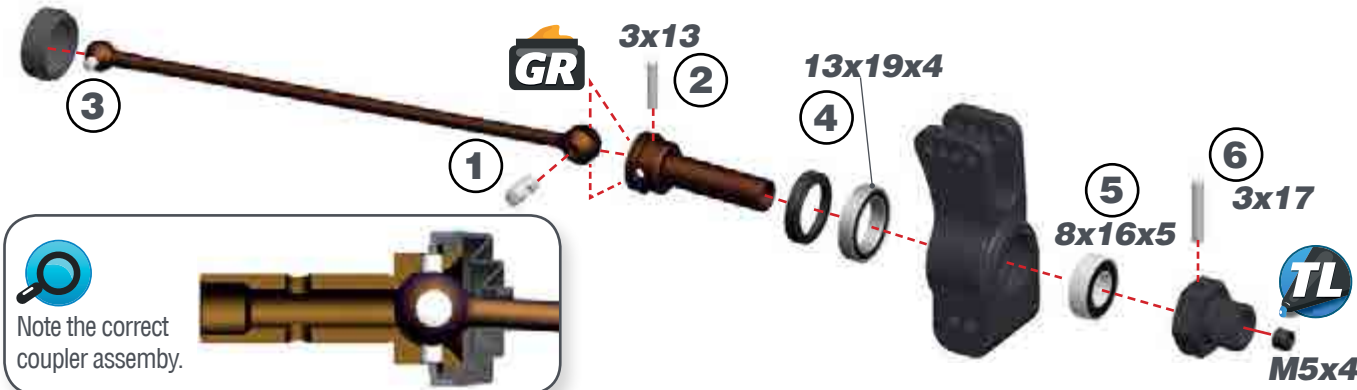

24.2

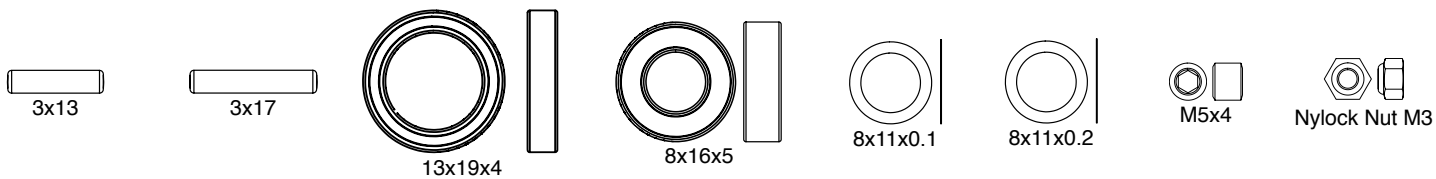
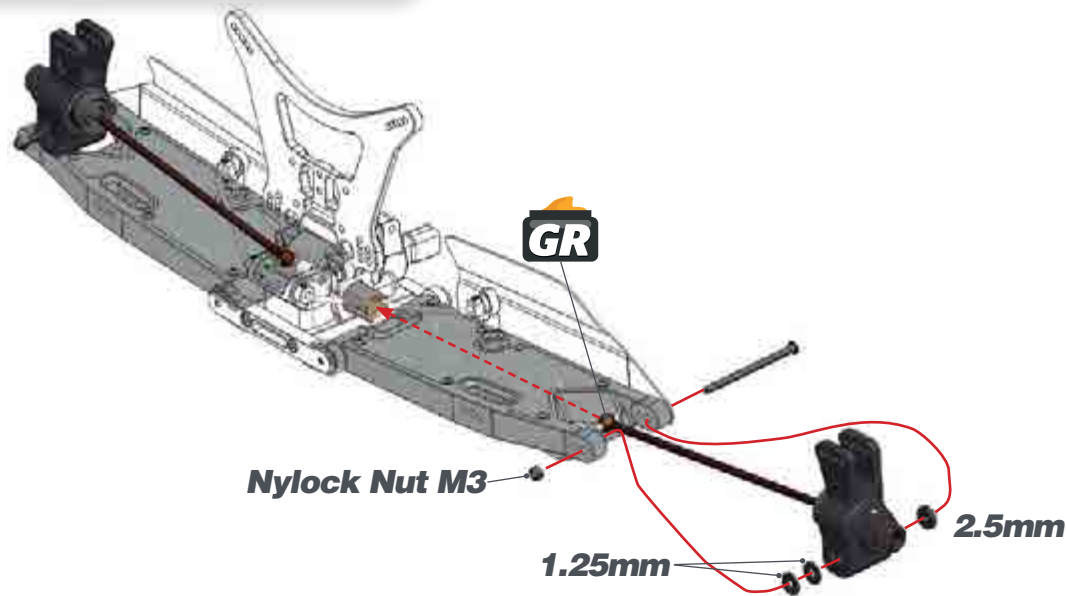

STEP 25 BAG 5

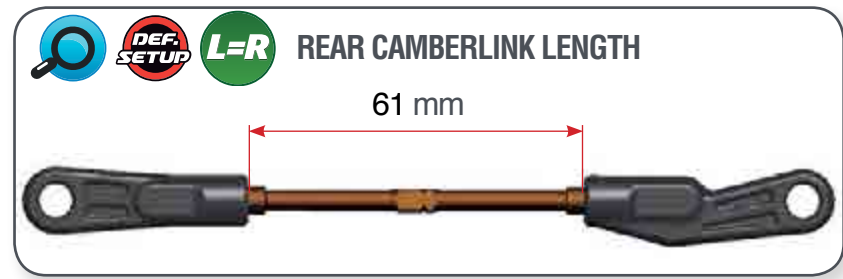

25.2

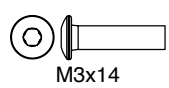
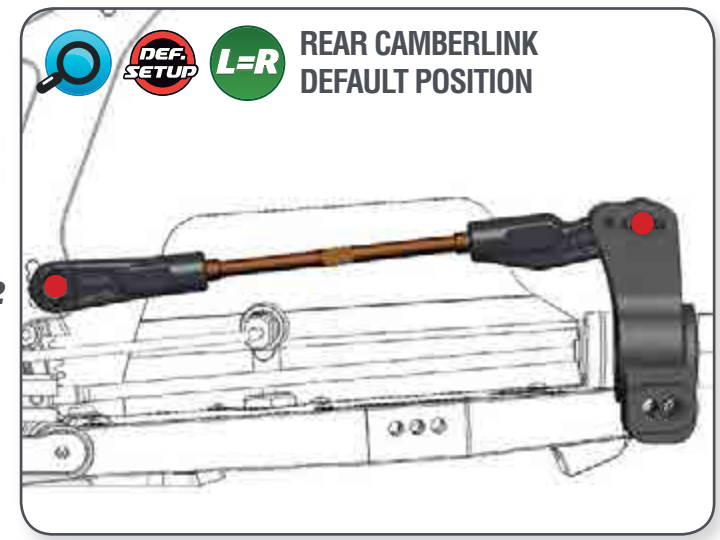
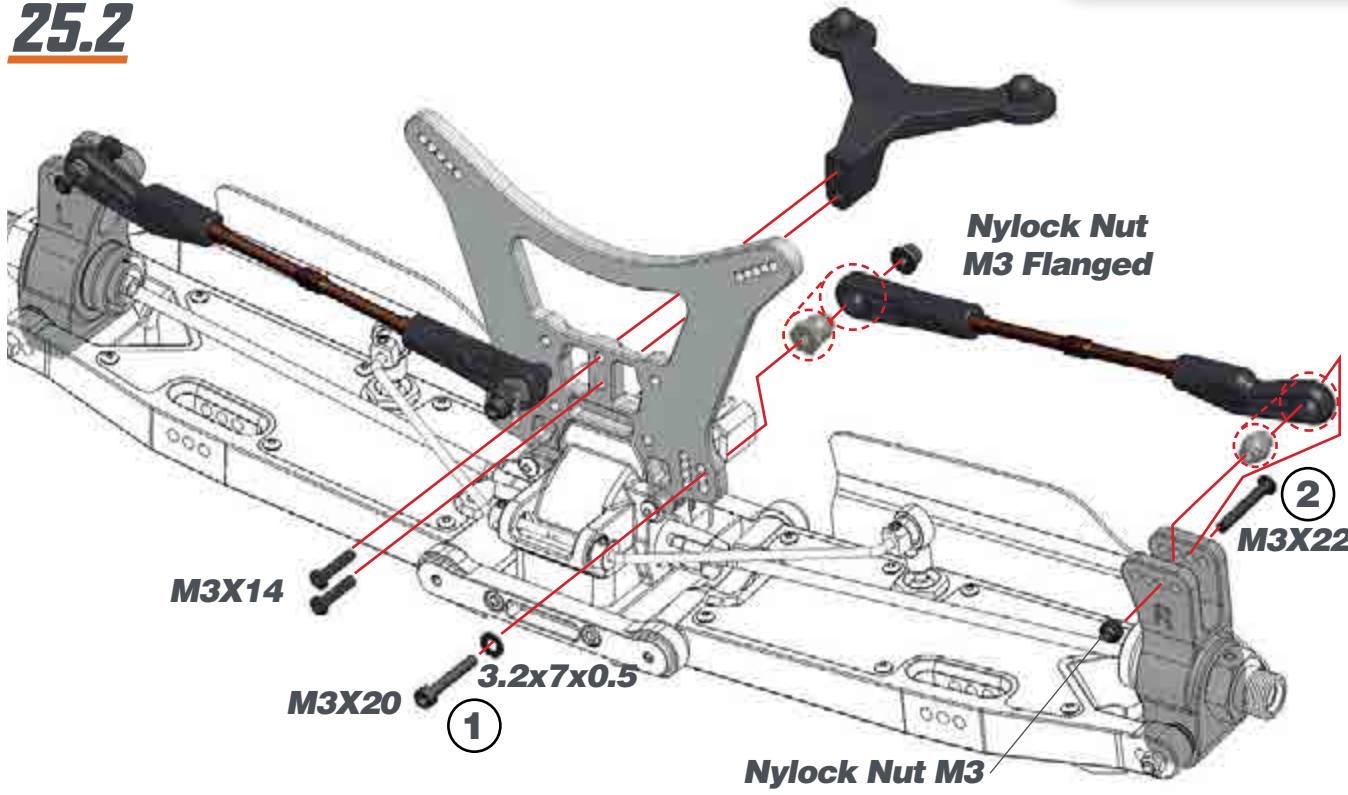

M3x14

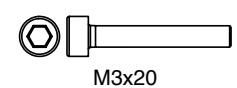

M3x20



3.5x7x0.5



Nylock Nut M3 Flanged

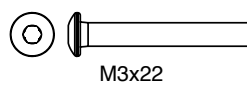

M3x22



Nylock Nut M3

STEP 26

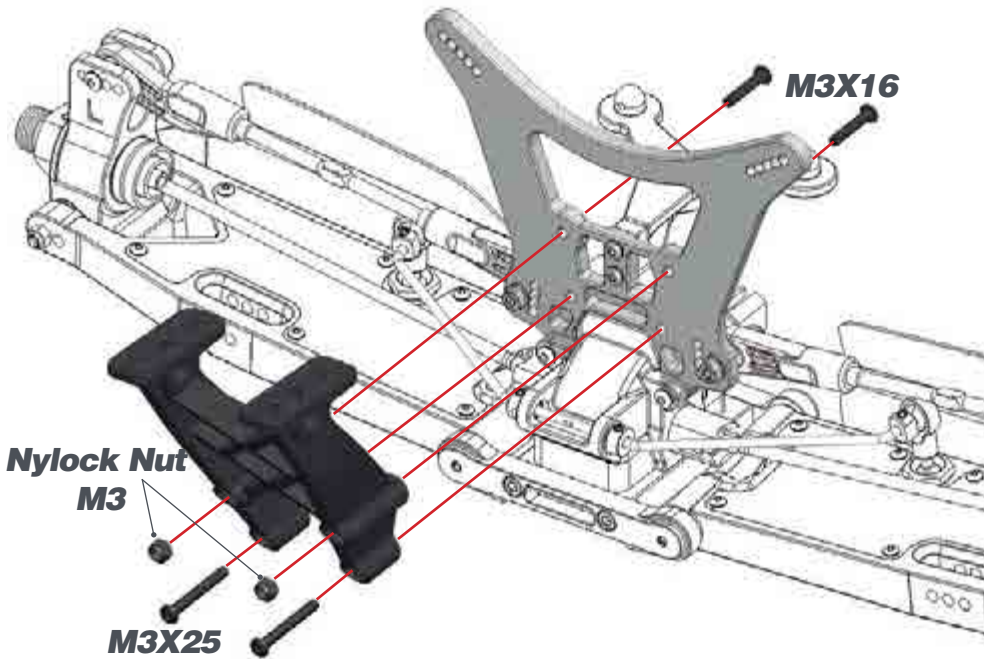

STEP 27

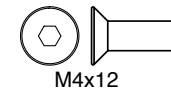
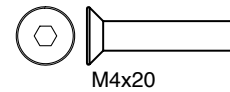
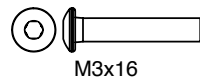
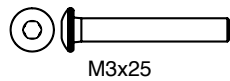
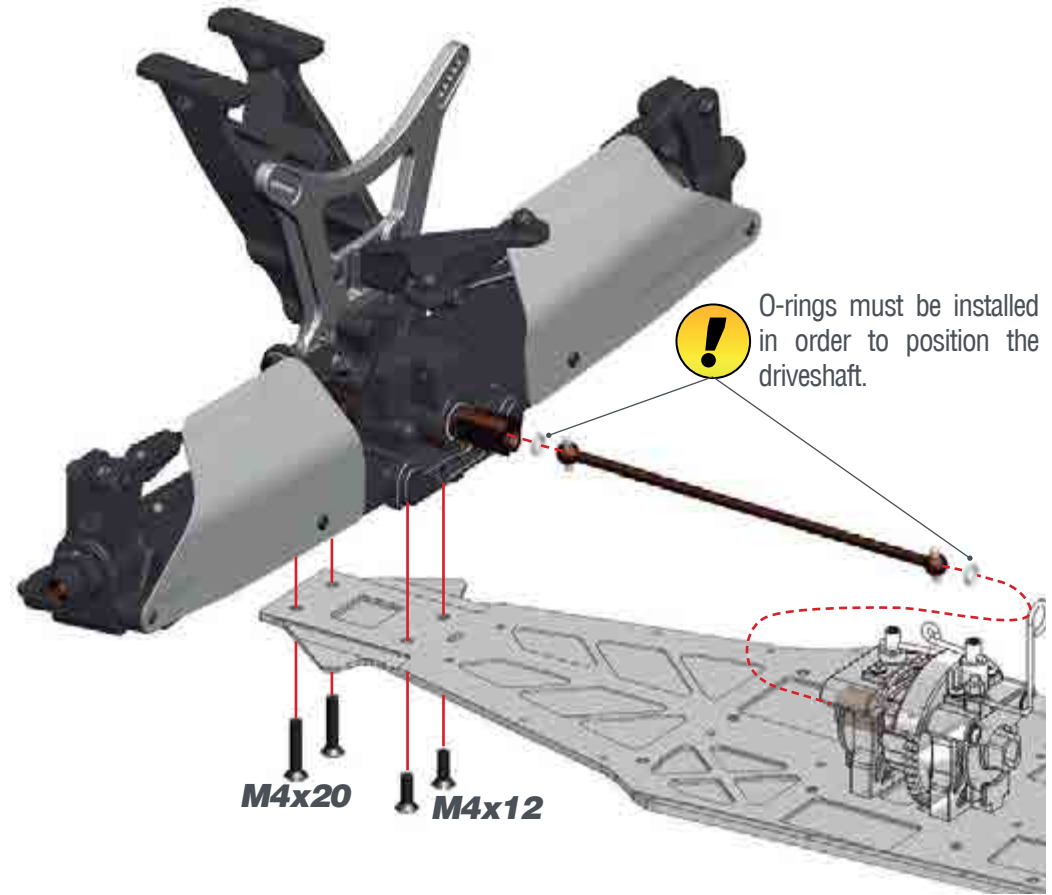

STEP 28

BAG 6





After building the differential with new gears, new differential case and bearings, the diff may feel a little tight. The connected parts need at least an hour run-time to create a perfect match. Attention: When you assemble the diff with too much initial play, the gears will not run-in properly and may wear quickly. After 1 or 2 hours of running the car, re-check the gear-mesh between the ring gear and the pinion. All parts should have run-in properly now. You may add or remove 8x11x0.1 shims as needed.





M5x4

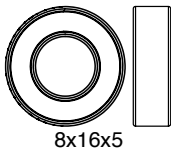

8x16x5

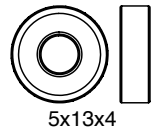

5x13x4

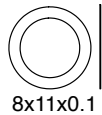

8x11x0.1

STEP 29

29.1

! After 1 or 2 hours of running the car, re-check the gear-mesh between the ring gear and the pinion. All parts should have run-in properly. You may add or remove 13x16x0.1 shims as needed.

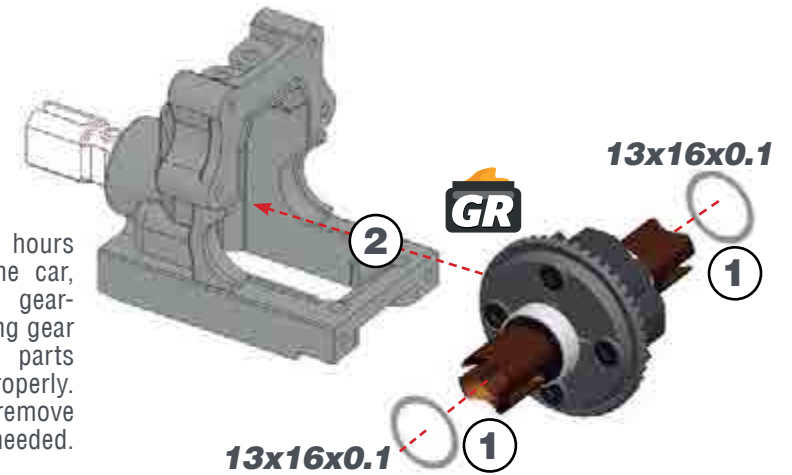

29.2

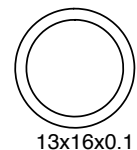

13x16x0.1

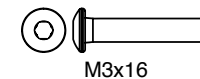

M3x16

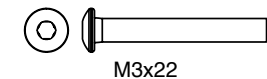

M3x22

STEP 30

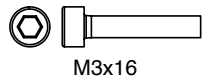
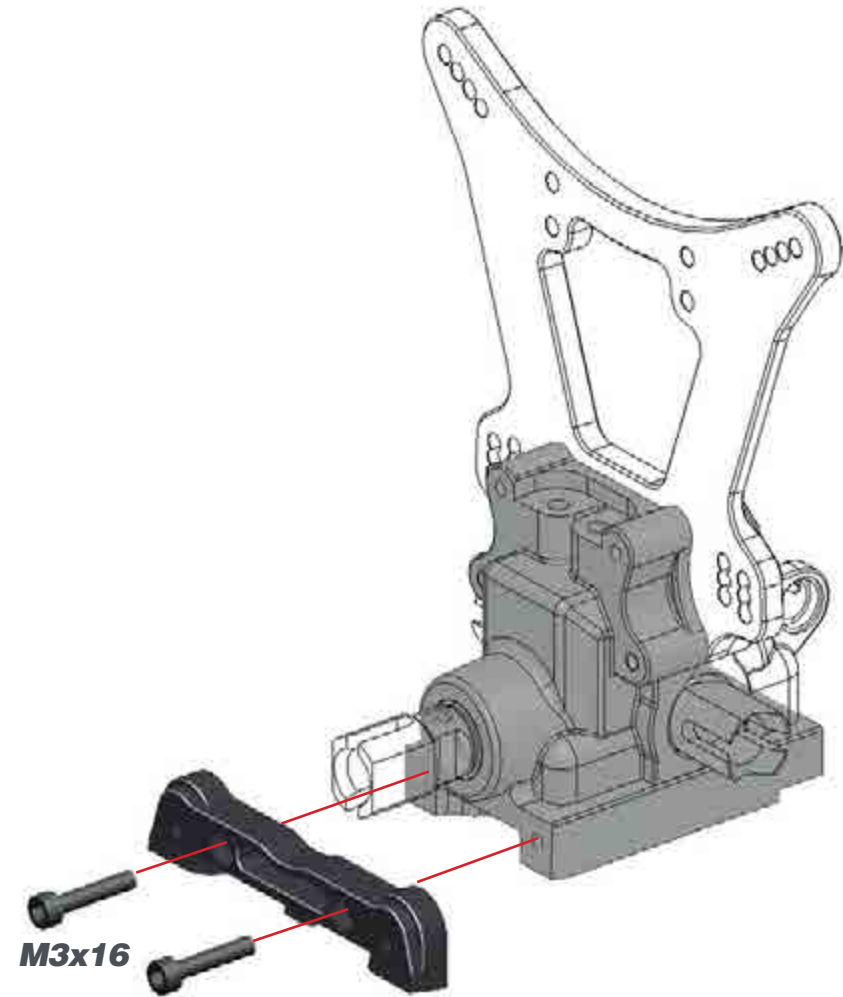

STEP 31 BAG 7

31.1

L=R ! Tighten anti-roll bar cap until there is no play, and it moves freely.



31.2

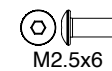

STEP 32

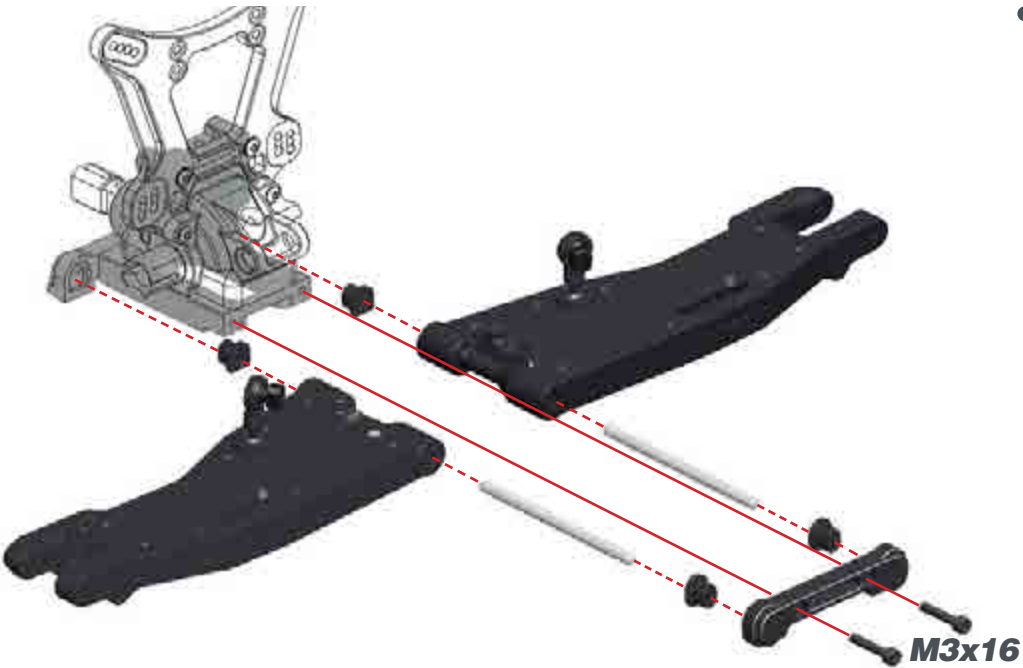

L=R FRONT REAR INSERTS

0	1	2
●	●	●

DEF. SETUP

L=R FRONT SUSPENSION KICKUP INSERTS

9	9.5	10	10.5	11
●	●	●	●	●

DEF. SETUP

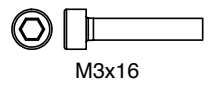

STEP 33

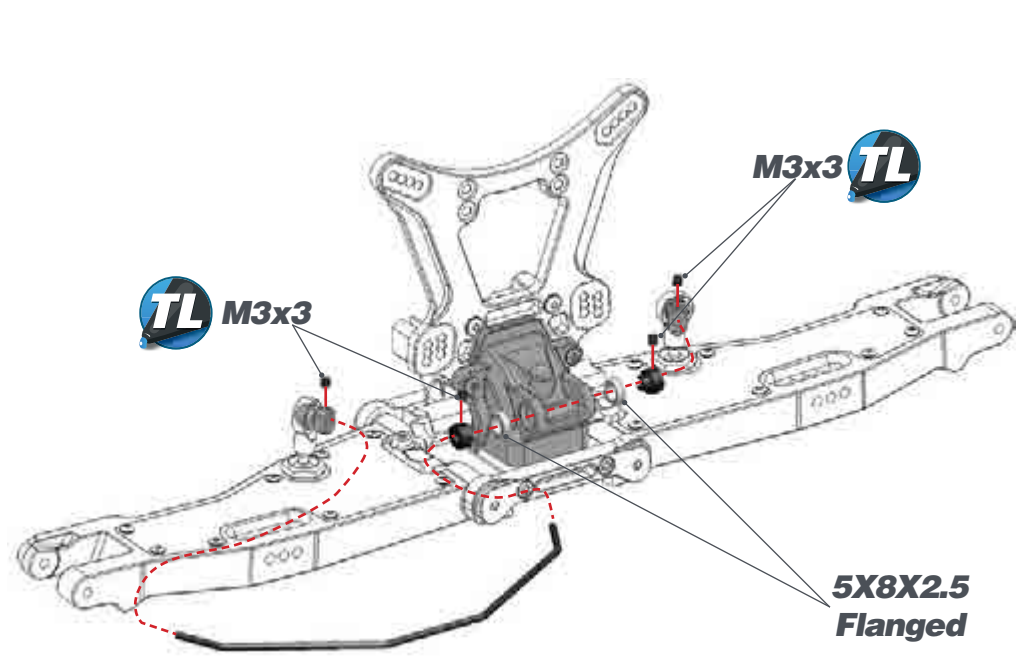

FRONT ANTIROLL BAR ASSEMBLY



STEP 34 BAG 8

34.1 **L=R**

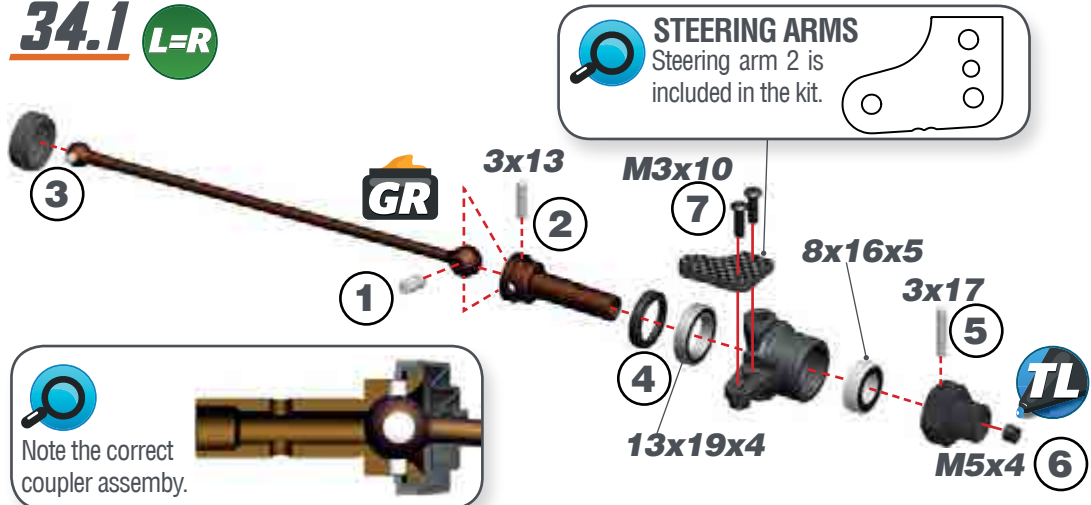



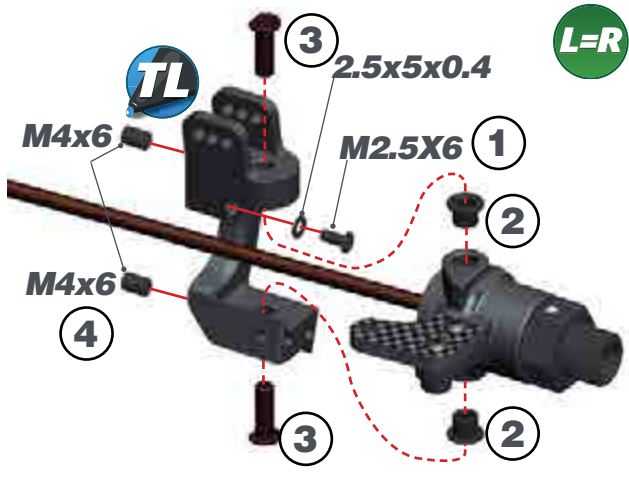

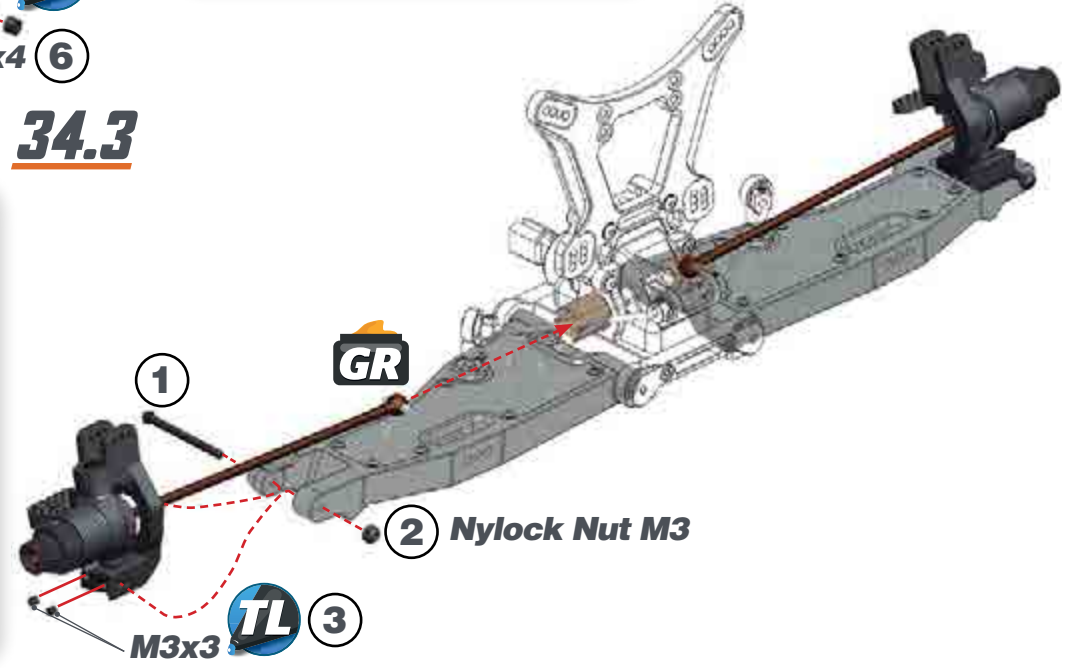

34.2

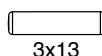
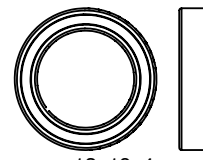
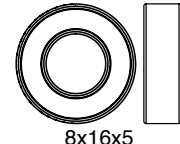
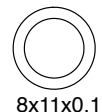
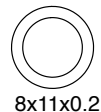
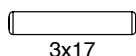

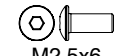
34.3



-  3x13
-  13x19x4
-  8x16x5
-  8x11x0.1
-  8x11x0.2
-  3x17
-  M5x4
-  M3x10
-  M2.5x6
-  2.5x5x0.4
-  M4x6
-  M3x3
-  Nylock Nut M3

STEP 35 BAG 9

35.1

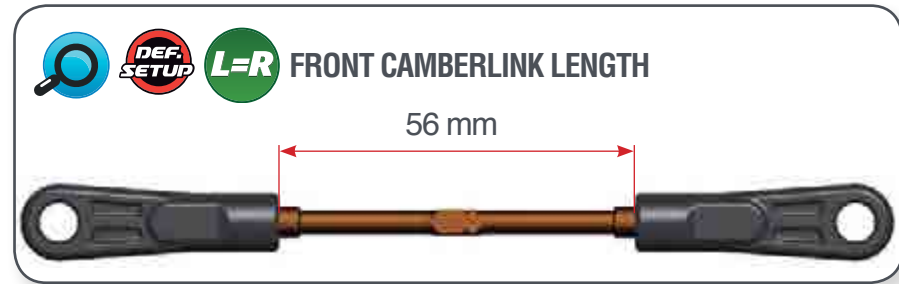

35.2

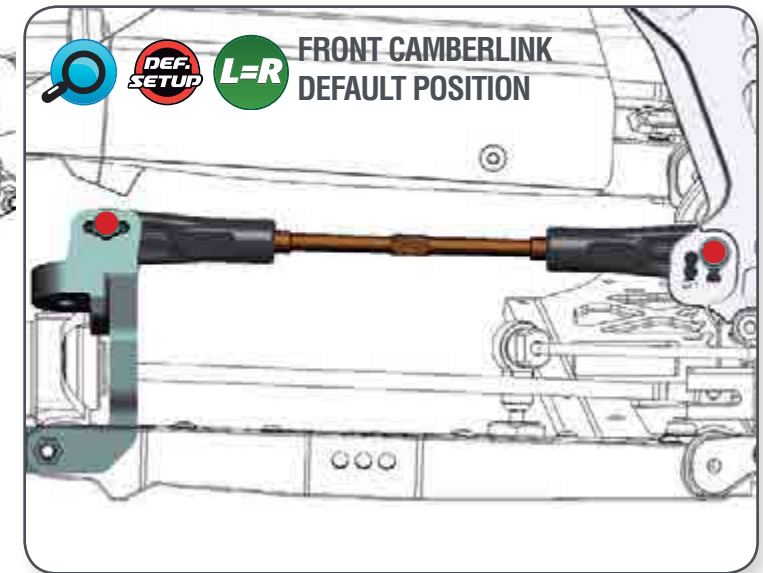
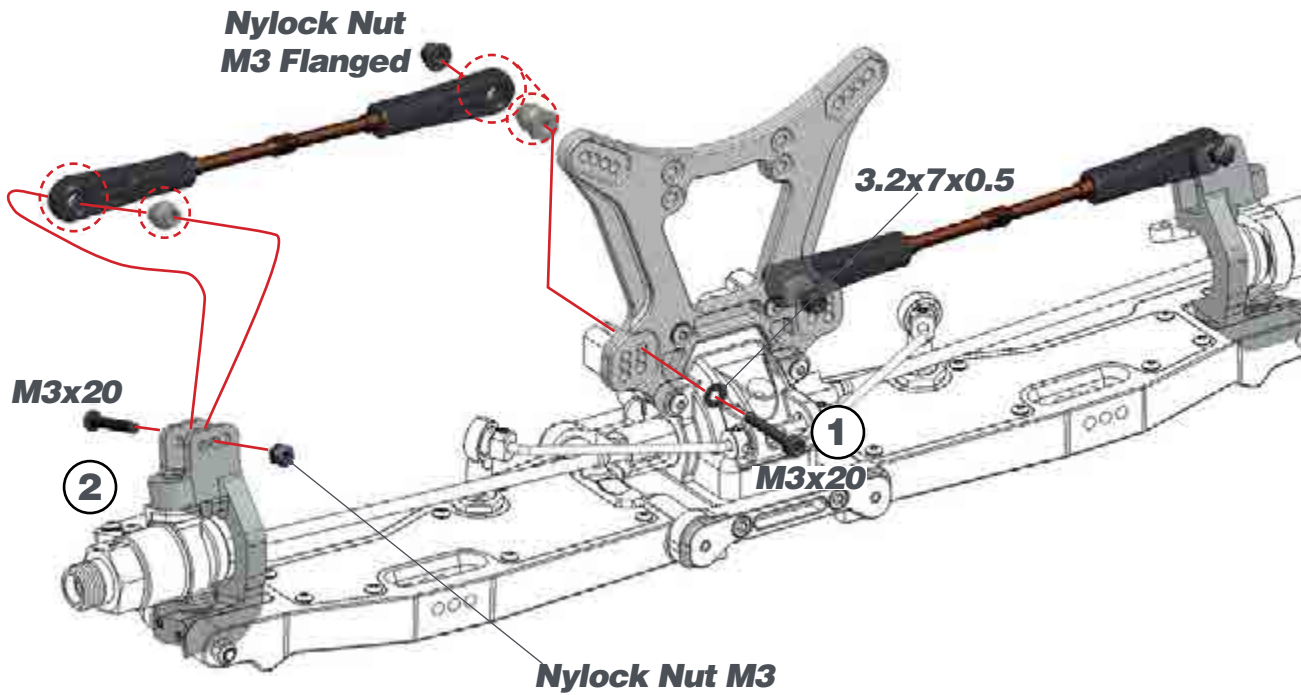

STEP 36

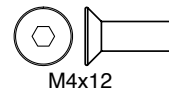
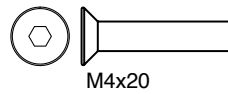
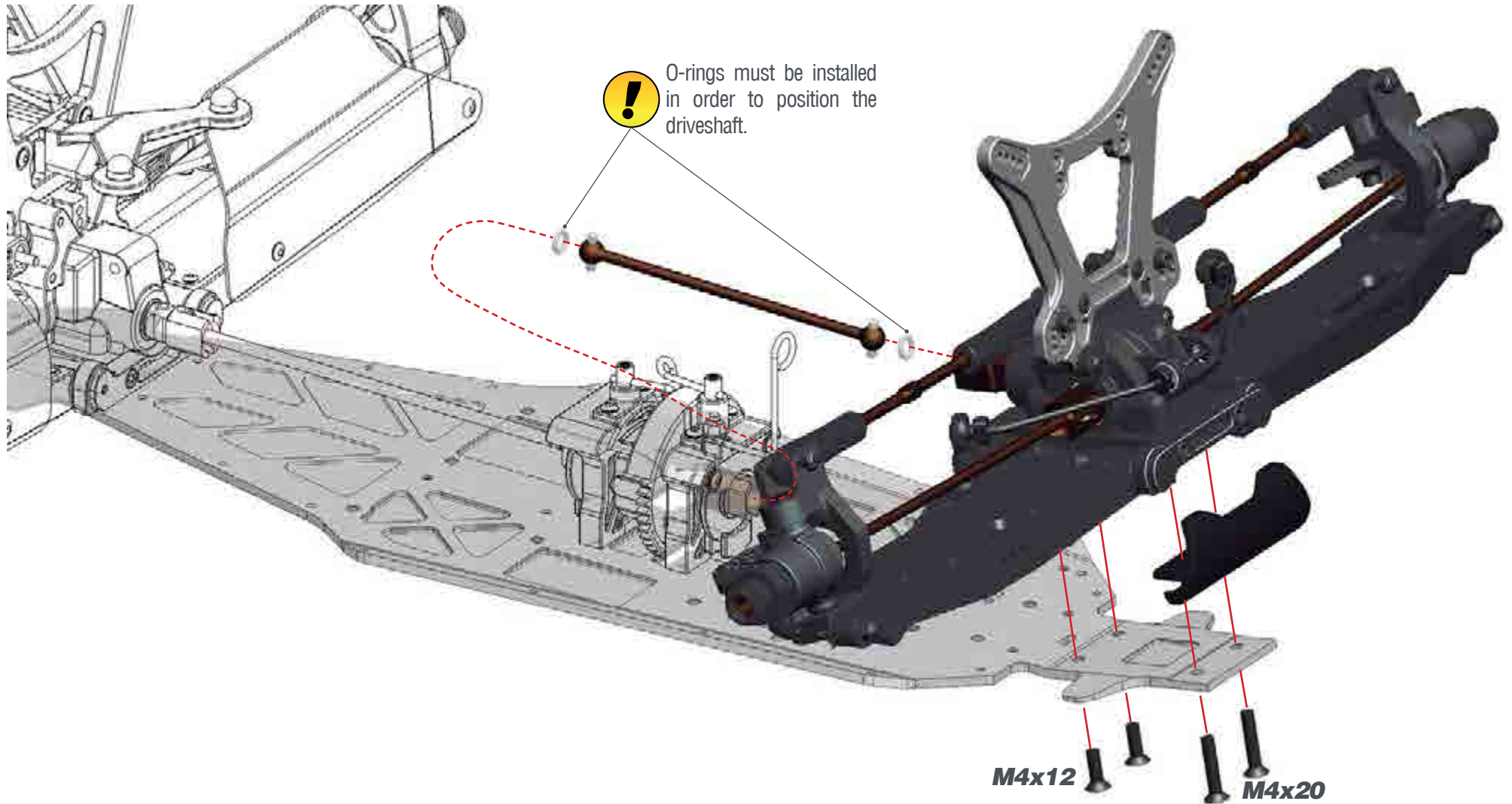

STEP 37

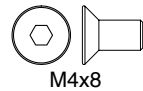
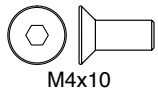
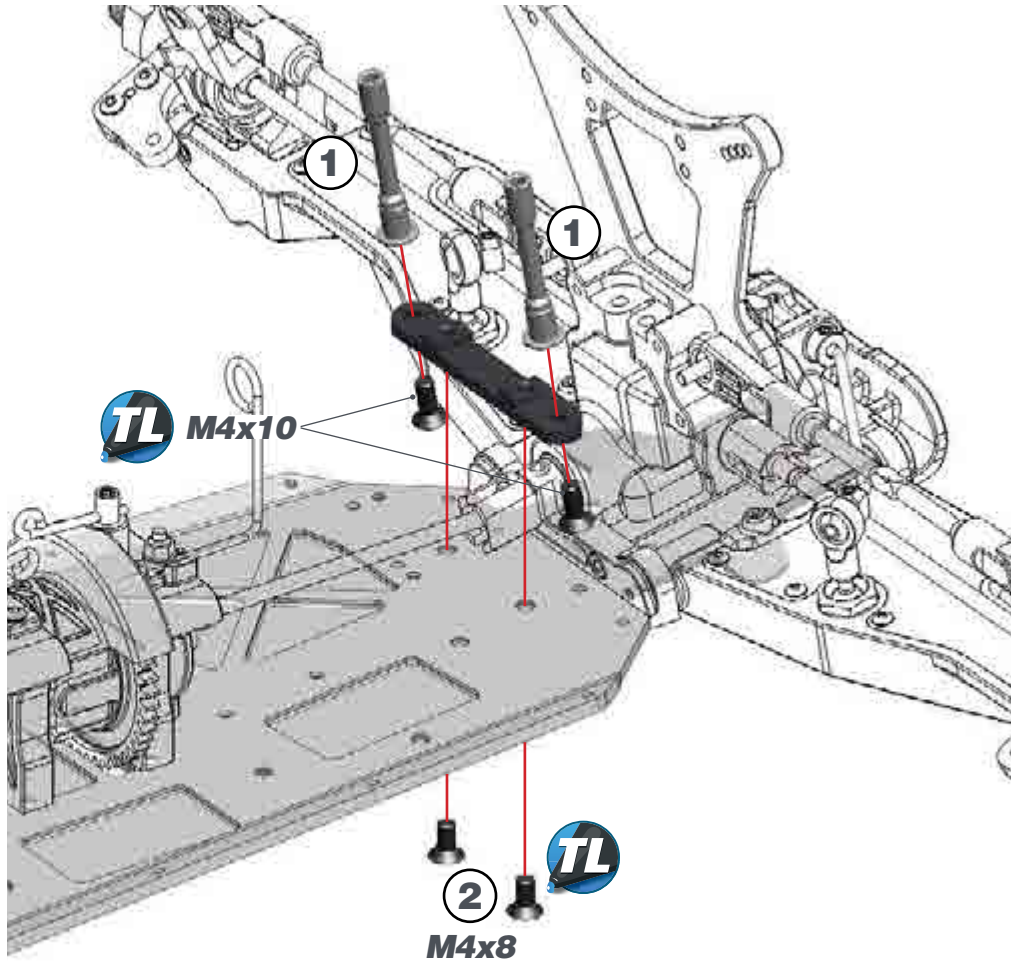

STEP 38 BAG 10

38.1



M2x10

38.2

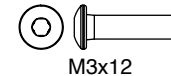
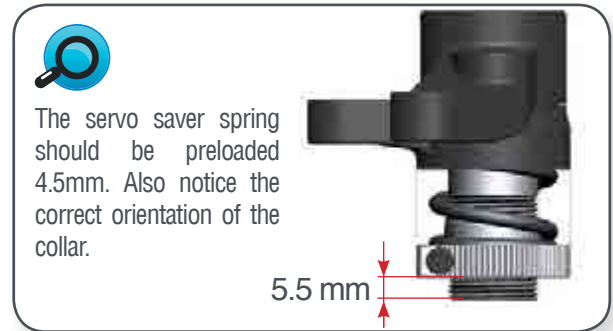

STEP 39

39.1



STEERING TRACKROD LENGTH

52.5 mm



39.2

Nylock Nut M3

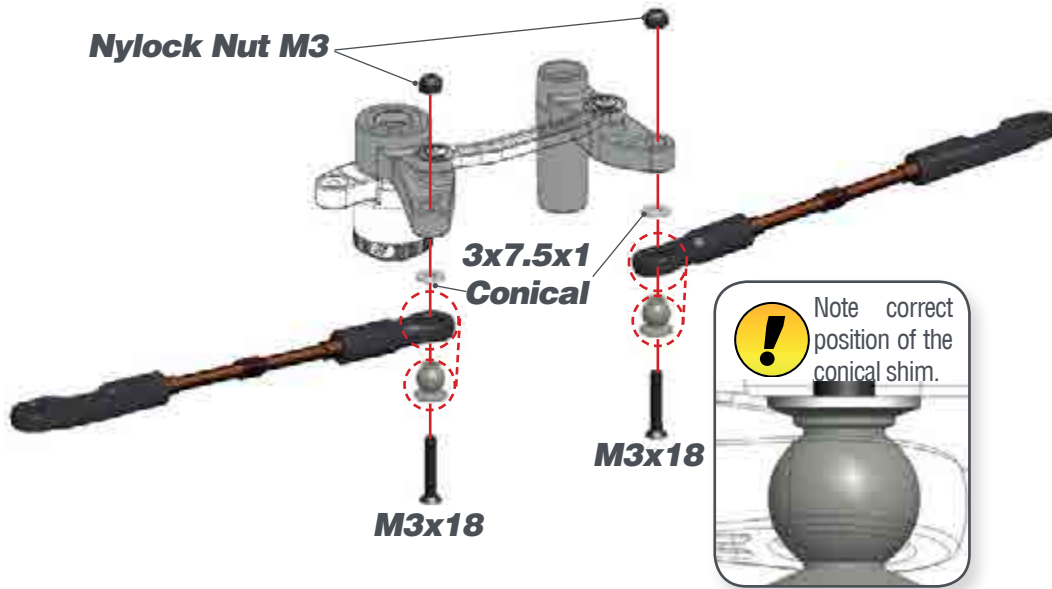

3x7.5x1 Conical

M3x18

M3x18

Note correct position of the conical shim.

STEP 40

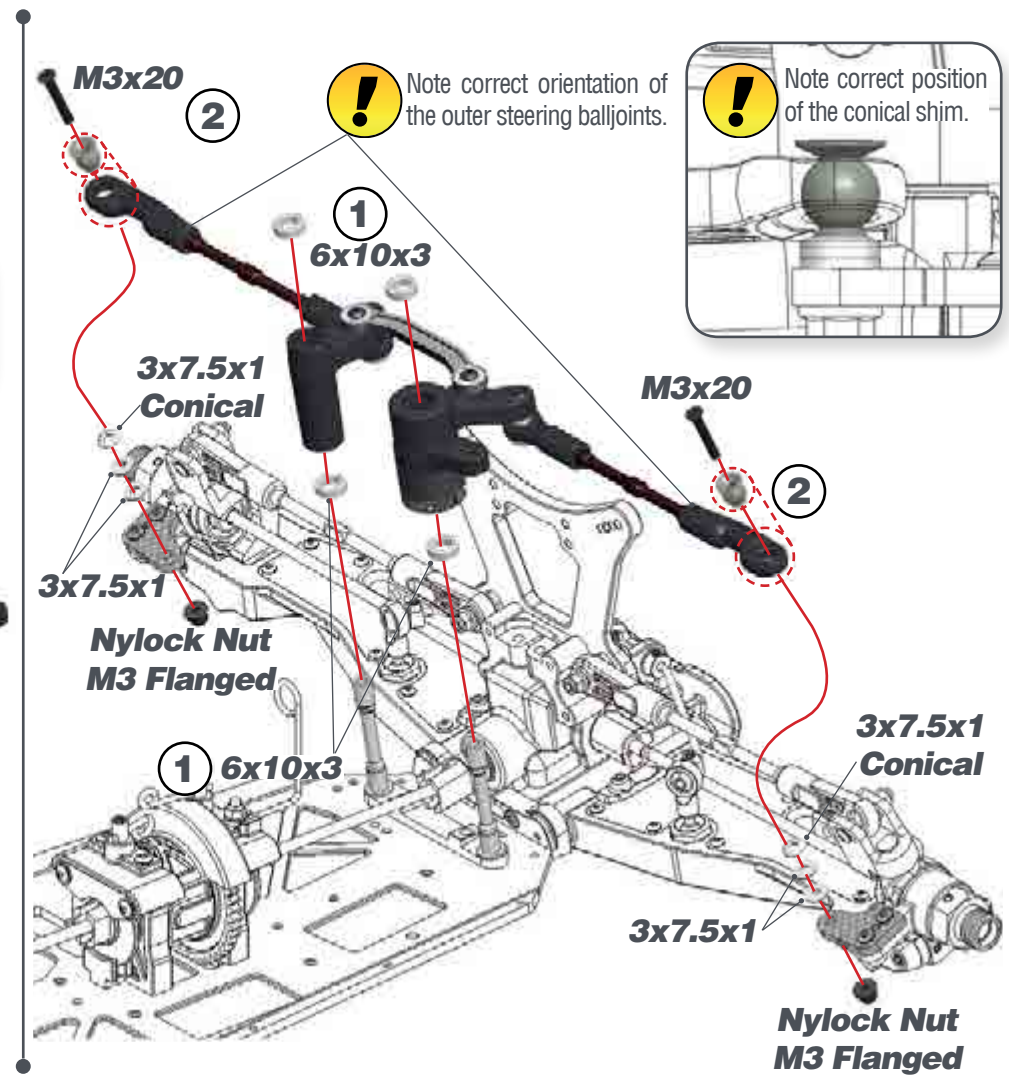

M3x20

2

Note correct orientation of the outer steering balljoints.

Note correct position of the conical shim.

1

6x10x3

3x7.5x1 Conical

M3x20

2

3x7.5x1

Nylock Nut M3 Flanged

1

6x10x3

3x7.5x1 Conical

3x7.5x1

Nylock Nut M3 Flanged

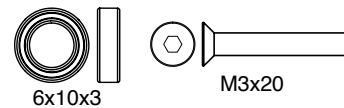
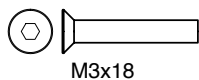

STEP 41 BAG 11

STEP 42

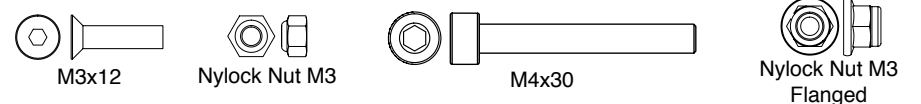
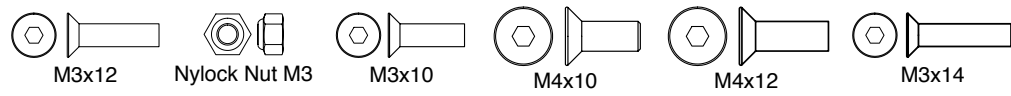
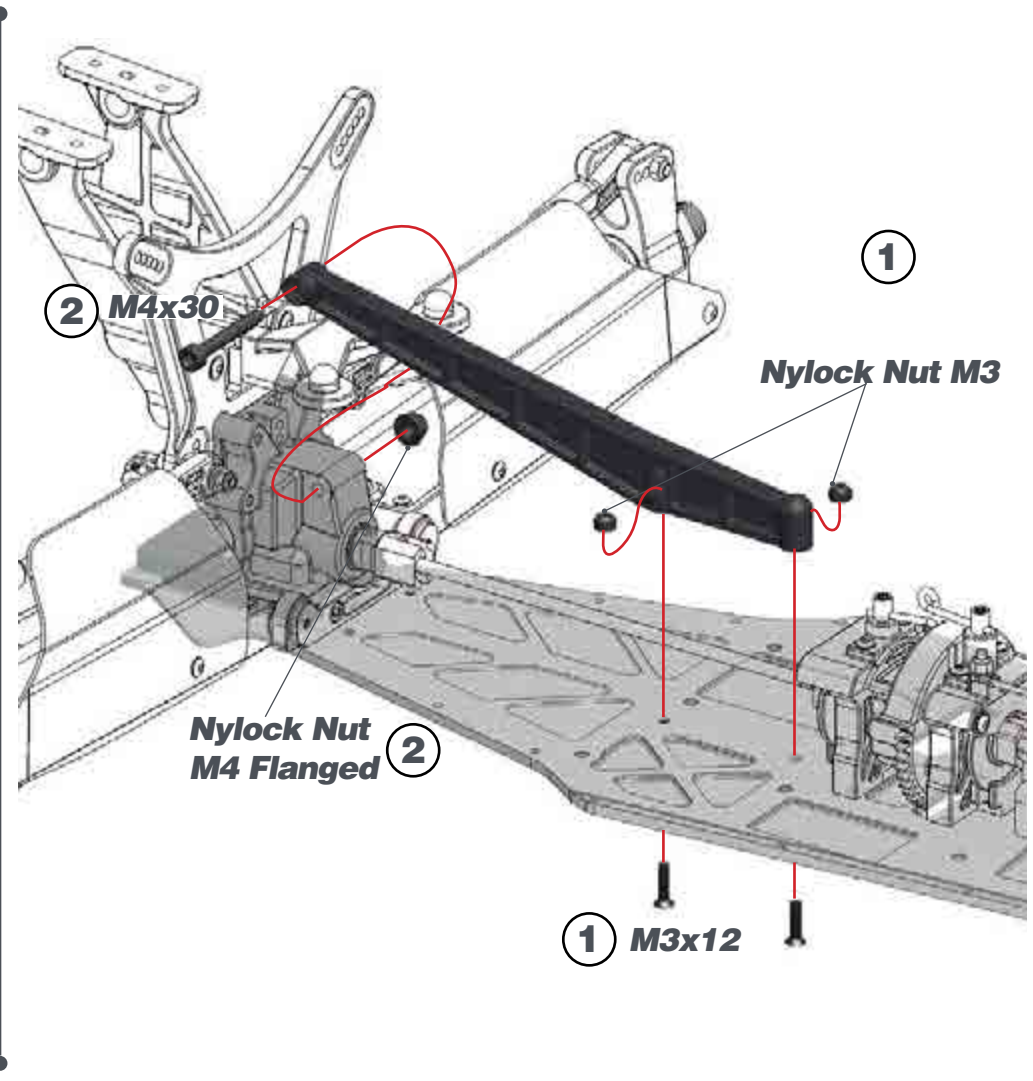
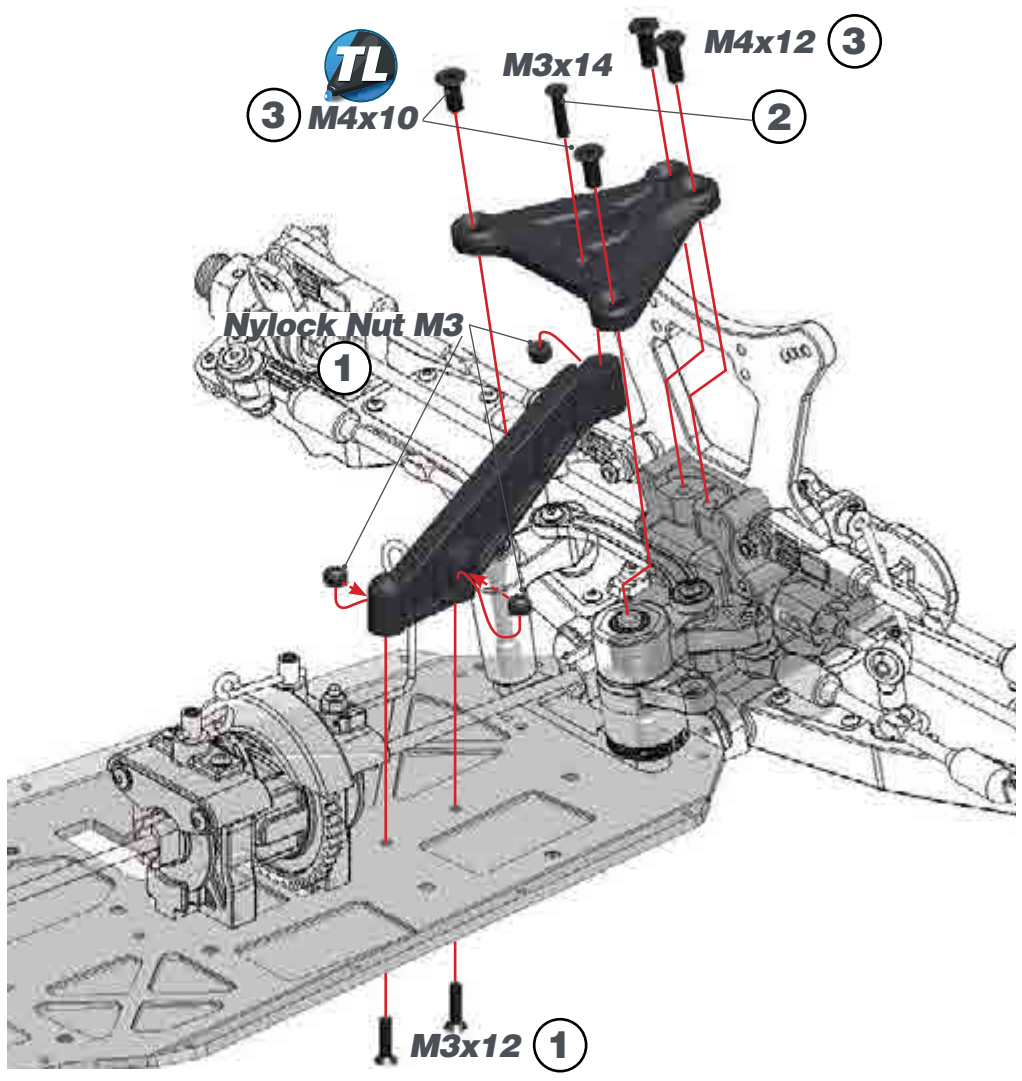

STEP 43

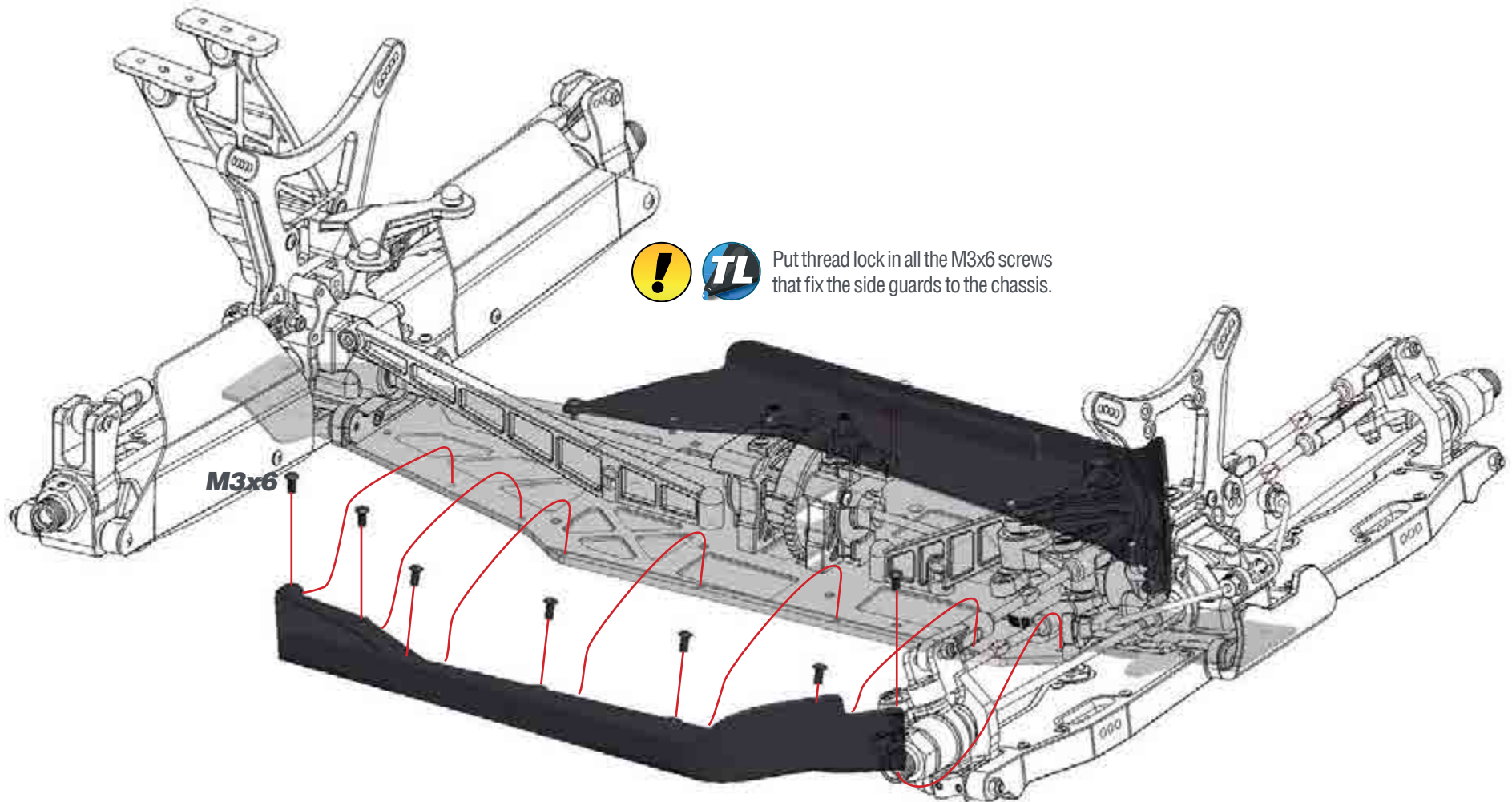

! **TL** Put thread lock in all the M3x6 screws that fix the side guards to the chassis.

M3x6

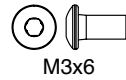

STEP 44 BAG 12

44.1



STEERING LINK LENGTH

Between different servo brands there could be slight differences.

19.3 - 19.6 mm



44.2

Nylock Nut M3

1

M3x8

2

3x7.5x1 Conical



Check how many teeth your servo spline has (23, 24 or 25) and use the right lever.



Note correct position of the conical shim.

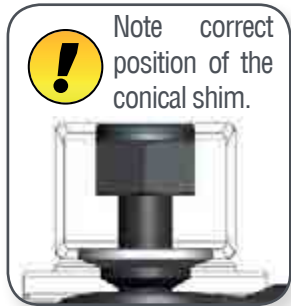

STEP 45

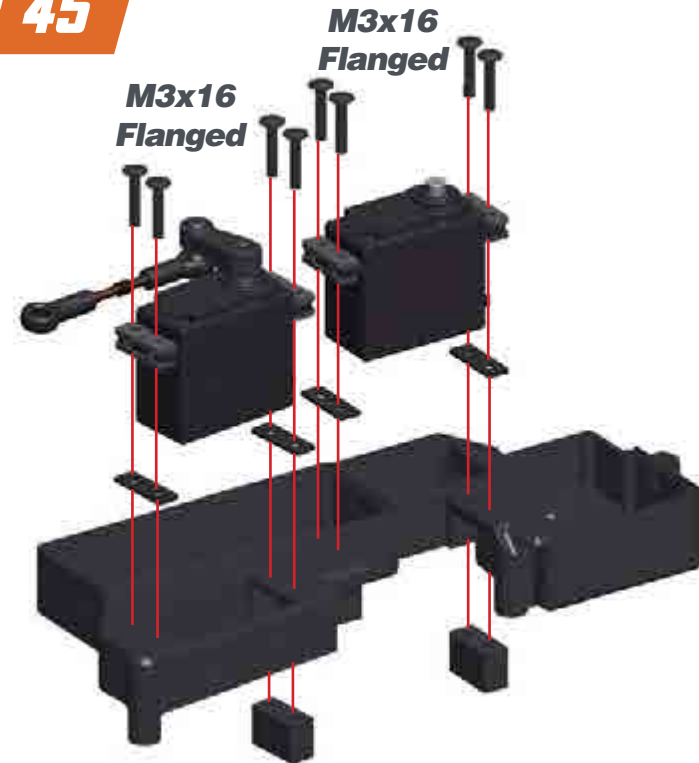

M3x16 Flanged

M3x16 Flanged



SERVO SPACERS

Use enough servo spacers so both servos are flush with the bottom of the radio tray posts. This will prevent the servo to touch the chassis under torsion – flex.

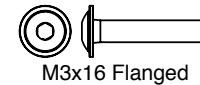

STEP 46

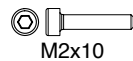
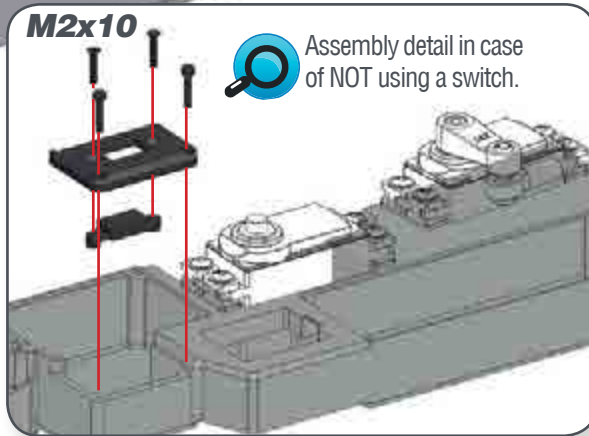
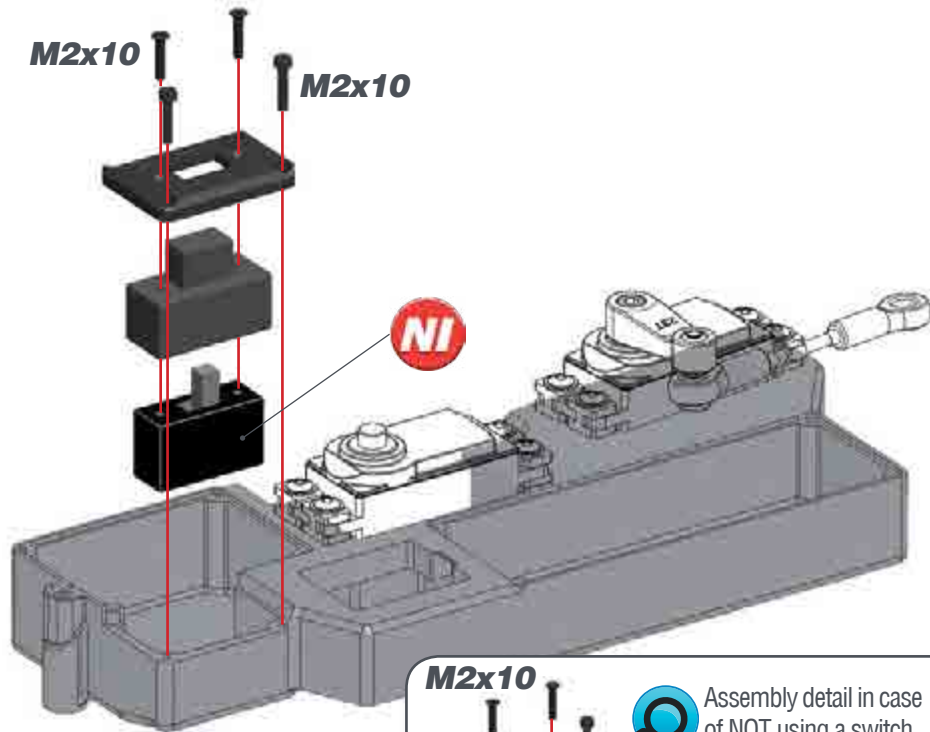

STEP 47

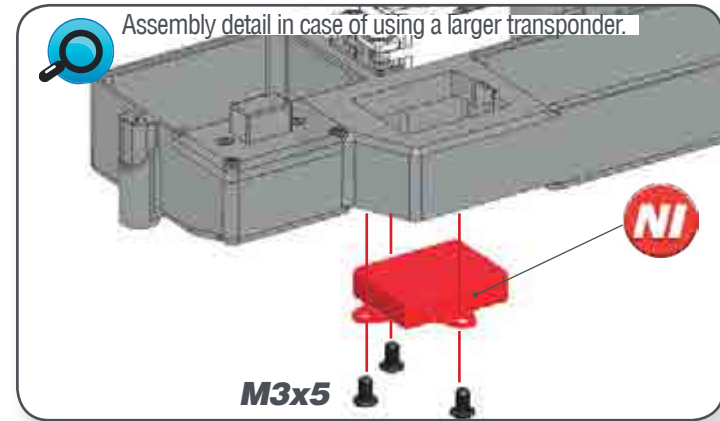
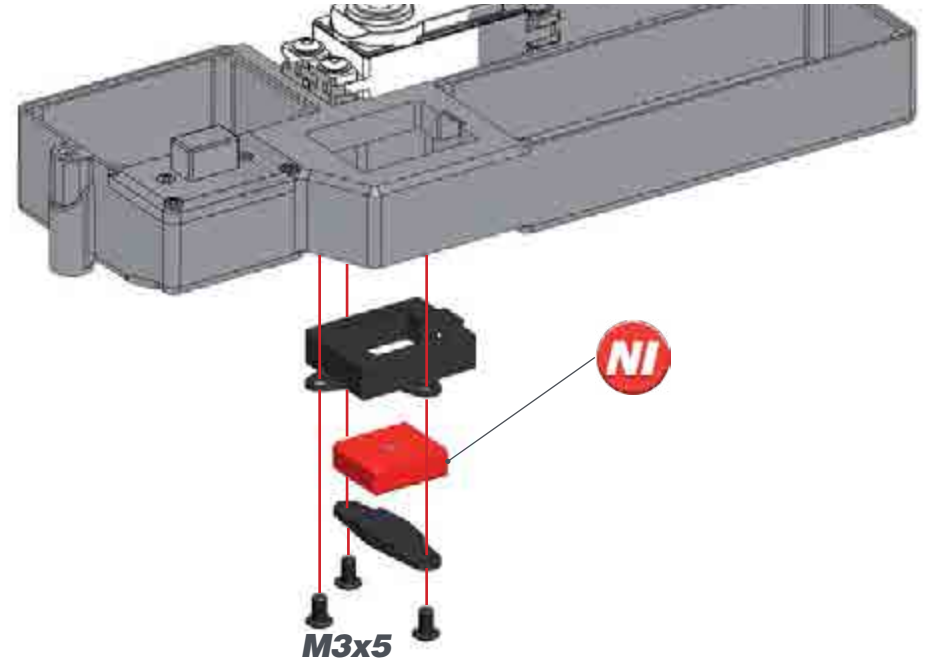

STEP 48

48.1

Apply the supplied decal on the battery cover.

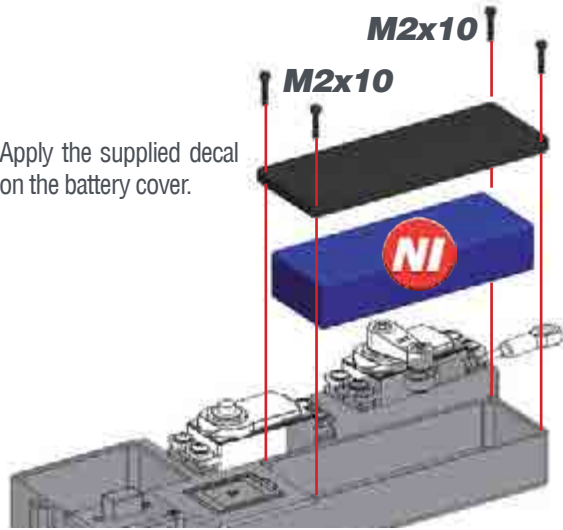

48.2

2

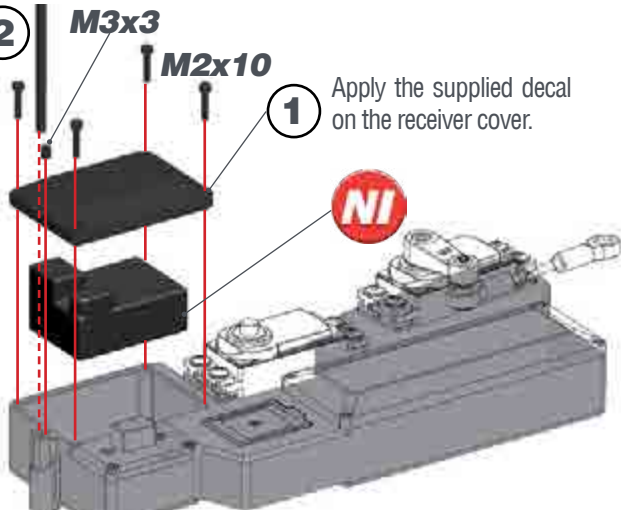

1

Apply the supplied decal on the receiver cover.

STEP 49

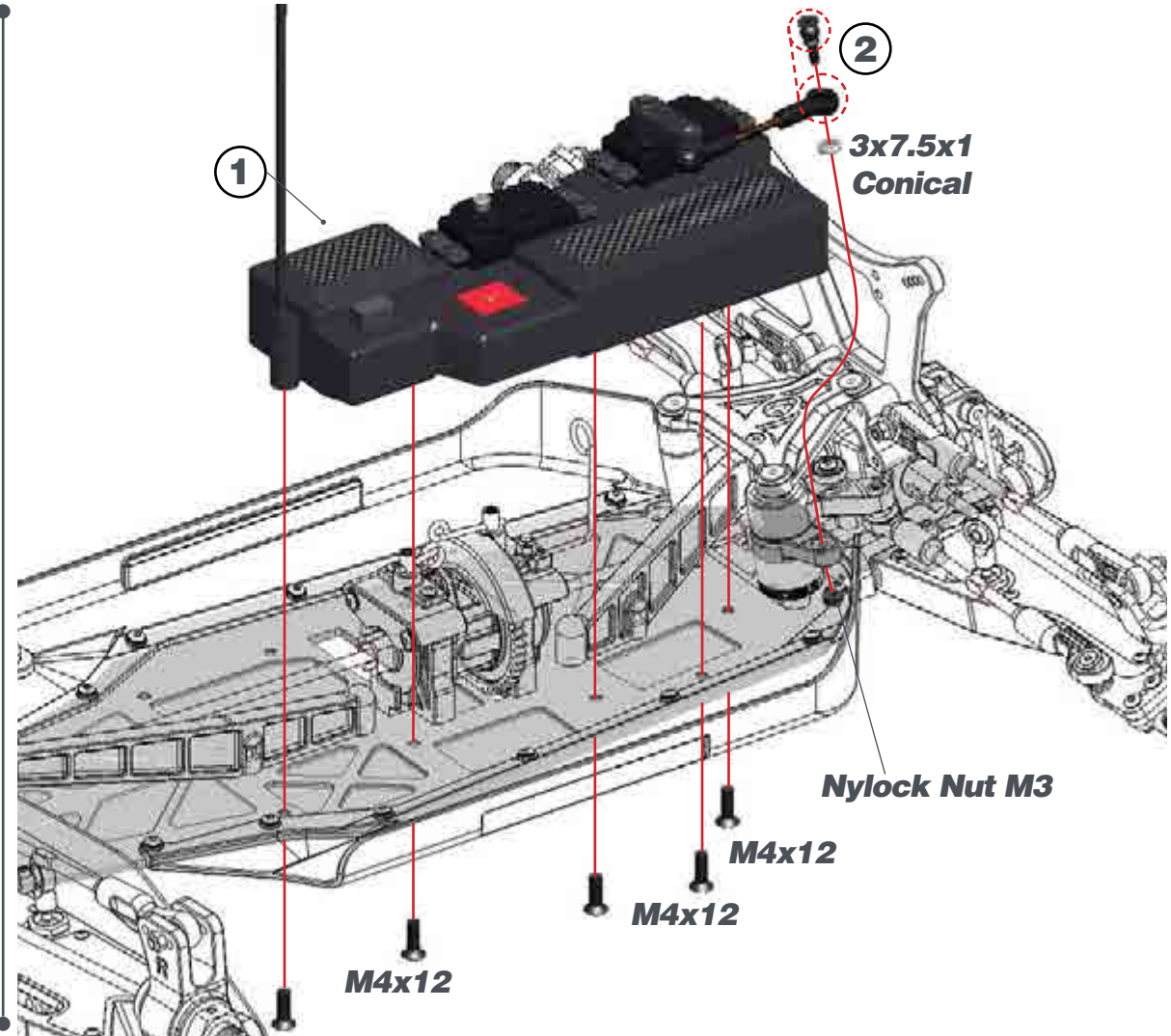

1

2

3x7.5x1 Conical

Nylock Nut M3

M4x12

M4x12

M4x12

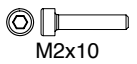

M2x10



M3x3

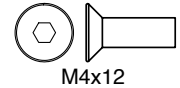

M4x12

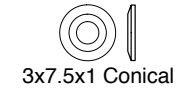

3x7.5x1 Conical



Nylock Nut M3

STEP 50

THROTTLE / BRAKE SPOKE LENGTHS

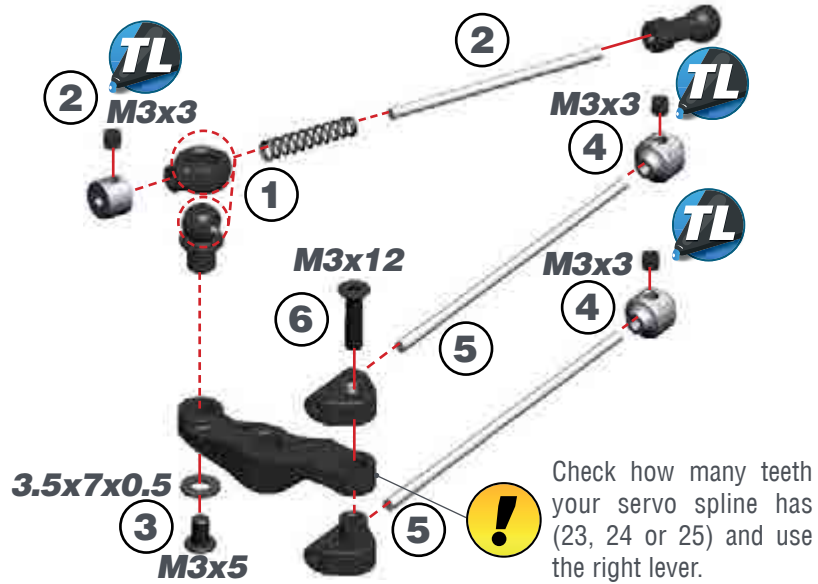
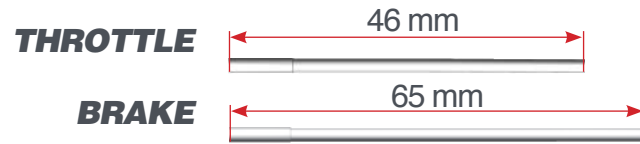

THROTTLE / BRAKE ASSEMBLY

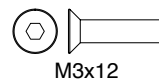
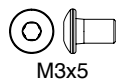
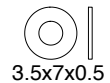

STEP 51

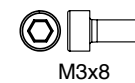
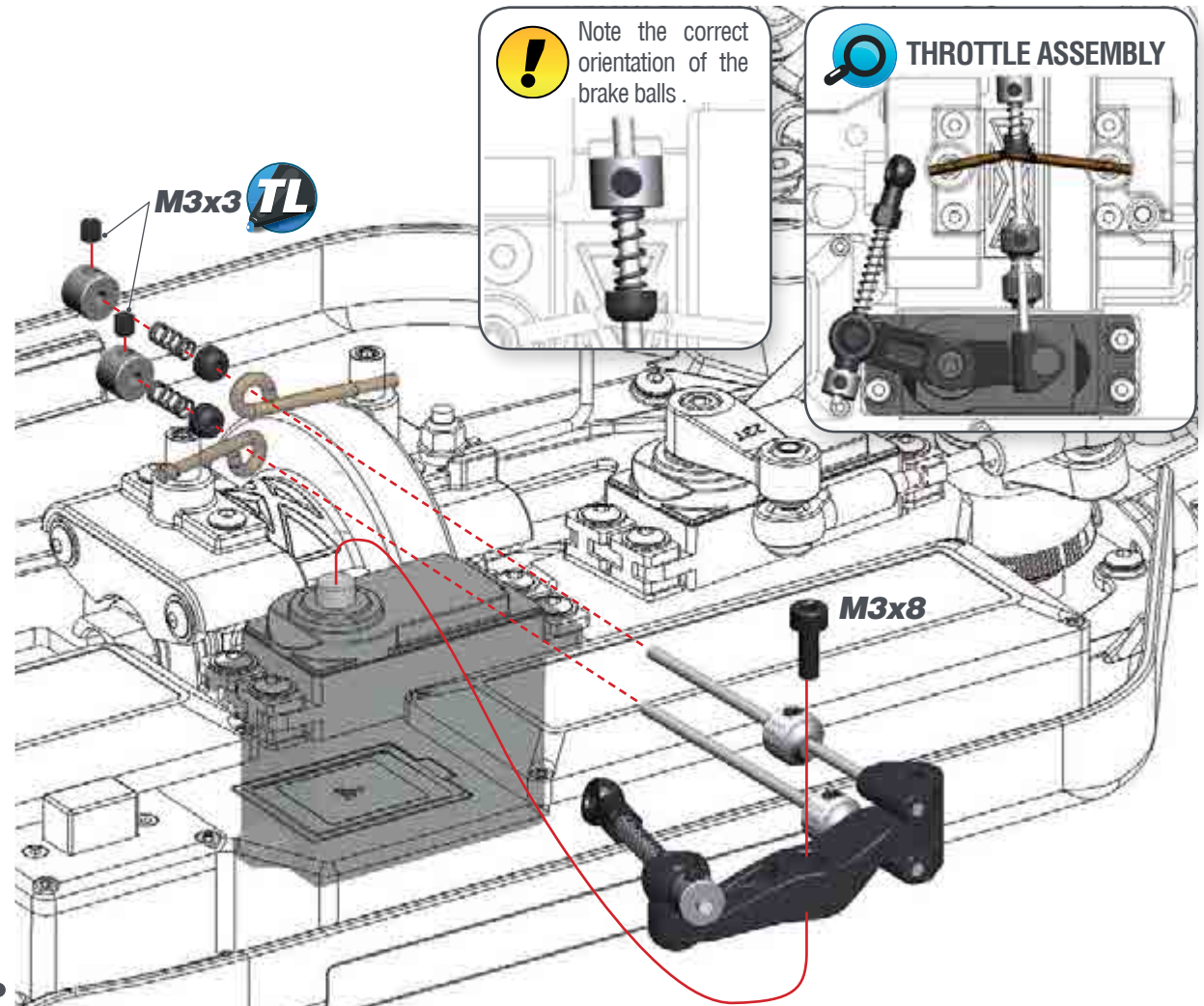

STEP 52 BAG 13 FR SHOCKS / BAG 14 RR SHOCKS / STEP 53

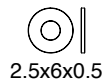
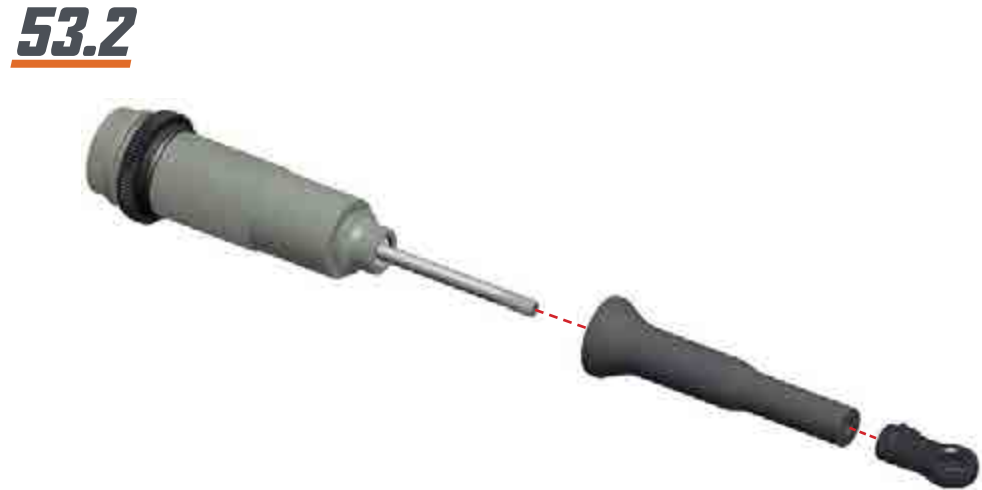
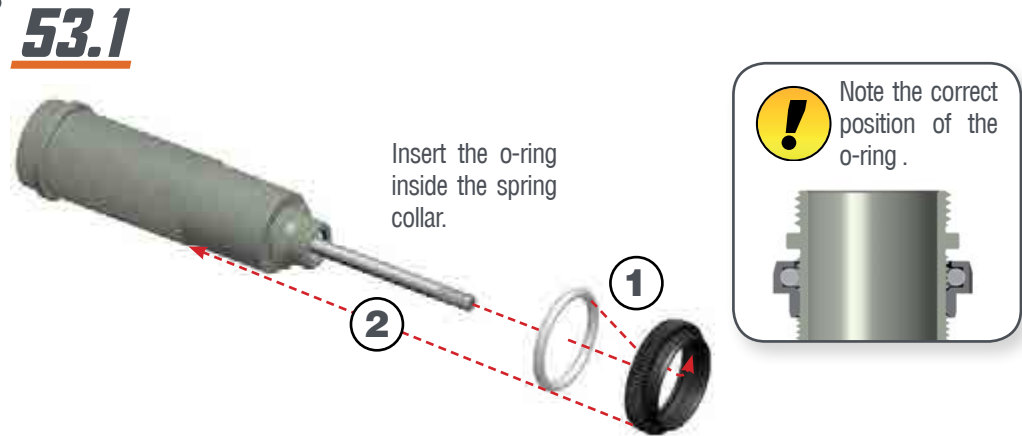
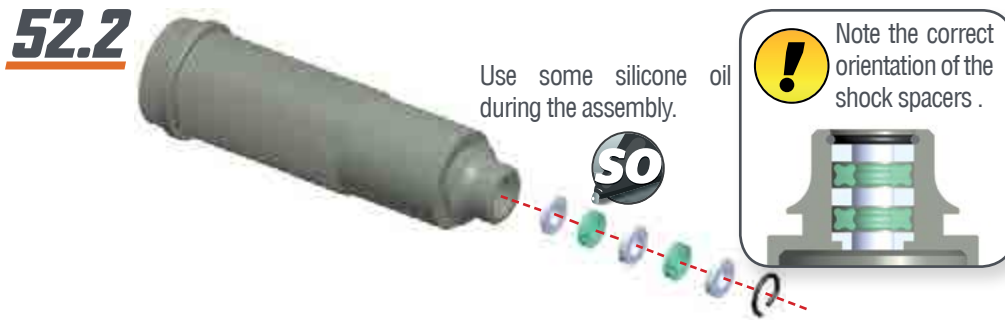
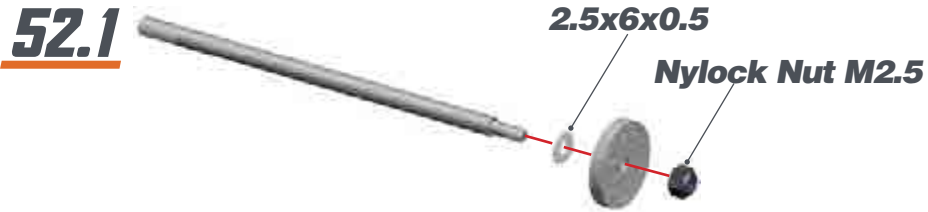

STEP 54

54.1

Push the membrane into the shock cap.



54.2

1- Fill up with silicone oil fully using the silicone oil supplied in the kit. For the correct cst value please check the default setupsheet.



2- Extend the shockrod fully

3- Move the shockrod slowly up and down to let ALL air bubbles escape.

4- Apply the gasket and cap and close fully.

54.3

1-Bleed: push the shock-rod all the way in slowly, to allow excessive oil to escape.

2- With shockrod fully in, mount the o-ring and screw.

M2.3x4



SHOCKS LENGTH: Measure the shock length fully extended.

FRONT

REAR

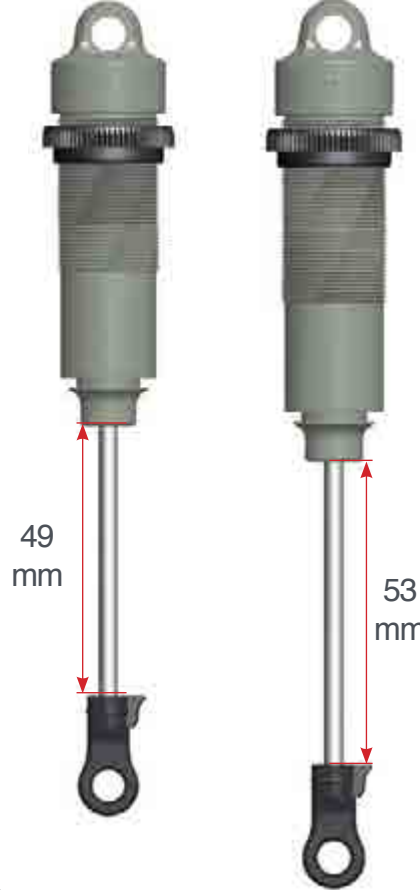

STEP 55

Assemble the spring and spring-cup (align correctly) to complete the shock.

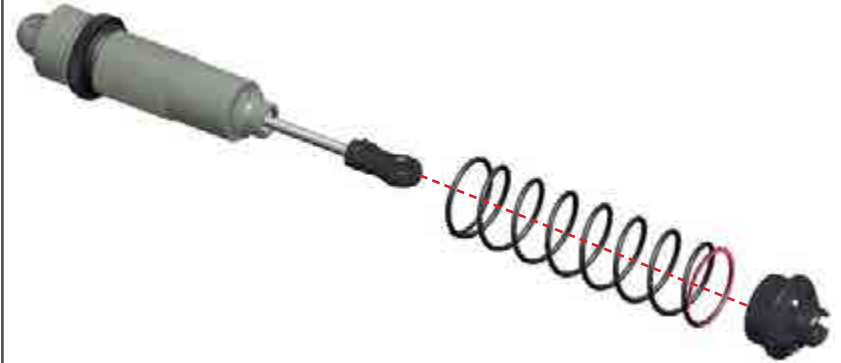

M2.3x4

STEP 56

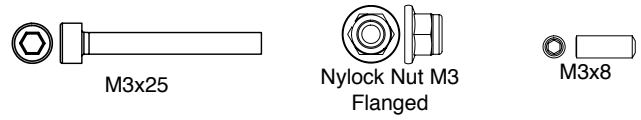
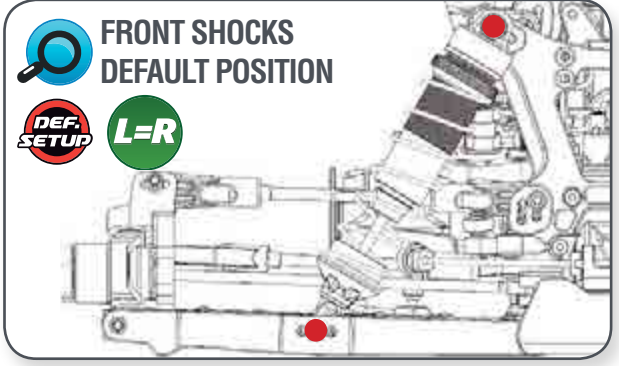
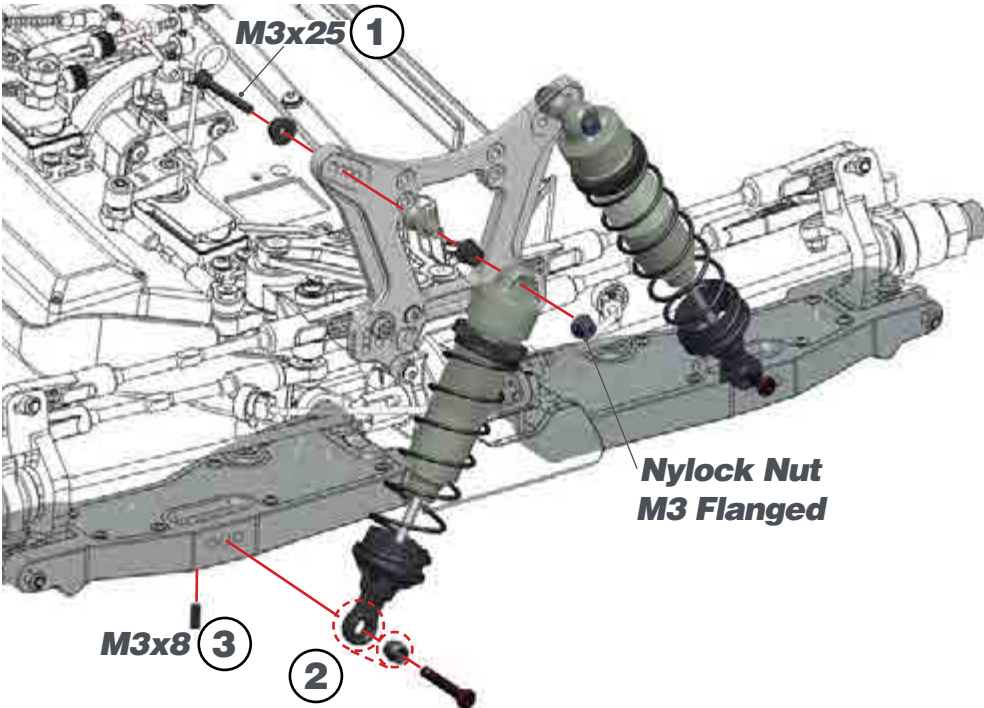

STEP 57

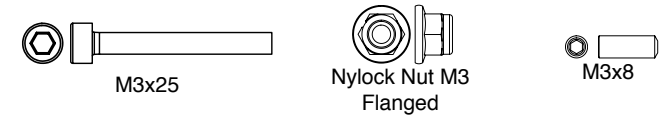
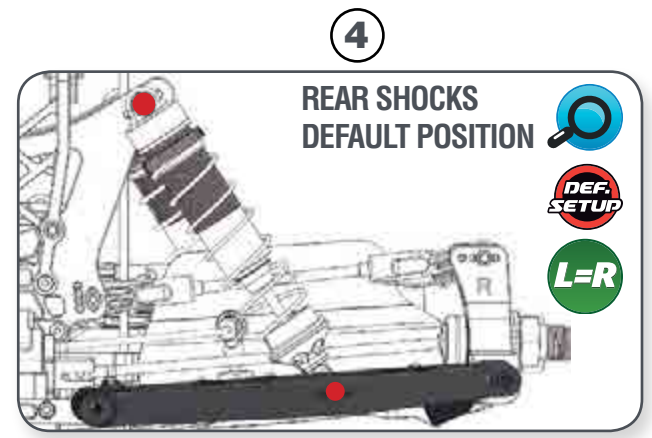
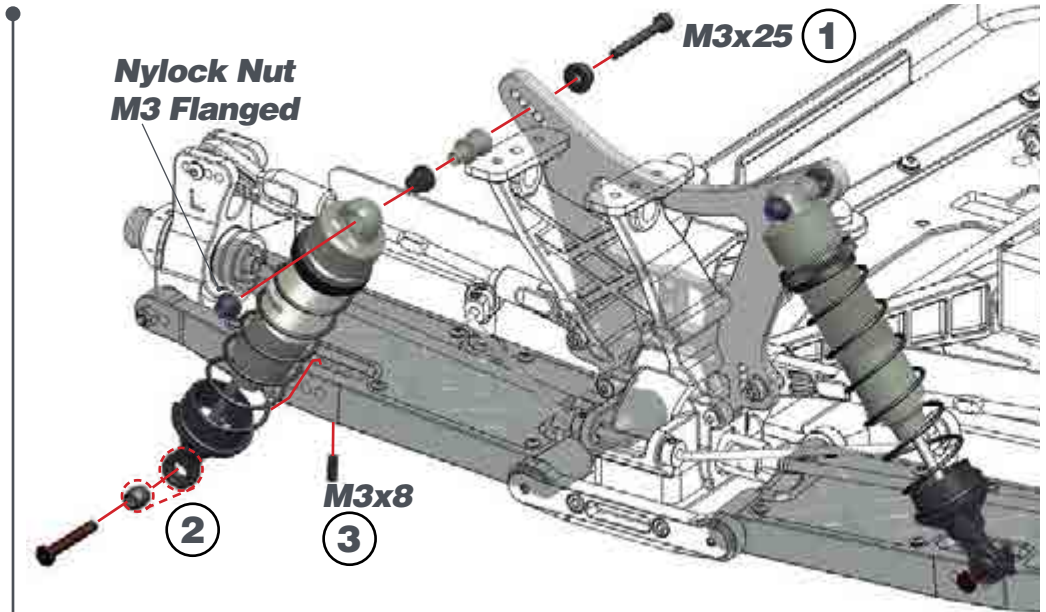

STEP 58 BAG 15

58.1



FUEL TANK INSERTS

The fuel-tank features a premounted 3cc insert. You can remove it if needed as shown.

M3x14

58.2

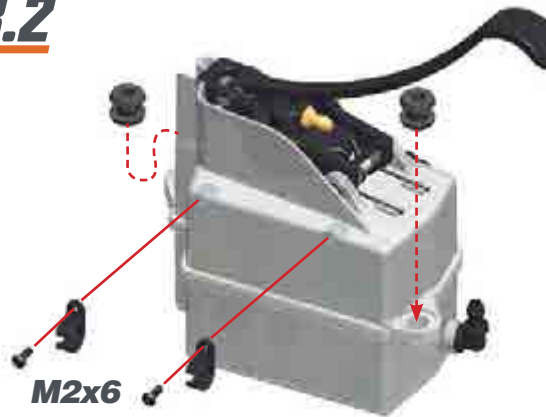

58.3

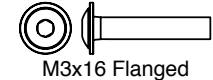
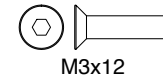
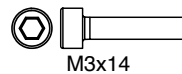
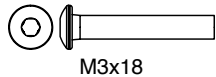
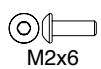
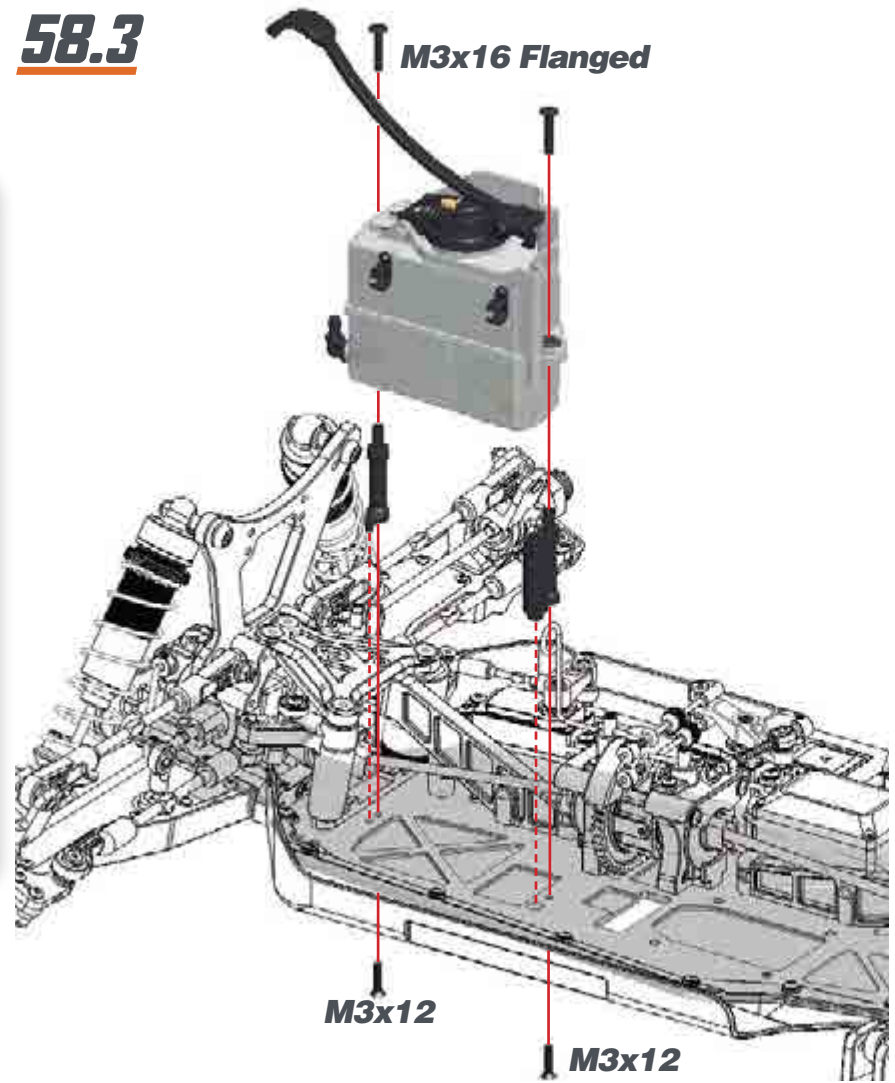

STEP 59 BAG 16

59.1  Push the long leg of the spring in the inner hole of the clutch shoe.

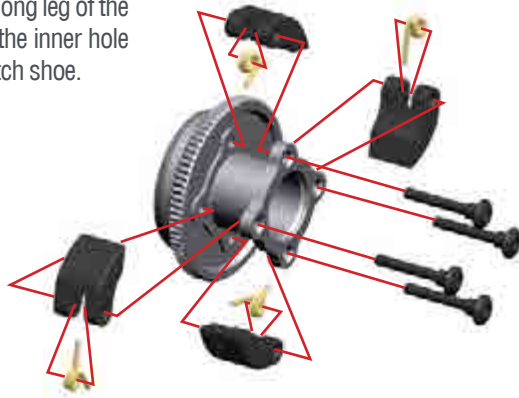

59.2

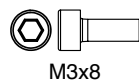
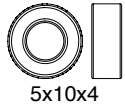
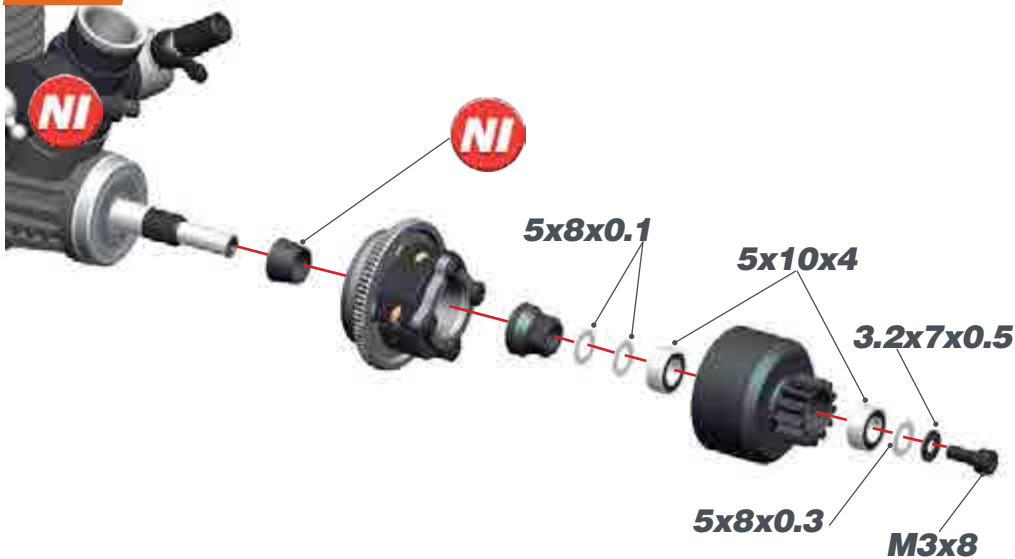

STEP 60

! Do not fully tighten the M3x14 screws till Step 61.

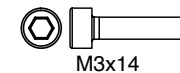
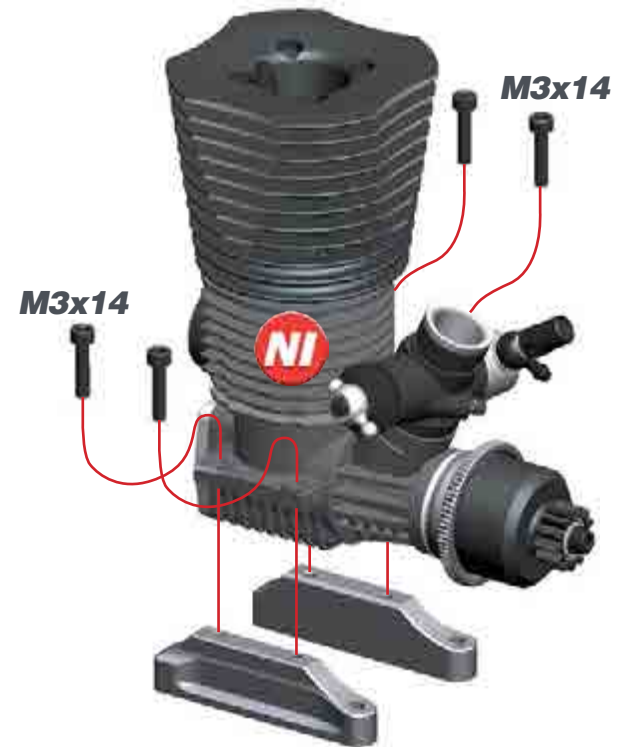

STEP 61



- 1- Assemble and fully tighten the M4x10 screws.
- 2- Position the engine in such way on the engine mount that the gearmesh is correct.
- 3- Fully tighten M3x14 screws assembled during the Step 60.



If the engine used is an OS (or OS based engines like Mx), Alpha and SH, it might be needed to trim off some plastic from the center diff cover to give the carburetor enough clearance over the brake plates. This could be done with a hobby knife.

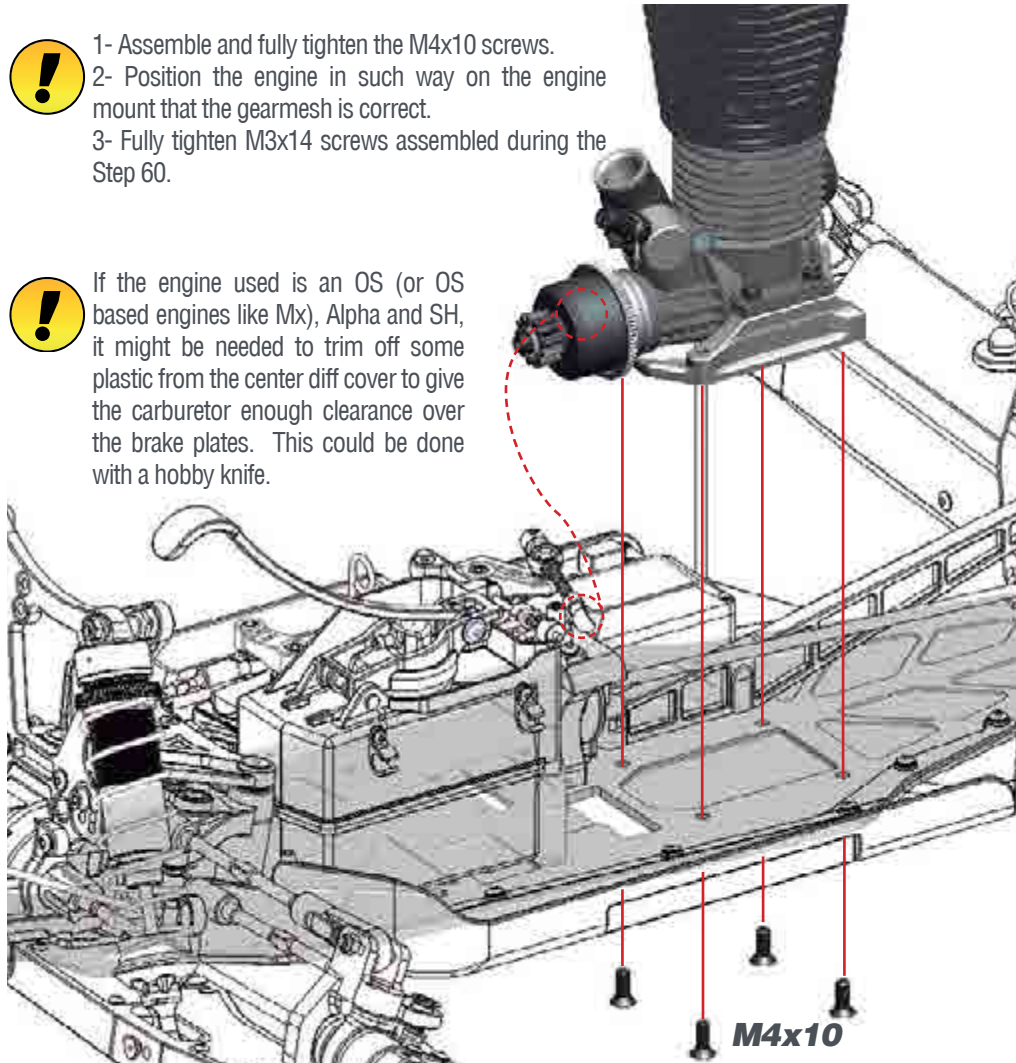

M4x10

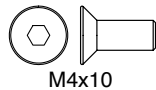

STEP 62

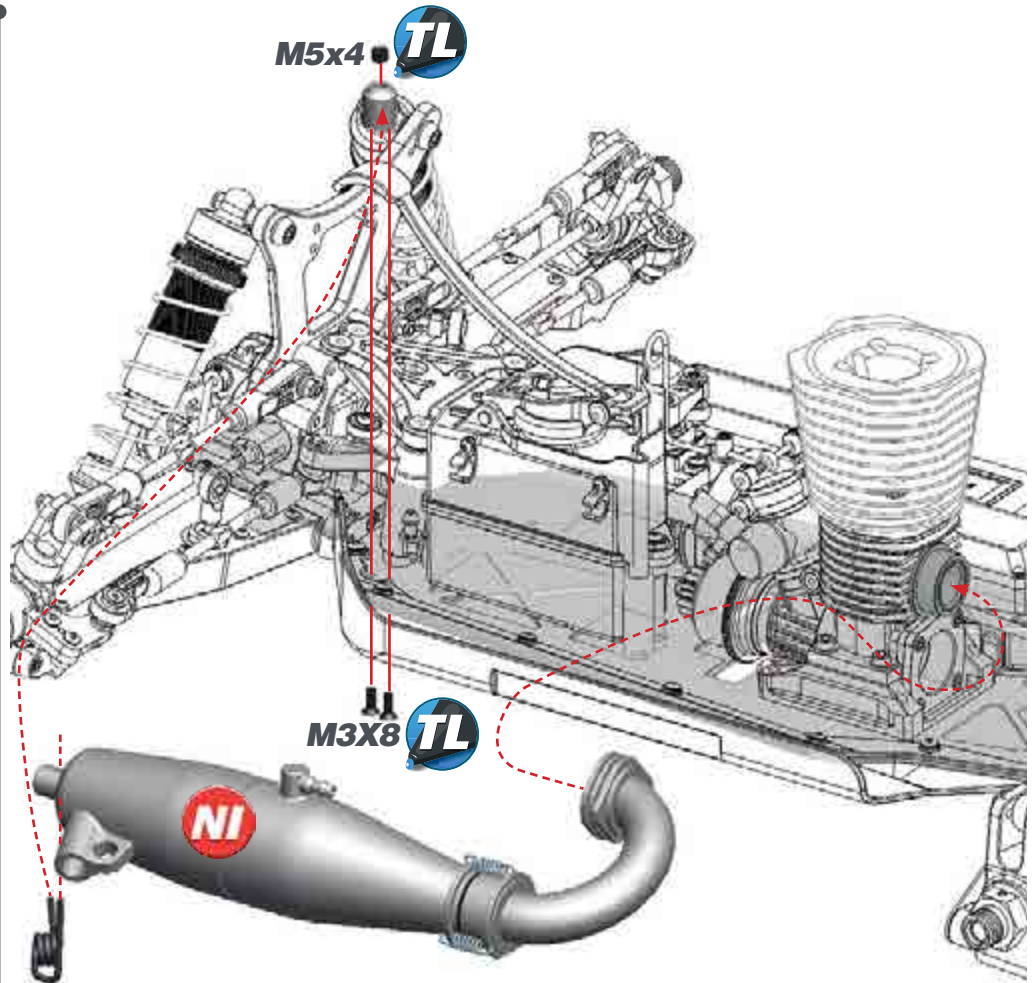

M5x4



M3x8



STEP 63 BAG 17

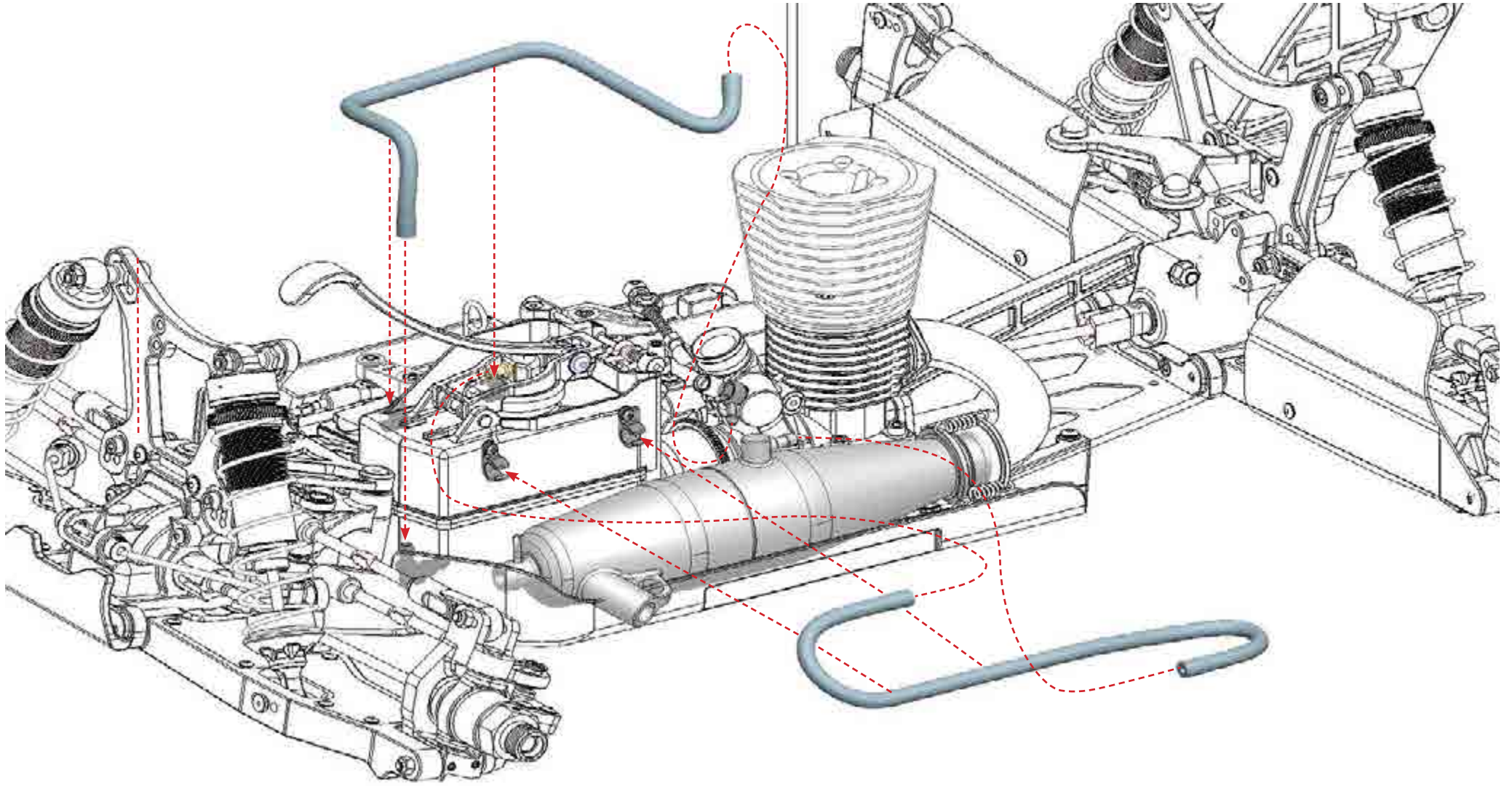

STEP 64

64.1

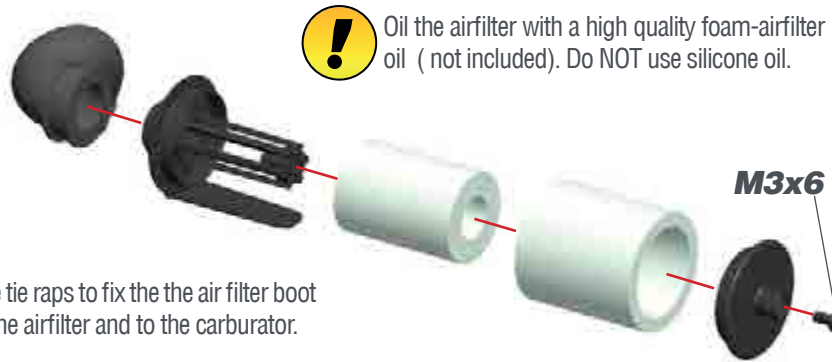

! Use tie raps to fix the the air filter boot to the airfilter and to the carburator.

64.2

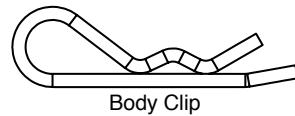
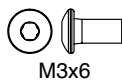
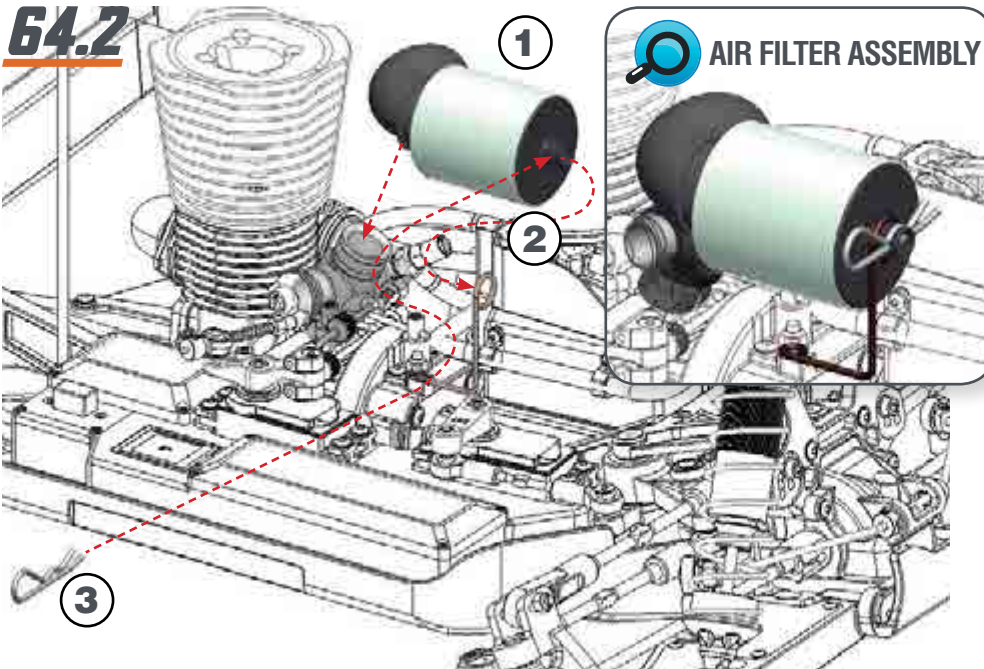

STEP 65

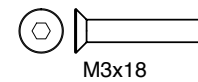
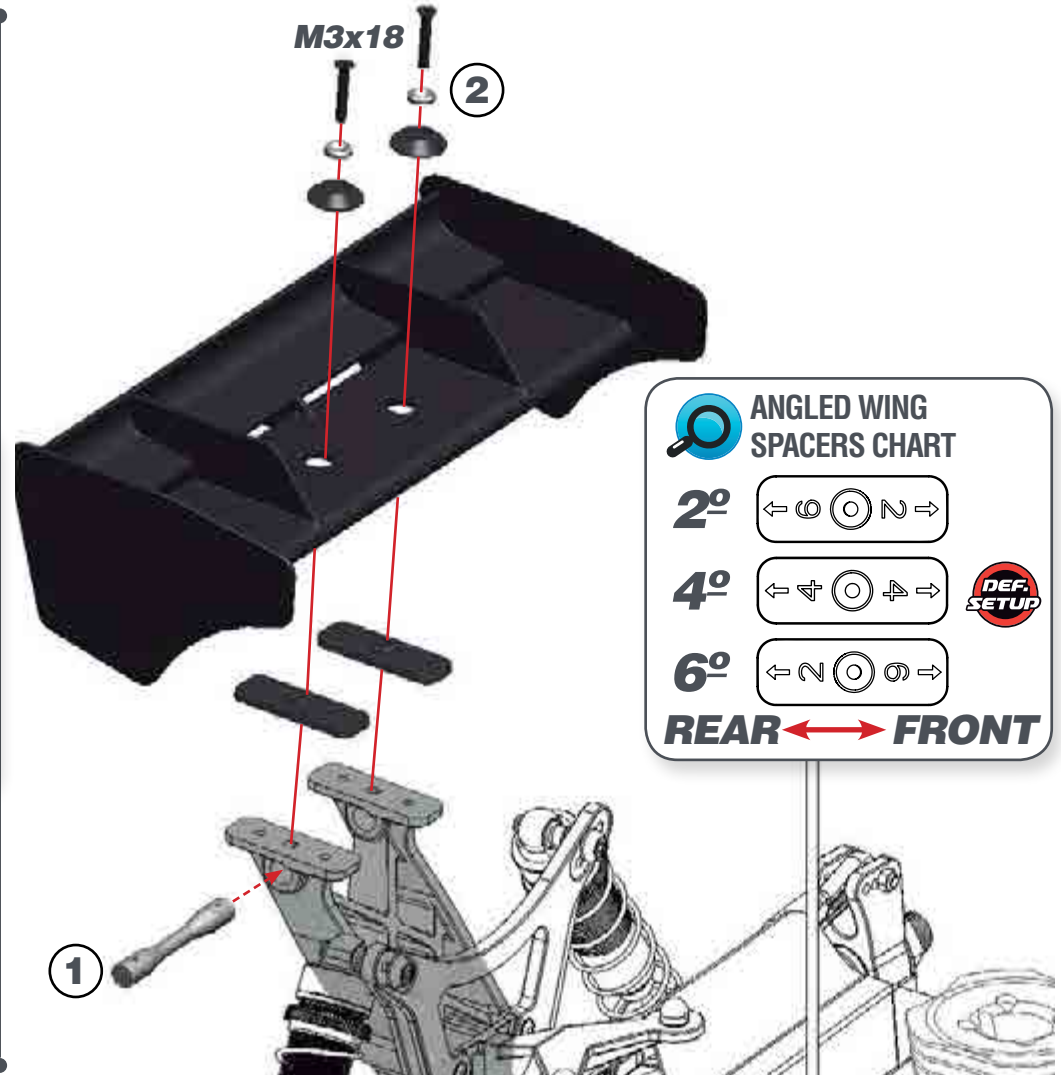

STEP 66

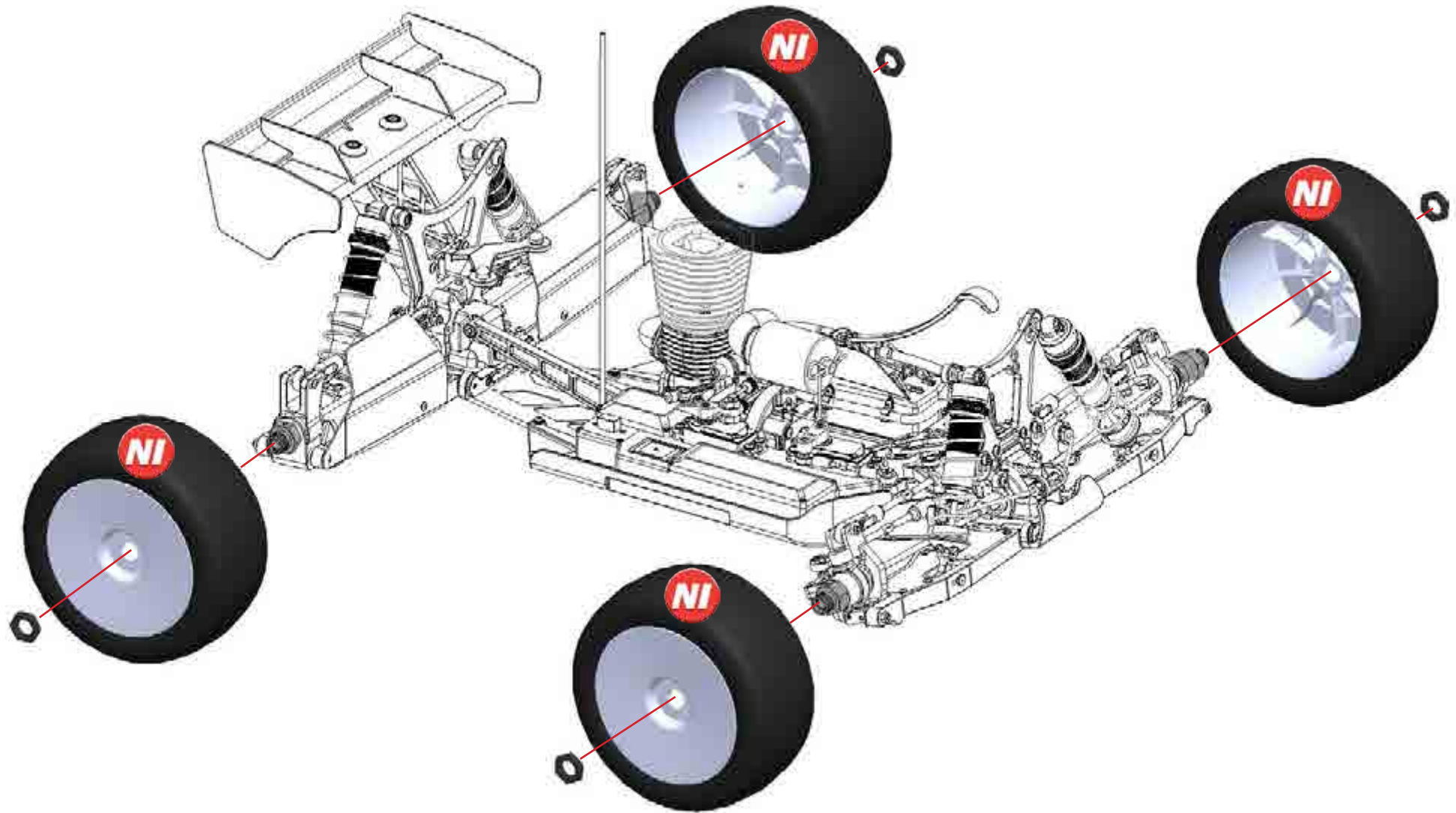

STEP 67

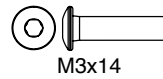
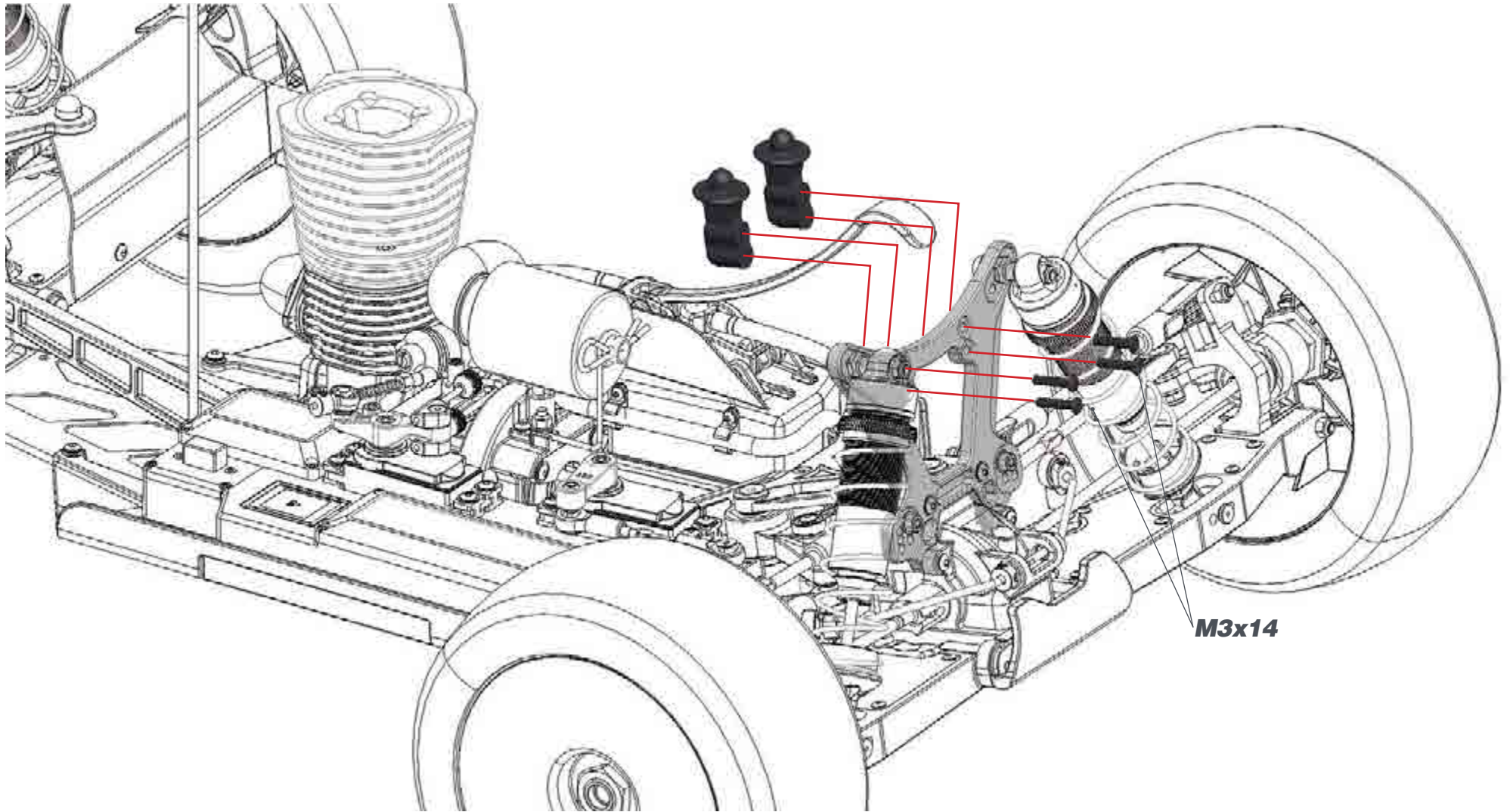

STEP 68

1- Cut the body along the cutting line with special scissors (not included). Make holes for the bodypost and antenna as needed with a body reamer (not included). Make a longer bodypost hole in the rear, to allow for chassis flex movement.

2- Before painting the body, apply the pre-cut masking sheet elements to the inside of the body. Follow the cleaning & painting instructions supplied by the polycarbonate paint supplier you choose.

3- Apply the Serpent and Cobra logo-decals on the body and wing.

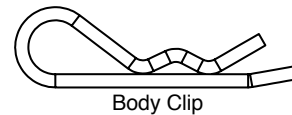
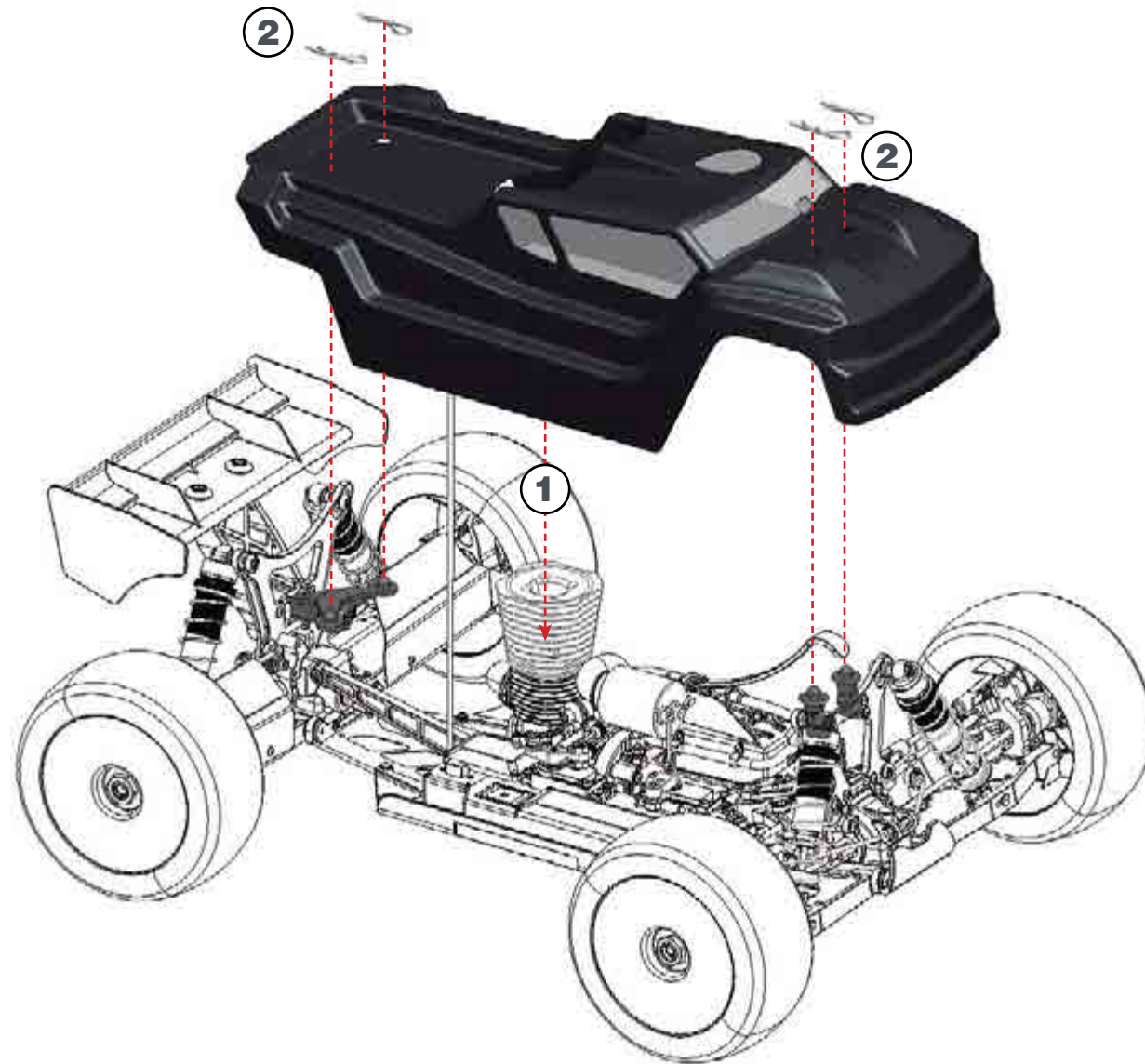

INDEX

<i>DIFFERENTIALS EXPLODED VIEW</i>	44
<i>CENTRAL EXPLODED VIEW</i>	45
<i>REAR EXPLODED VIEW</i>	46
<i>FRONT EXPLODED VIEW</i>	47
<i>STEERING EXPLODED VIEW</i>	48
<i>RADIO EXPLODED VIEW</i>	49
<i>SHOCKS EXPLODED VIEW</i>	50
<i>CLUTCH EXPLODED VIEW</i>	51
<i>FINAL 1 EXPLODED VIEW</i>	52
<i>FINAL 2 EXPLODED VIEW</i>	53

DIFFERENTIAL EXPLODED VIEW

601144 HTD diff set 46T fr/r SRX8
 601145 HTD diff set 48T center SRX8



601064 HTD spur gear 47T SRX8
 601072 HTD diff pin 10T alu (2) SRX8
 601063 HTD spur gear 46T SRX8



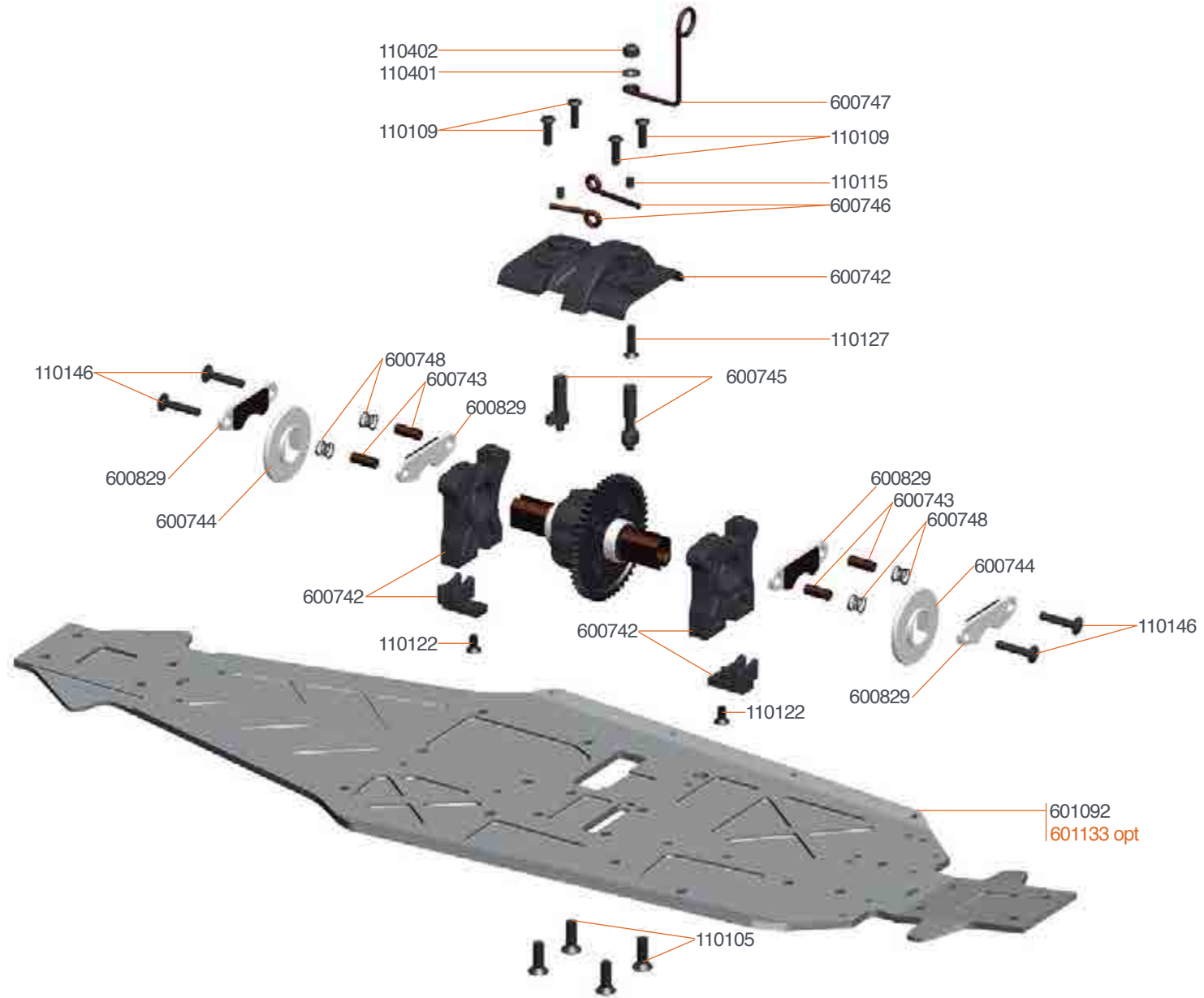

601133 Chassis alu hard coated SRX8T



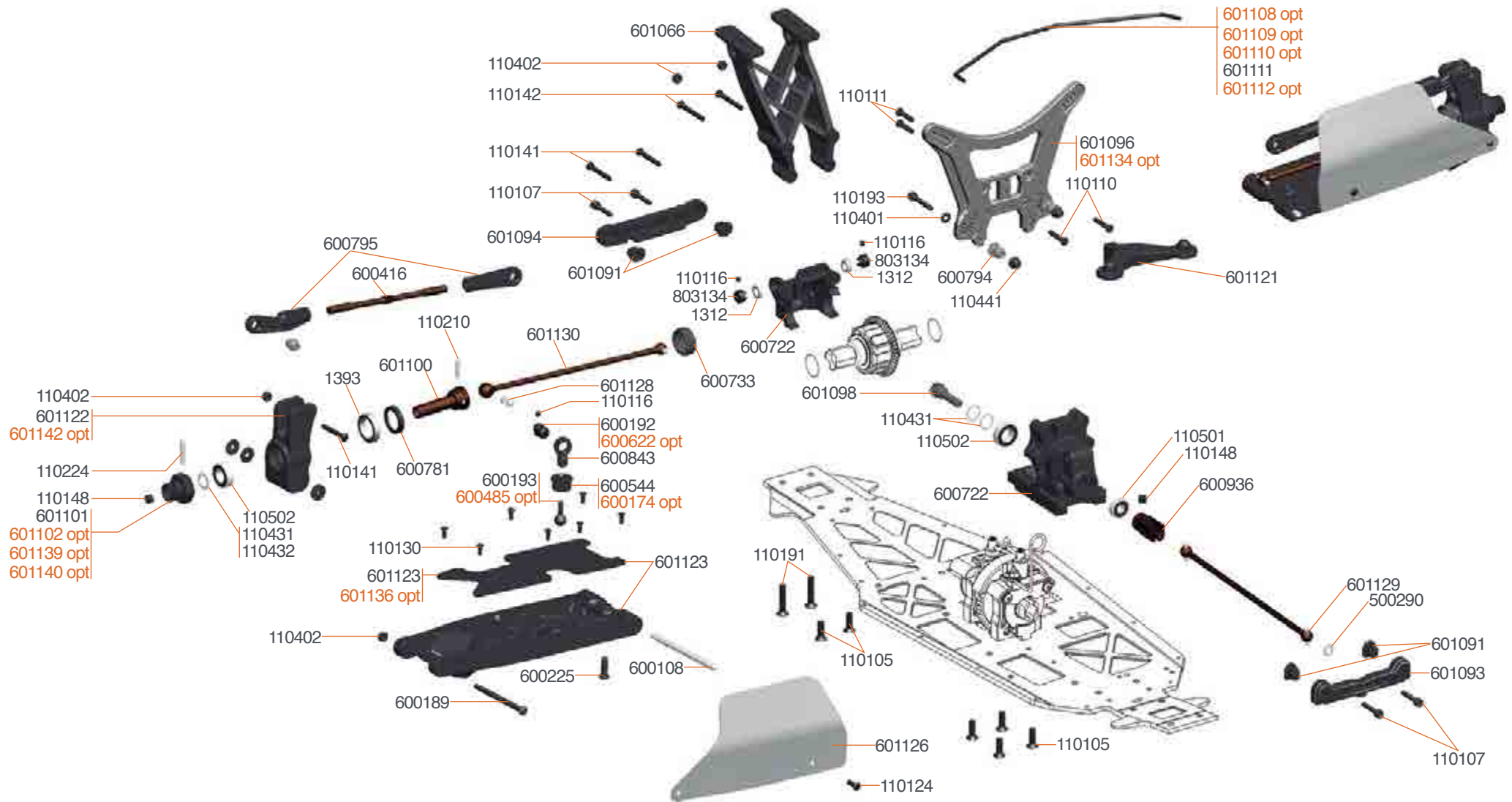

- 600174 Antirollbar nut (2)
- 600484 Antirollbar spacer 3mm alu (2)
- 600485 Pivotball threaded anti roll bar alu (2)
- 600622 Pivotball antirollbar alu (4)
- 600853 Gear coupler alu SRX8

- 601102 Wheelhexagon +1mm (2) SRX8T
- 601108 Antiroll bar rr 2.2mm SRX8T
- 601109 Antiroll bar rr 2.3mm SRX8T
- 601110 Antiroll bar rr 2.4mm SRX8T
- 601112 Antiroll bar rr 2.6mm SRX8T

- 601134 Shocktower rr carbon SRX8T
- 601139 Wheelhexagon 0mm light (2) SRX8T
- 601140 Wheelhexagon +1mm light (2) SRX8T
- 601142 Upright L+R alu SRX8T



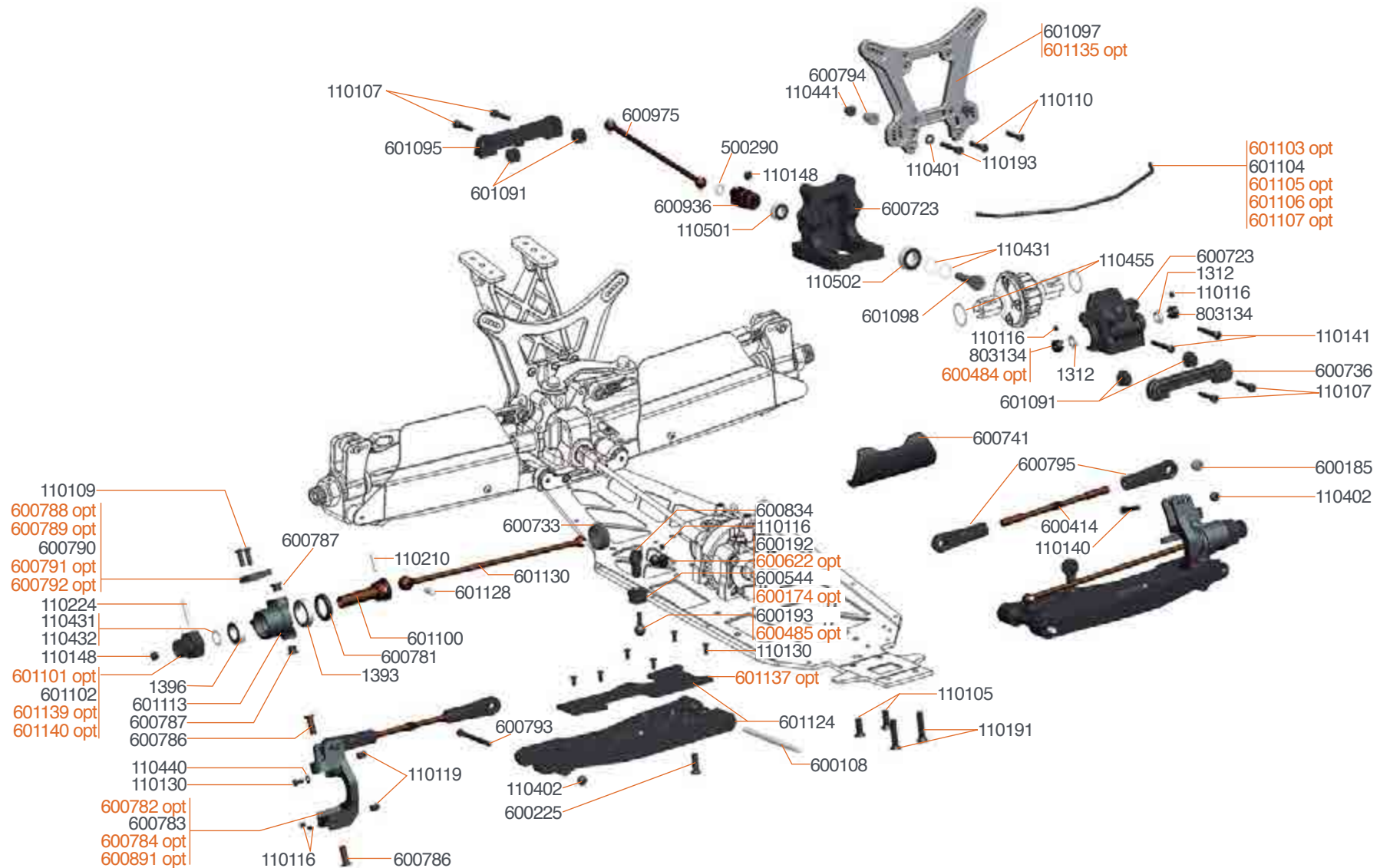

- 600174 Antirollbar nut (2)
- 600484 Antirollbar spacer 3mm alu (2)
- 600485 Pivotball threaded anti roll bar alu (2)
- 600622 Pivotball antirollbar alu (4)
- 600782 C-hub 13deg L+R alu SRX8
- 600784 C-hub 17deg L+R alu SRX8
- 600788 Steering arm 0 carbon (2) SRX8

- 600789 Steering arm 1 carbon (2) SRX8
- 600791 Steering arm 3 carbon (2) SRX8
- 600792 Steering arm 4 carbon (2) SRX8
- 600891 C-hub 19deg L+R alu SRX8
- 601101 Wheelhexagon 0mm (2) SRX8T
- 601103 Antiroll bar fr 2.2mm SRX8T
- 601105 Antiroll bar fr 2.4mm SRX8T

- 601106 Antiroll bar fr 2.5mm SRX8T
- 601107 Antiroll bar fr 2.6mm SRX8T
- 601135 Shocktower fr carbon SRX8T
- 601139 Wheelhexagon 0mm light (2) SRX8T
- 601140 Wheelhexagon +1mm light (2) SRX8T



STEERING EXPLODED VIEW

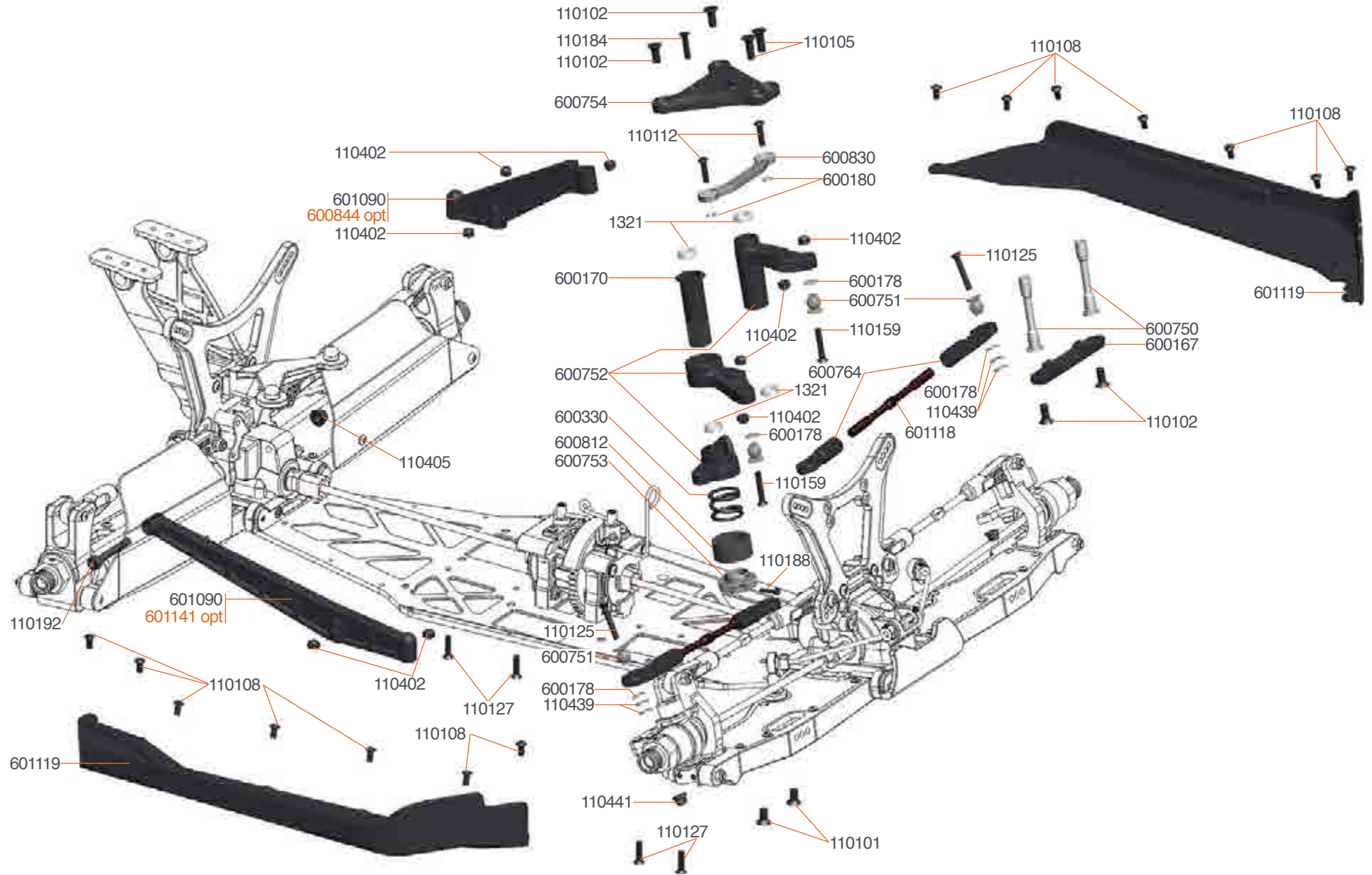

600844 Transmission brace alu FR SRX8
601141 Transmission brace alu RR SRX8T

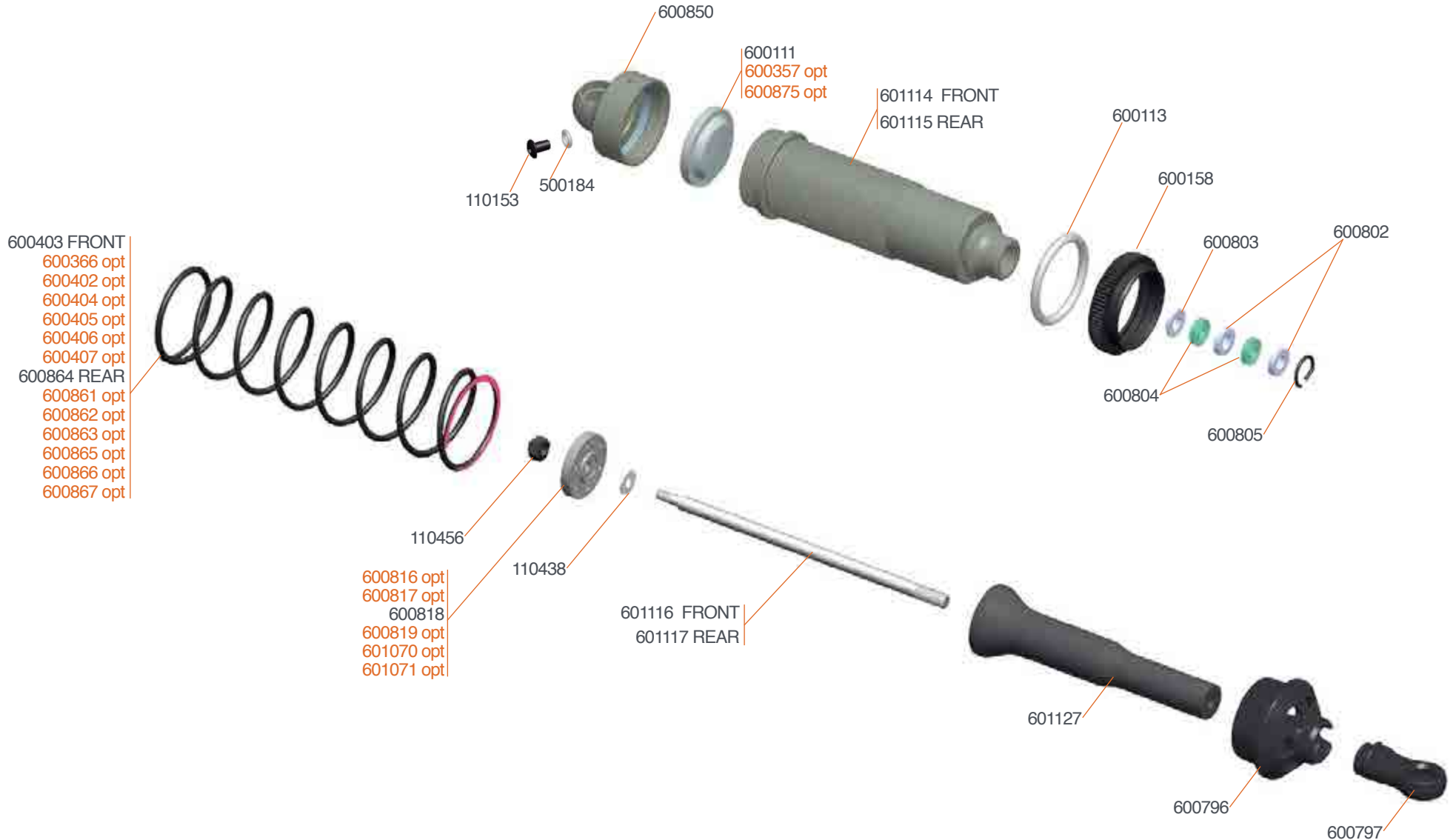

- 600357 Membrane webbed silicone (4)
- 600861 Shockspring RR 3.0 lbs orange (2)
- 600862 Shockspring RR 3.2 lbs red (2)
- 600865 Shockspring RR 3.8 lbs purple (2)
- 600866 Shockspring RR 4.0 lbs green (2)
- 600867 Shockspring set RR (6x2)

- 600366 Spring set FR Truggy (7x2)
- 600402 Spring set FR Pink 4,8lbs (2)
- 600404 Spring set FR Purple 5.2 lbs (2)
- 600405 Spring set FR Green 5,4 lbs (2)
- 600406 Spring set FR Gray 5,6 lbs (2)
- 600407 Spring set FR Yellow 5.8 lbs (2)

- 600357 Membrane webbed silicone (4)
- 600816 Shock piston blank (4) SRX8
- 600817 Shock piston 5 holes (4) SRX8
- 600819 Shock piston 8 holes (4) SRX8
- 600875 Shock top gasket (4) SRX8
- 600863 Shockspring RR pink 3.4lbs (2)

- 601070 Shock piston angled 1.2mm 8holes (4) SRX8
- 601071 Shock piston angled 1.3mm 8holes (4) SRX8



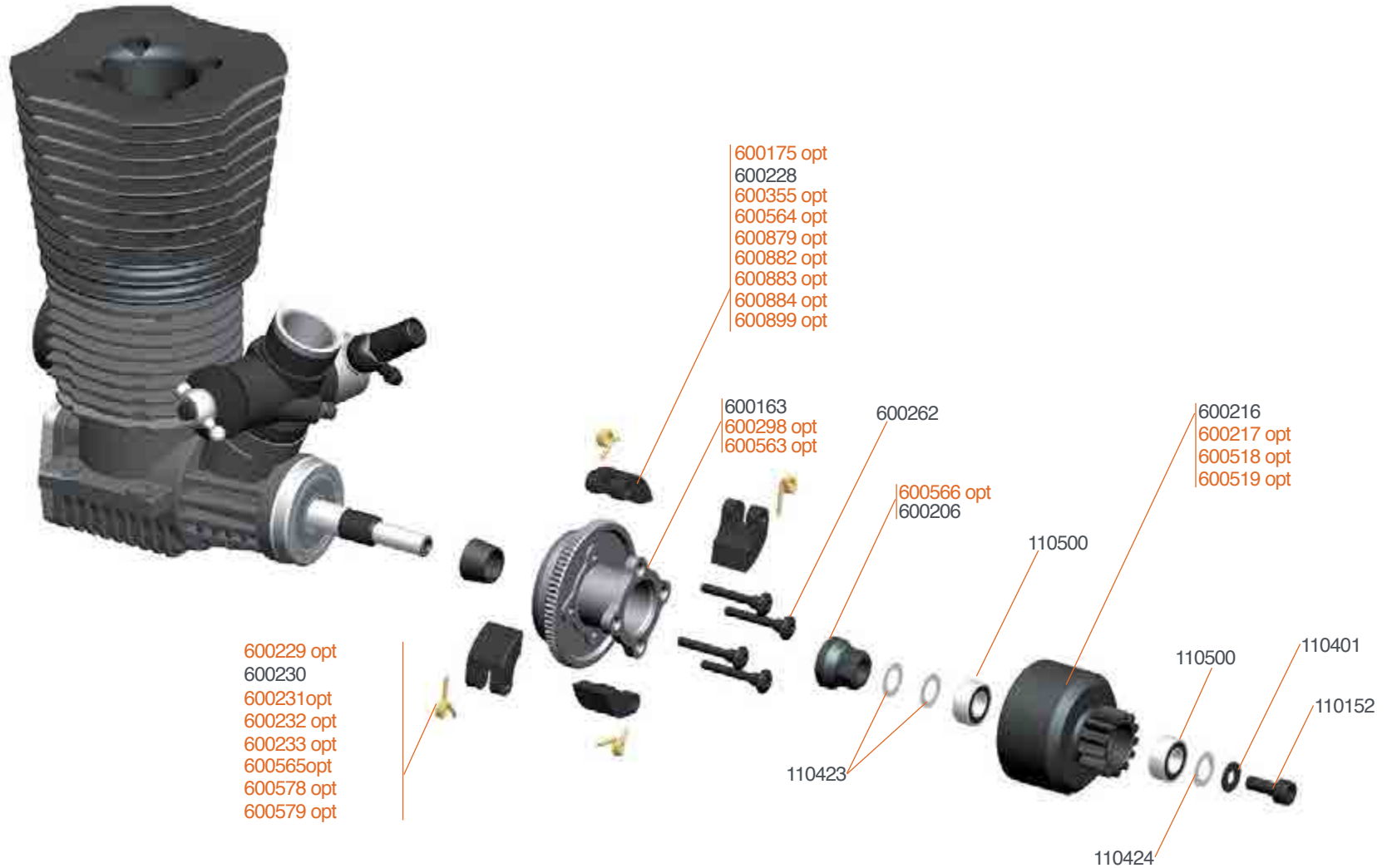

600518 Clutch bell 13T vented
600519 Clutch bell 14T vented
600217 Clutch bell 14T
600229 Clutch spring soft 0.85mm (4)
600231 Clutch spring hard 0.95mm(4)
600232 Clutch spring X hard 1mm(4)
600233 Clutch spring set (4x4)

600175 Clutchshoe alu (4)
600355 Clutch shoe set Alu / Carbon (2+2)
600244 Clutch-set alu / carbon
600298 Flywheel steel
600563 Flywheel 3-pin alu
600565 Clutch spring 3-pin 0.9mm (3)
600578 Clutch spring 3-pin 1.0mm (3)

600579 Clutch spring 3-pin 1.0mm (3)
600564 Clutch shoe 3-pin carbon (3)
600566 Clutch nut 3-pin
600879 Clutch shoe yellow (4)
600882 Clutch shoe 4-pin alu 6061 (4)
600883 Clutch shoe 3-pin alu 6061 (3)
600884 Clutch shoe 3-pin alu 7075 (3)



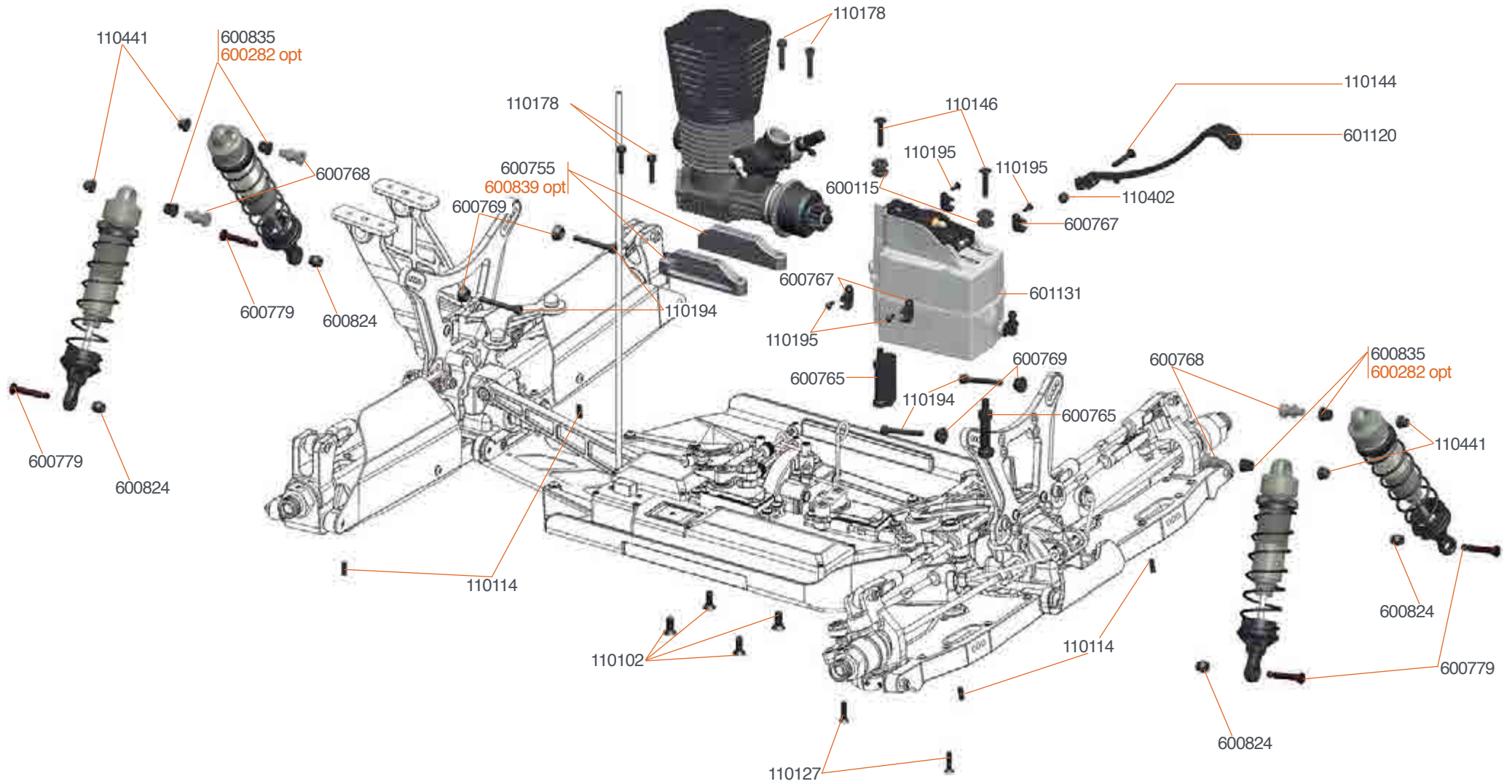

OPT 600282 Shock-pivot bushing delrin (4)
 600839 Motormount mono alu SRX8

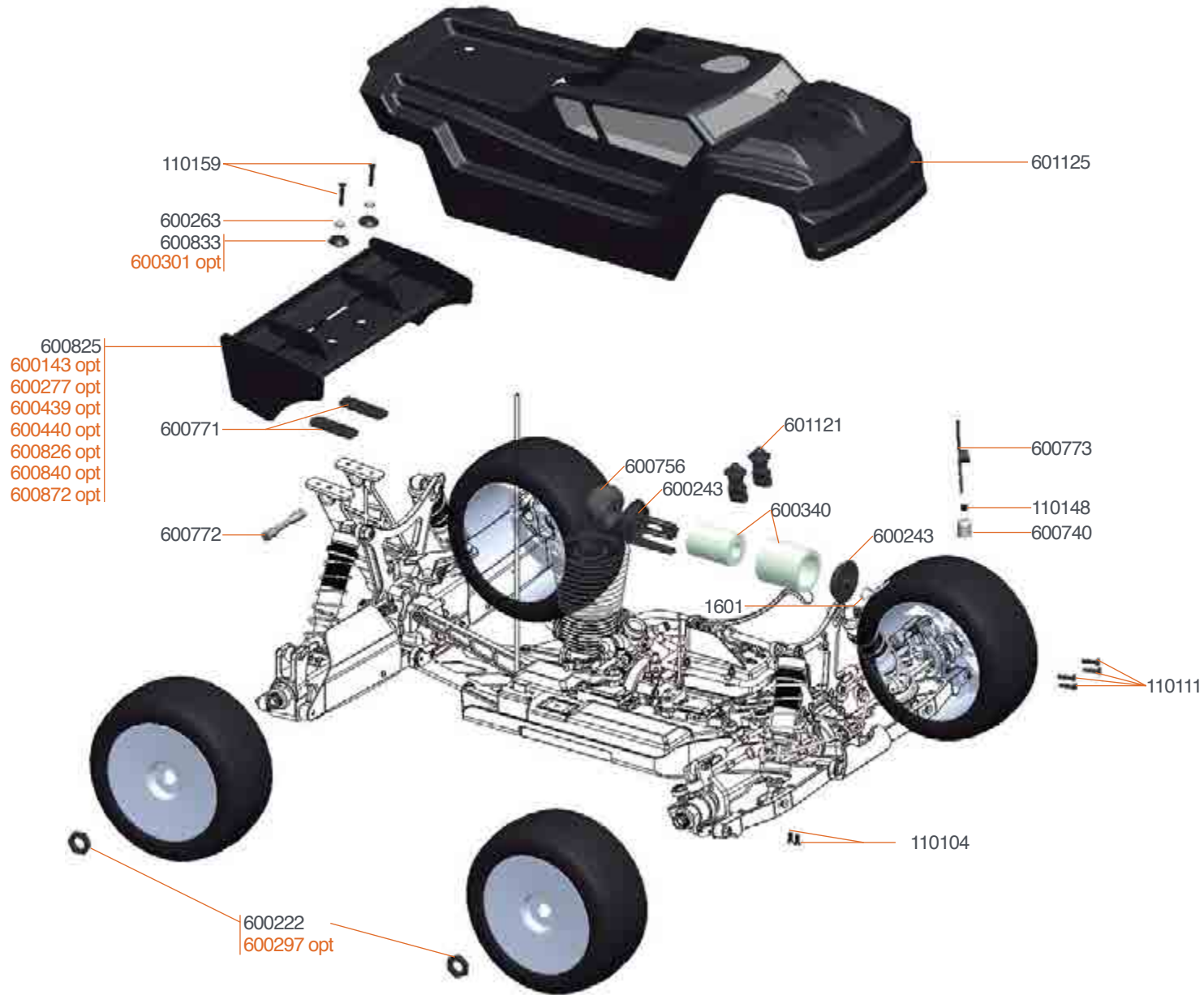

600297 Wheel-nut 17mm flanged/light (4)
 600143 Wing white nylon
 600277 Wing black nylon

600439 Wing white low 811
 600440 Wing black low 811
 600719 Body SRX8 High Downforce

600826 Wing straight MD white 1/8
 600840 Wing lexan HD with gurney 1/8
 600872 Wing gurney

600620 Rim 1/8 buggy White (4)
 600621 Rim 1/8 buggy Yellow (4)

TEAM SERPENT NETWORK

SRX8 TRUGGY SPARE PARTS www.serpent.com/600059/spares/



SRX8 TRUGGY OPTIONALS PARTS www.serpent.com/600059/Optionals/



SERPENT TOOLS www.serpent.com/product/Tools/

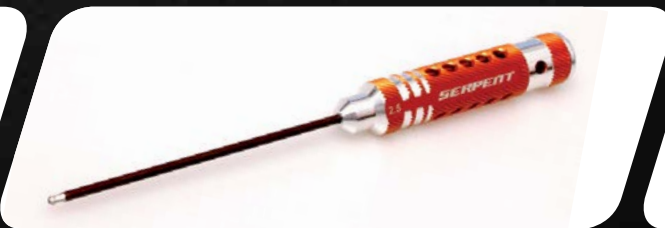

SERPENT MERCHANDISING www.serpent.com/product/Merchandising/



SERPENT WEBSITE AND BLOG

www.serpent.com
www.teamserpent.com
www.dragon-rc.com

SERPENT PROMO PAGES <http://promo.serpent.com>

SERPENT FACEBOOK GROUPS <http://promo.serpent.com/indexfb.htm>

SERPENT ADVANCED MANUALS <http://promo.serpent.com/sam/>

SERPENT SOCIAL MEDIA



www.facebook.com/SerpentMRC



www.youtube.com/user/SerpentMRC



www.twitter.com/SerpentMRC



www.plus.google.com/+SerpentModelcars/posts



www.weibo.com/teamserpent

TRUGGY SRX8

SCALE 1/8 GAS



Manual SRX8T #83222

SERPENT
INNOVATIONS