

- En Instruction Manual
- De Bauanleitung
- Fr Manuel de montage

[www.HBRACING.com](http://www.HBRACING.com)

# D418

COMPETITION 1/10 SCALE 4WD ELECTRIC BUGGY



HB D418 KIT En De Fr Vol.1 204379

## Thank you

Thank you for selecting this HB Racing product! This kit is designed to be fun to drive and uses top quality parts for durability and performance. The instruction manual you are reading was designed to be easy to follow yet thorough in its explanations. HB Racing wants you to enjoy driving your new HB Racing product. If you come across any problems or need some help getting through a step, give us a call and we will do our very best to help you. You can also contact us on the internet at [www.hbracing.com](http://www.hbracing.com)

- This is a high performance R/C kit, and it requires regular maintenance for best performance. If you don't do regular maintenance the performance will suffer. HB Racing has all the necessary parts and accessories available to keep your car performing at its best.

The caution or attention symbols will warn you about steps that can be very dangerous. Please read and understand the instructions carefully before proceeding.



### Caution

Failure to follow these instructions can damage your kit, and cause serious bodily injury or death.



### Attention

Failure to follow these instructions can cause injury to yourself or others. You might also cause property damage or damage to your kit.



### Caution

#### Before Running

- Please read manual with parent or guardian (responsible adult).

#### Before Operating

- Make sure that all screws and nuts are properly tightened.
- Always use fresh batteries for transmitter and receiver to avoid losing control of the model.
- Make sure no one else is using the same radio frequency as you are using.
- Please confirm the range of the radio operation.

#### During Running

- Please do not run on a public street, this could cause serious accidents, personal injuries and/or property damage.
- Please do not run near pedestrians or small children.
- Please do not run in small or confined areas.

#### After Running

- Turn OFF receiver first, then turn OFF transmitter. This will prevent the car from losing control.

#### Battery Safety

- Please be careful when handling the battery. It will be hot after running. If the wire is frayed, a short circuit can cause a fire.



# 4 TIME WORLD CHAMPIONS

[www.HBRACING.COM](http://www.HBRACING.COM)

## Danke

Vielen Dank, dass Sie sich für HB Racing entschieden haben! Dieses Auto soll Spaß machen und verwendet nur hochwertige Materialien für beste Leistungen und Haltbarkeit. Die Anleitung, die Sie gerade lesen, ist einfach zu verstehen und dabei sehr ausführlich. HB Racing will, dass Sie Erfolg und Spaß mit Ihrem neuen Modell haben! Falls es dennoch einmal zu Problemen kommen sollte, melden Sie sich bei uns. Wir werden alles in unserer Macht stehende tun, um zu helfen. Sie können uns auch gerne unter [www.hbracing.com](http://www.hbracing.com) kontaktieren.

- Dies ist ein hochleistungs RC-Auto und benötigt regelmäßige Wartung. Wenn Sie diese Wartungsarbeiten nicht durchführen wird die Leistung des Autos darunter leiden. Alle zur Wartung benötigten Teile sind bei HB Racing erhältlich.

Die Warnsymbole weisen Sie auf gefährliche Bauabschnitte hin.  
Bitte lesen und verstehen Sie die Anweisungen bevor Sie sie durchführen.



### Warnhinweise

Wenn Sie diesen Anweisungen nicht folgen, können Sie oder Ihr Auto Schäden davontragen.



### Achtung

Wenn Sie diesen Anweisungen nicht folgen, können Sie oder andere verletzt werden. Es kann auch sein, dass dabei Sachschaden an anderen Dingen oder ihrem Auto entsteht.



### Warnhinweise

#### Vor dem Fahren

- Bitte lesen Sie die Anleitung (zusammen mit einem Erwachsenen/Erziehungsberechtigten).

#### Vor dem Betrieb

- Stellen Sie sicher, dass alle Schrauben und Muttern korrekt sitzen.
- Verwenden Sie immer volle Batterien für den Sender und Empfänger, um Empfangsstörungen zu vermeiden.
- Stellen Sie sicher, dass niemand anderes die gleiche Frequenz verwendet.
- Überprüfen Sie die Reichweite der RC-Anlage.

#### Während dem Fahren

- Fahren Sie nicht auf öffentlichen Straßen. Dies kann zu schweren Unfällen mit Personen- oder Sachschäden führen.
- Fahren Sie nicht in der Nähe von Fußgängern oder kleinen Kindern.
- Fahren Sie nicht auf zu kleinen oder zu eng begrenzten Geländen.

#### Nach dem Fahren

- Schalten Sie den Empfänger aus, dann erst den Sender. Dies verhindert, dass das Auto außer Kontrolle gerät.

#### Hinweise zum Fahrakku

- Geben Sie im Umgang mit dem Fahrakku bitte Acht. Er ist nach dem Fahren sehr heiß. Falls die Kabel beschädigt sind, kann ein Kurzschluss ein Feuer auslösen.

## Merci

Merci d'avoir choisi ce produit HB Racing! Ce kit a été conçu pour être amusant à conduire, et utilise des pièces de la plus haute qualité pour la longévité et les performances. Le manuel d'utilisation qui est entre vos mains a été conçu pour vous fournir des explications faciles à suivre mais complètes. HB Racing espère que vous aurez plaisir à piloter votre nouveau kit radio-commandé. Si vous rencontrez des problèmes ou si vous avez besoin d'aide pour une étape, appelez-nous et nous ferons de notre mieux pour vous aider. Vous pouvez aussi nous contacter par Internet sur [www.hbracing.com](http://www.hbracing.com).

- Ceci est un kit radio-commandé de hautes performances, et requiert un entretien régulier pour donner le meilleur de lui-même. Si vous n'effectuez pas un entretien régulier, les performances en souffriront. HB Racing a toutes les pièces et les accessoires nécessaires pour maintenir les performances de votre véhicule à leur meilleur niveau.

Les symboles attirant votre attention vous avertiront des étapes qui peuvent être très dangereuses. Veuillez lire soigneusement les instructions et bien les comprendre avant toute utilisation.



### Précautions

En ne suivant pas ces instructions vous pourriez endommager votre kit, et provoquer de sérieux dégâts corporels ou même mortels.



### Attention

En ne suivant pas ces instructions vous pourriez vous blesser vous-même ou blesser d'autres personnes. Vous pourriez également provoquer des dégâts matériels ou endommager votre kit.



### Précautions

#### Avant de mettre en marche

- Veuillez lire le manuel avec un parent ou un adulte responsable.

#### Avant de mettre en marche

- Vérifiez que toutes les vis et les boulons sont correctement serrés.
- Utilisez toujours des batteries nouvellement chargées pour l'émetteur et le récepteur afin d'éviter de perdre le contrôle du véhicule.
- Vérifiez que personne d'autre n'utilise la même fréquence radio que vous.
- Vérifiez le champ d'action du fonctionnement de la radio.

#### Pendant le fonctionnement

- Ne faites pas fonctionner sur une voie publique, cela pourrait provoquer des accidents graves, des blessures corporelles et/ou des dommages aux biens.
- Ne faites pas fonctionner à proximité de piétons ou d'enfants en bas âge.
- Ne faites pas fonctionner dans des lieux petits ou fermés.

#### Après l'arrêt

- Éteignez d'abord le récepteur, puis l'émetteur. Cela empêchera une éventuelle perte de contrôle du véhicule.

#### Sécurité de la batterie

- Faites très attention lorsque vous manipulez la batterie. Elle sera très chaude après utilisation. Si un câble était dénudé, un court-circuit pourrait provoquer un incendie.

**Equipment Needed**  
**Benötigtes Zubehör**  
**Équipement nécessaire**

**Transmitter**  
**Sender**  
**Émetteur**

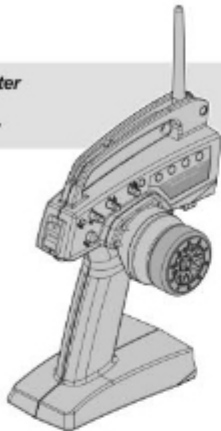

**Steering Servo**  
**Lenkservo**  
**Servo de direction**

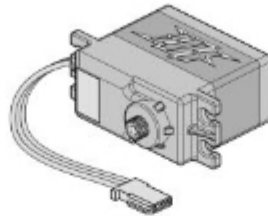

**Receiver**  
**Empfänger**  
**Récepteur**

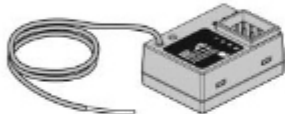

**Electronic Speed Control (ESC)**  
**Elektronischer Fahrtenregler (ESC)**  
**Contrôleur de vitesse (ESC)**

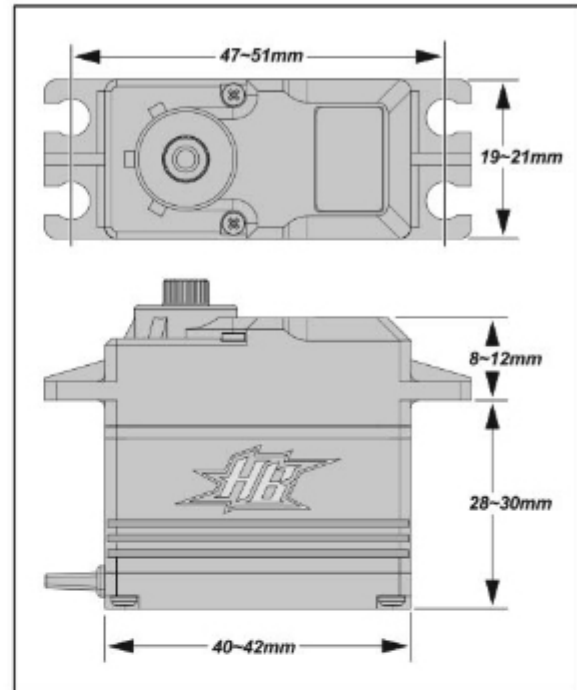
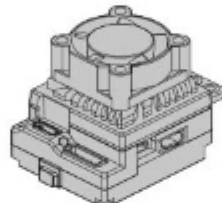

**Batteries for transmitter**  
**Senderbatterien**  
**Piles de l'émetteur**

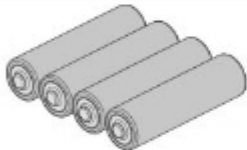

**Charger**  
**Ladegerät**  
**Chargeur**



**Electric Motor**  
**Elektromotor**  
**Moteur électrique**



**Pinion Gear (48 Pitch)**  
**Ritzel (48dp)**  
**Pignon (48 dp)**



**Tires**  
**Reifen**  
**Pneus**



**Shorty Battery**  
**Shorty-Pack**  
**Monobloc Batterie**

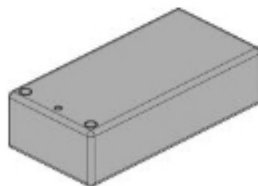

**Caution**  
**Warnhinweise**  
**Précautions**

*If you do not use a charger designed to charge Nickel Metal Hydride / LiPo batteries, the batteries will be damaged.*  
*Wenn Sie keinen geeigneten Lader zum Laden der Nickel-Metall-Hydrid oder LiPo Akkus verwenden, werden die Akkus beschädigt.*  
*Si vous n'utilisez pas un chargeur conçu pour recharger les batteries Nickel Métal Hydride ou LiPo, celles-ci seront endommagées.*

## Tools Werkzeuge Outils

Tools needed for assembly. Sold separately.

Zum Zusammenbau benötigtes Werkzeug. Separat erhältlich.

Outils nécessaires pour la mise en place, vendus séparément.

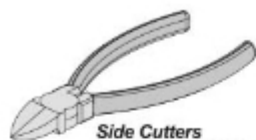

Side Cutters  
Seitenschneider  
Pincés coupantes

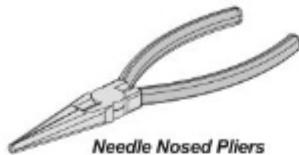

Needle Nosed Pliers  
Flachzange  
Pince à bec fin

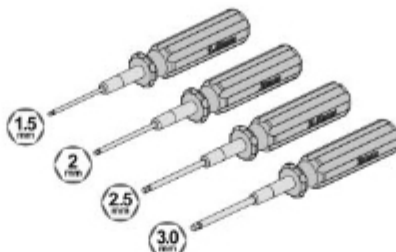

Allen Wrench 1.5mm / 2.0mm / 2.5mm / 3.0mm  
Inbusschlüssel 1.5mm / 2.0mm / 2.5mm / 3.0mm  
Clé Allen 1.5mm / 2.0mm / 2.5mm / 3.0mm

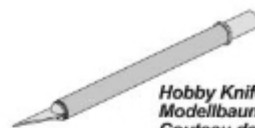

Hobby Knife  
Modellbaumesser  
Couteau de modélisme

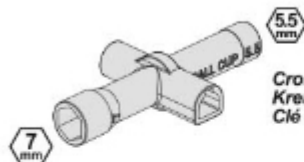

Cross Wrench  
Kreuzschlüssel  
Clé en croix

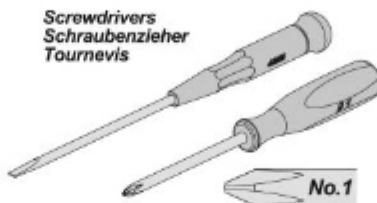

Screwdrivers  
Schraubenzieher  
Tournevis



Reamer  
Karosserieloch-Bohrer  
Alésoir

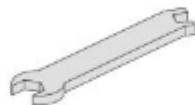

Turnbuckle Wrench  
Spurstangenschlüssel  
Clé à biellettes

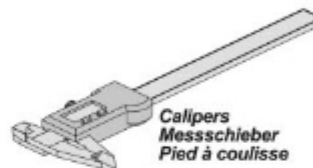

Callipers  
Messschieber  
Pied à coulisse

Thread Lock (Red)  
Schraubensicherung (Rot)  
Frein A Filet (Rouge)



Grease  
Fett  
Graisse



Instant Cement  
Sekundenkleber  
Colle rapide



Paint  
Lexanfarbe  
Peinture



## Included Items Enthaltenes Werkzeug Éléments inclus

ORI44422  
Silicone Oil #10,000  
Silikon Daempferoel #10,000  
Huile silicone 10,000



ORI44427  
Silicone Oil #100,000  
Silikon Daempferoel #100,000  
Huile silicone 100,000



## Caution Achtung Attention



Do not run in water or sand.  
Fahren Sie nie in Wasser oder Sand.  
Ne faites pas fonctionner dans l'eau ou sur le sable.

Do not run on public streets or highways. This could cause serious accidents, personal injuries, and/or property damage.  
Fahren Sie niemals auf öffentlichen Straßen. Dies kann zu schweren Unfällen mit Personen- und Sachschaden führen.  
Ne faites pas fonctionner sur la voie publique ou la route. Cela pourrait provoquer des accidents graves, des blessures corporelles ou des dommages aux biens.

## STEP A-01

### ! UPDATES

Check [www.hbracing.com](http://www.hbracing.com) for the latest updates to the instructions.

Front  
Vorne  
Avant

2x Make 2  
2 Stück

Rear  
Hinten  
Arrière

2x Make 2  
2 Stück

Front Shock Set 204392  
Rear Shock Set 204393

#### SETUP SHEET

See Set-Up Sheet on Page 27 or [hbracing.com](http://hbracing.com)

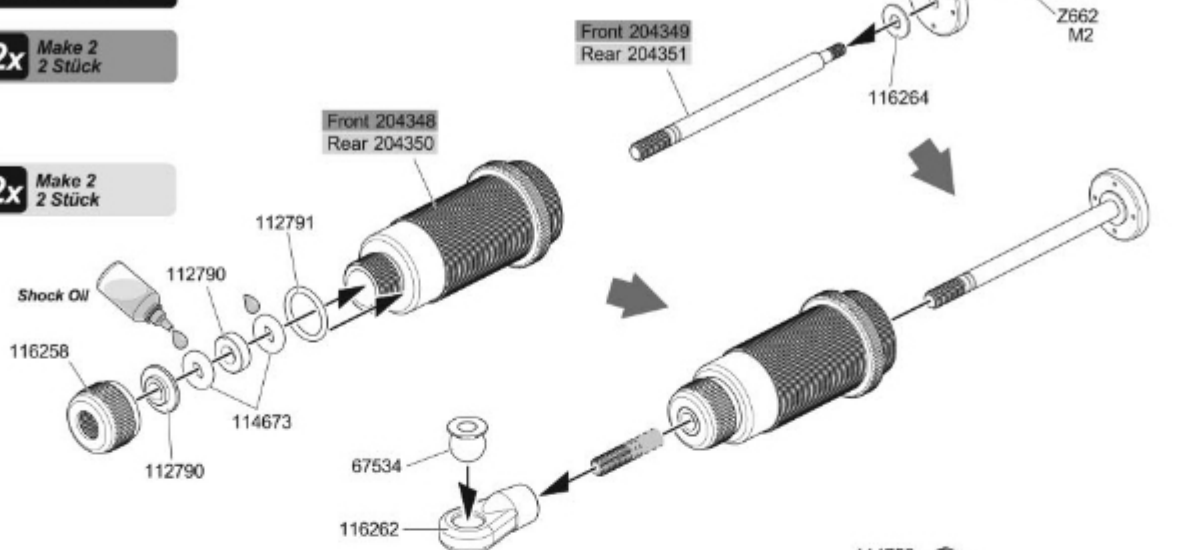

Move the shaft up and down slowly to remove all air bubbles.  
Bewegen Sie die Kolbenstange langsam nach oben und unten, damit Luftblasen entweichen können.  
Déplacez l'axe vers le haut et vers le bas doucement pour faire partir toutes les bulles.

#### SETUP SHEET

See Set-Up Sheet on Page 27 or [hbracing.com](http://hbracing.com)

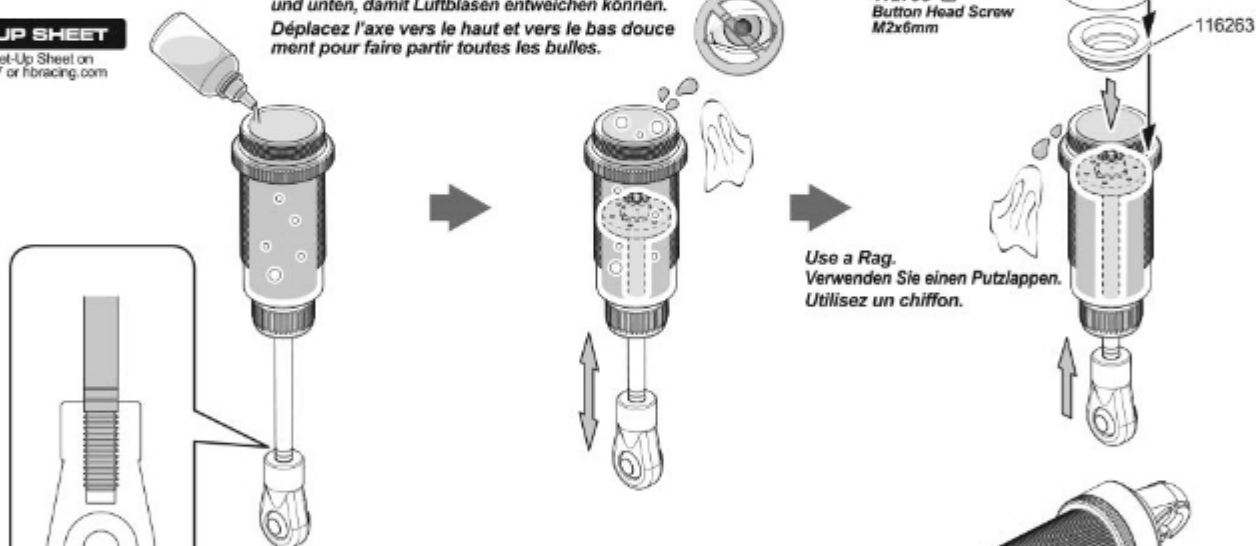

Use a Rag.  
Verwenden Sie einen Putzlappen.  
Utilisez un chiffon.

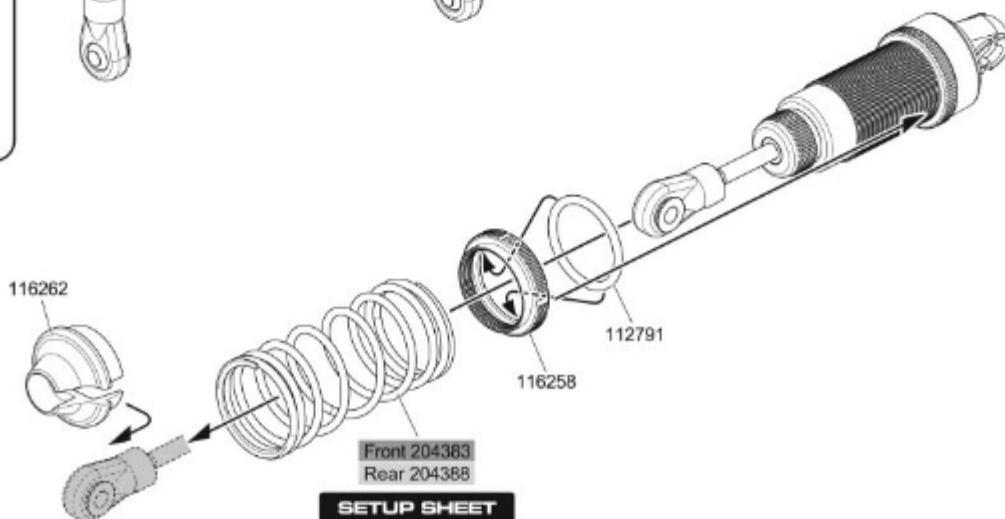

#### SETUP SHEET

See Set-Up Sheet on Page 27 or [hbracing.com](http://hbracing.com)

## STEP B-01

Front  
Vorne  
Avant

**1x** Make 1  
1 Stück 1 fois

Rear  
Hinten  
Arrière

**1x** Make 1  
1 Stück 1 fois

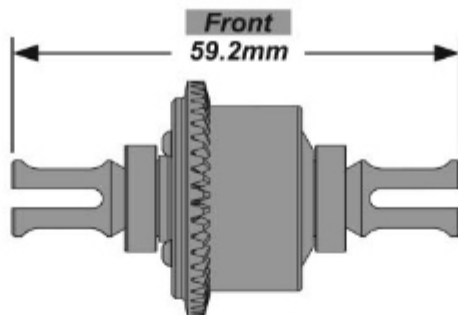

Front Complete Diff 112782

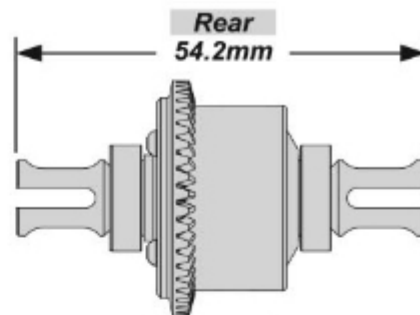

Rear Complete Diff 112783

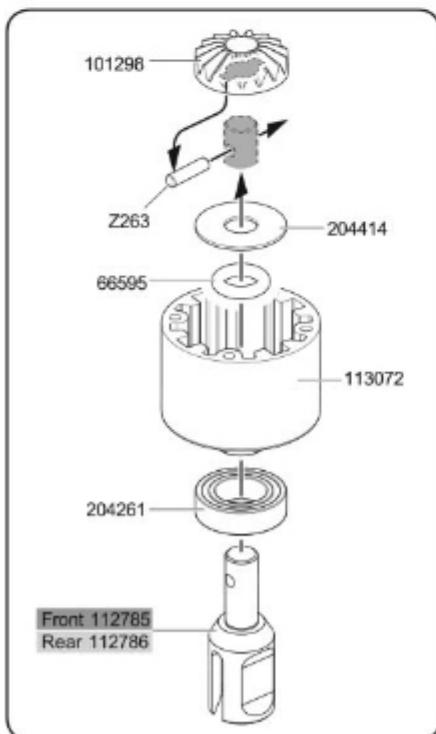
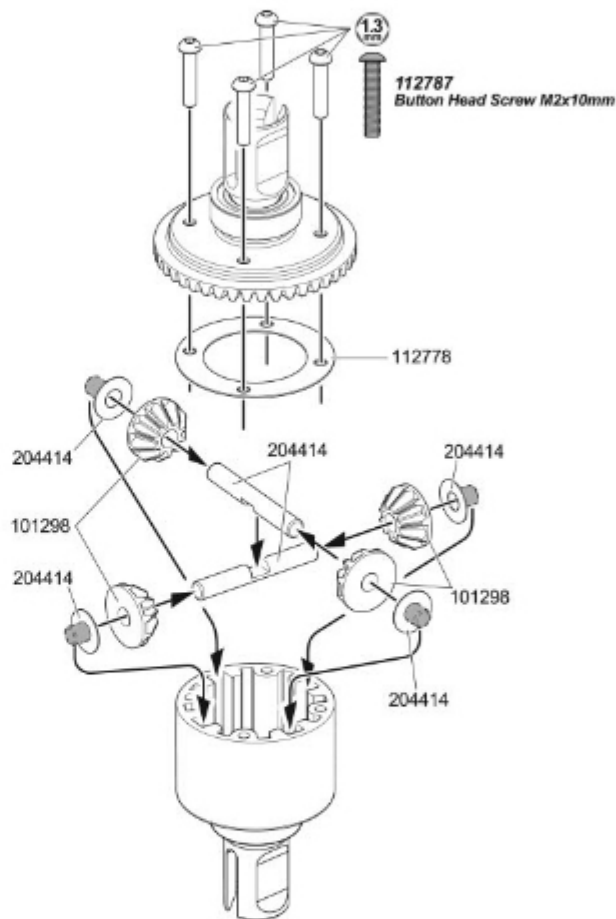
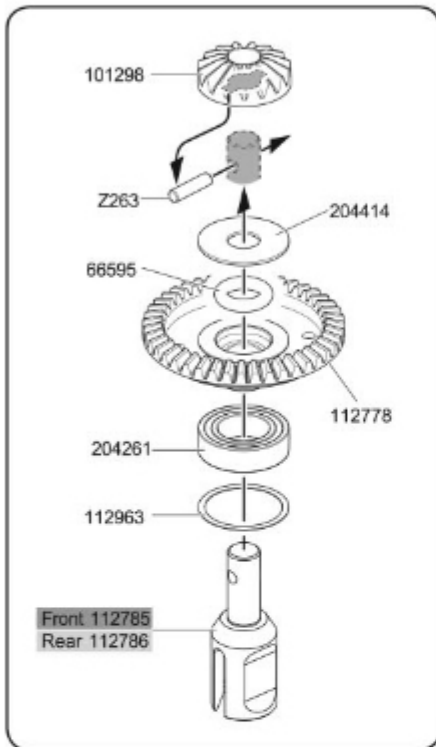

### SETUP SHEET

See Set-Up Sheet on  
Page 27 of fbracing.com

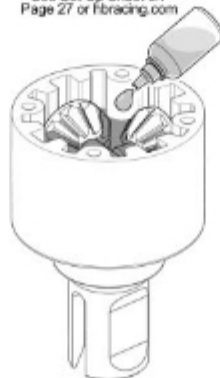

**#10,000**

**Front**  
Vorne  
Avant

ORI44422  
Silicone Oil #10,000  
Silikon Daempferoel #10,000  
Huile silicone 10,000

**#10,000**

**Rear**  
Hinten  
Arrière

ORI44422  
Silicone Oil #10,000  
Silikon Daempferoel #10,000  
Huile silicone 10,000

Fill to top of cross shafts with silicone diff oil.  
Füllen Sie das Gehäuse bis zum Wellenkreuz  
mit Silikon-Differential-Öl.  
Remplissez d'huile jusqu'en haut des arbres  
trans-versaux avec de l'huile silicone pour différentiel.

## STEP B-02

**Center**  
**Mitte**  
**central**

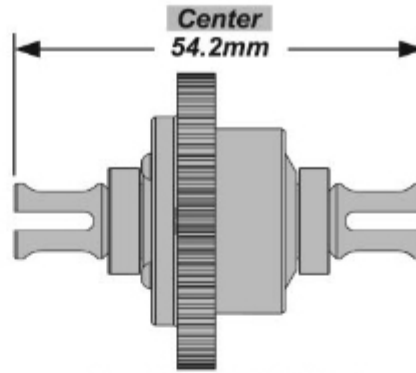
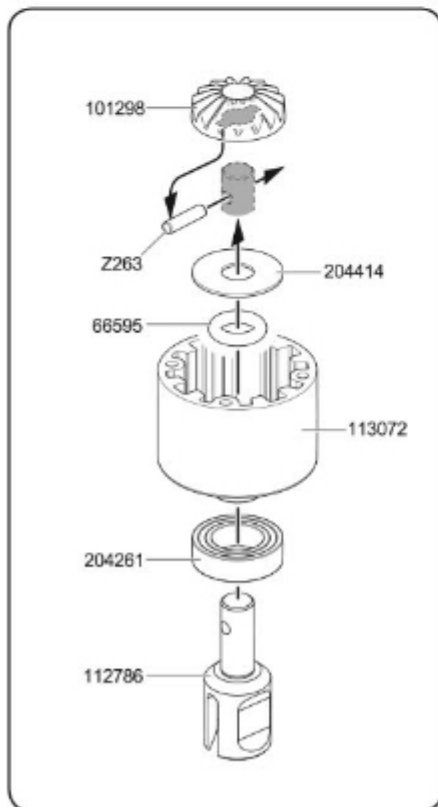
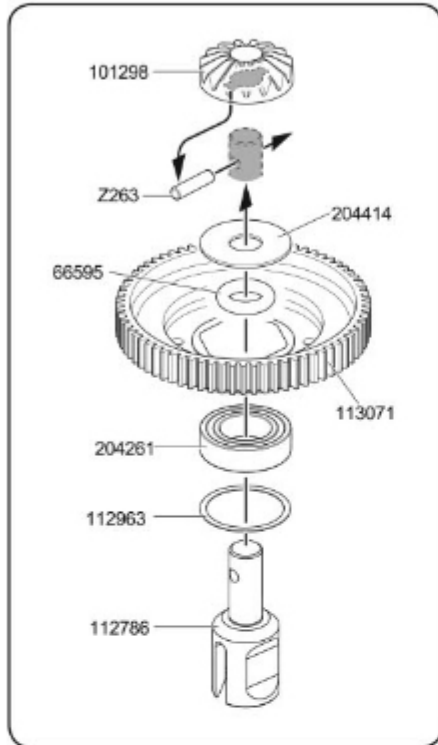

**Center Complete Diff** 112784

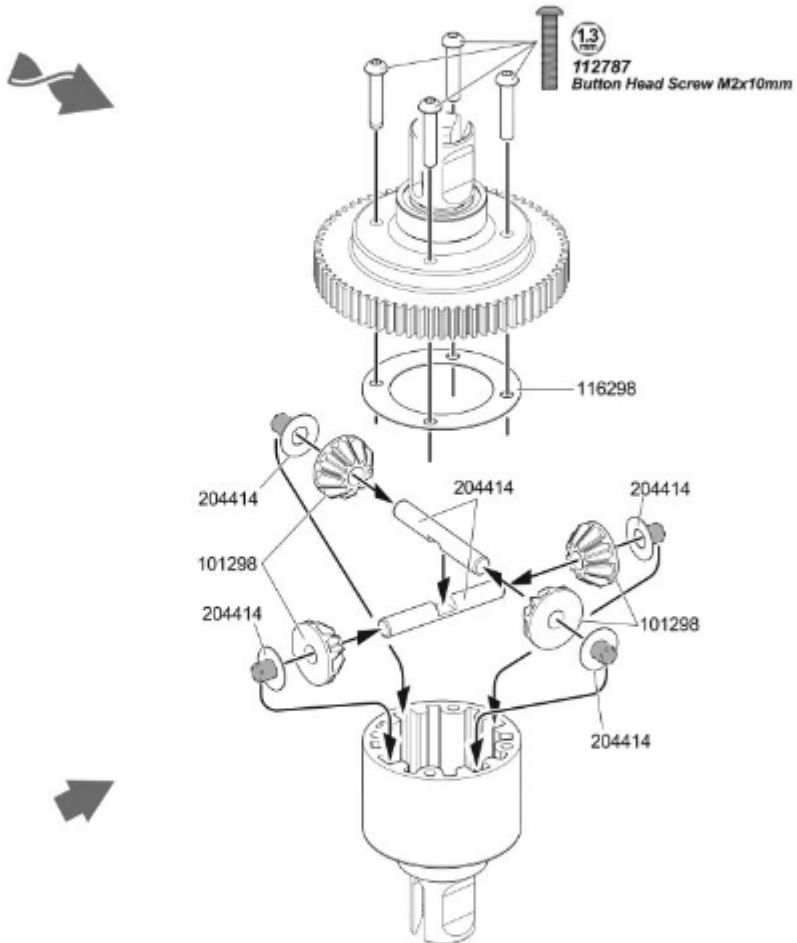

### SETUP SHEET

See Set-Up Sheet on  
Page 27 or fbracing.com

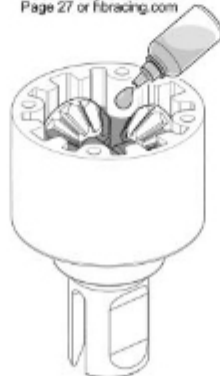

**#100,000**

**Center**  
**Mitte**  
**central**

ORI44427  
Silicone Oil #100,000  
Silikon Daempferoel #100,000  
Huile silicone 100,000

Fill to top of cross shafts with silicone diff oil.  
Füllen Sie das Gehäuse bis zum Wellenkreuz  
mit Silikon-Differential-Öl.  
Remplissez d'huile jusqu'en haut des arbres  
trans-versaux avec de l'huile silicone pour différentiel.



## STEP C-01

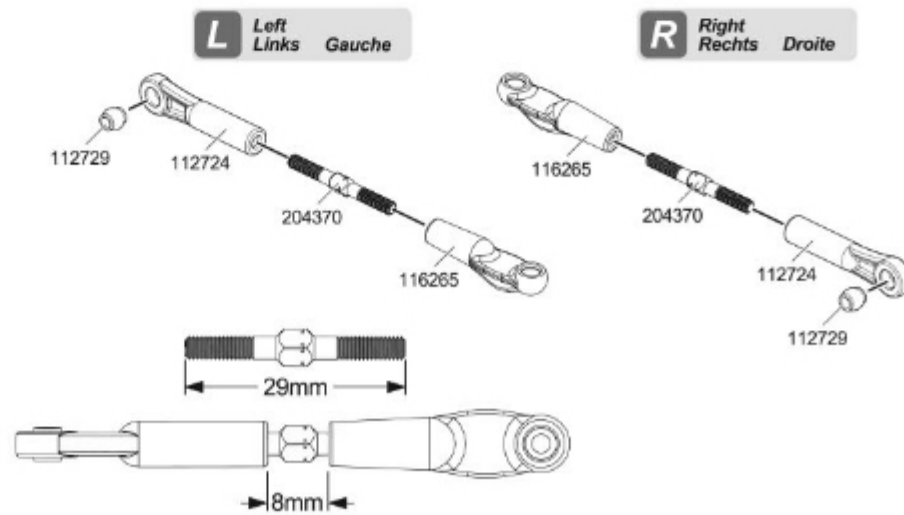
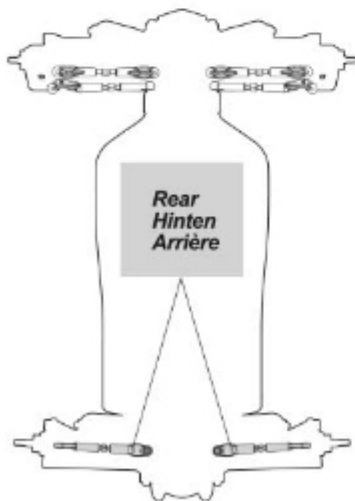
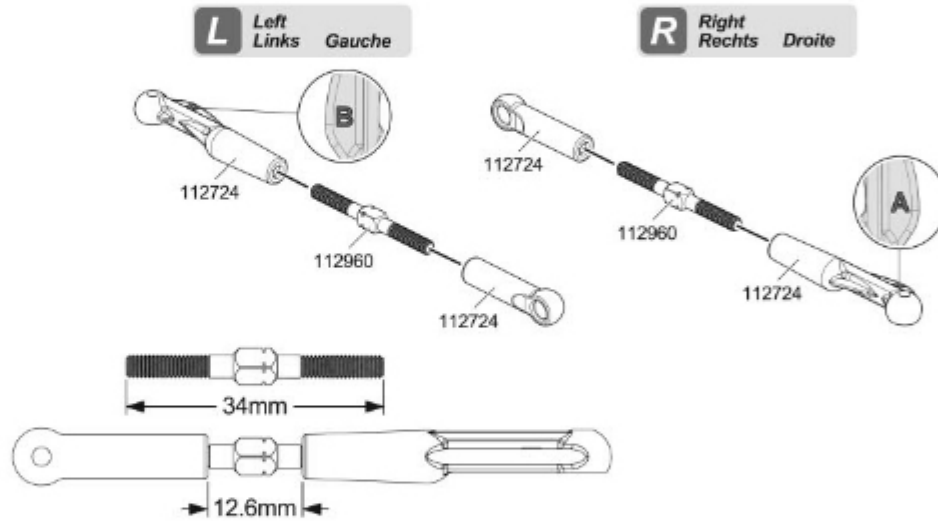
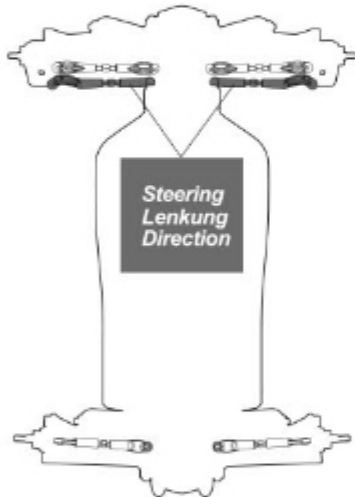
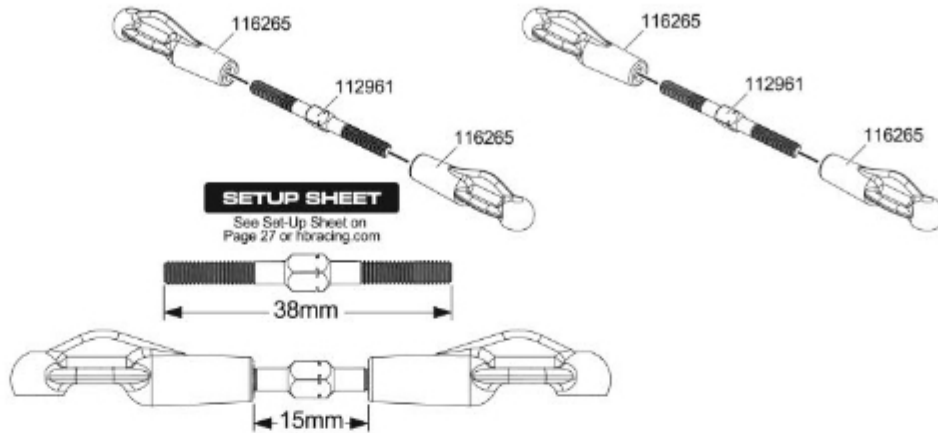
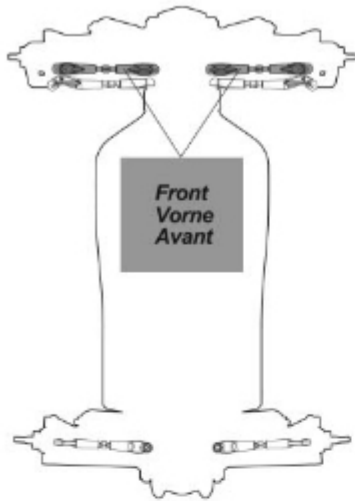

# BAG-D

## STEP D-01

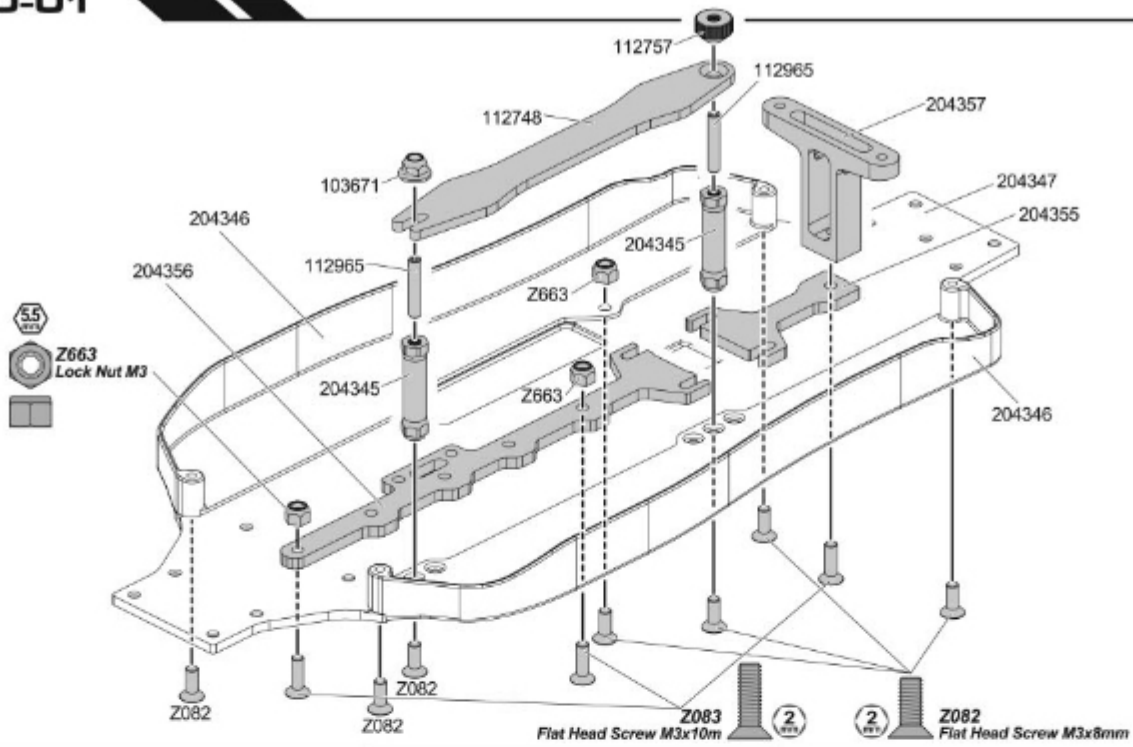

# BAG-E

## STEP E-01

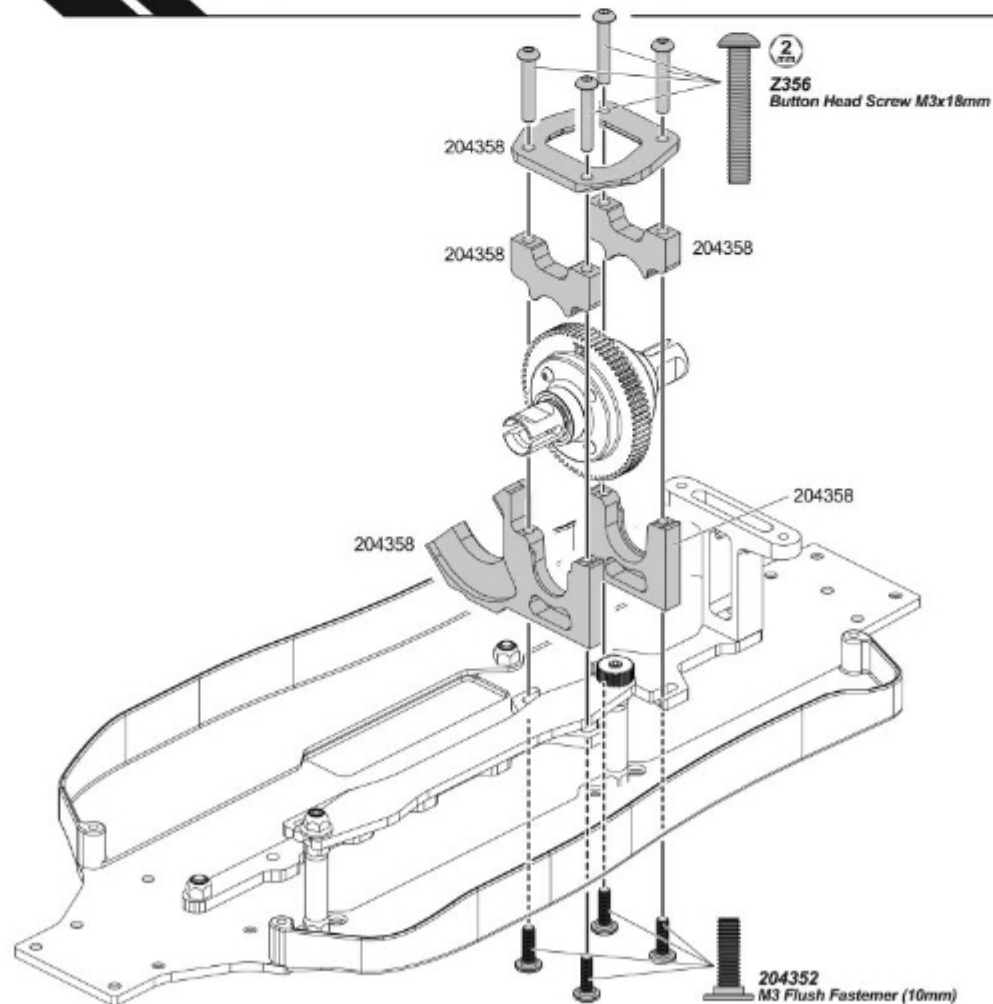

## STEP F-01

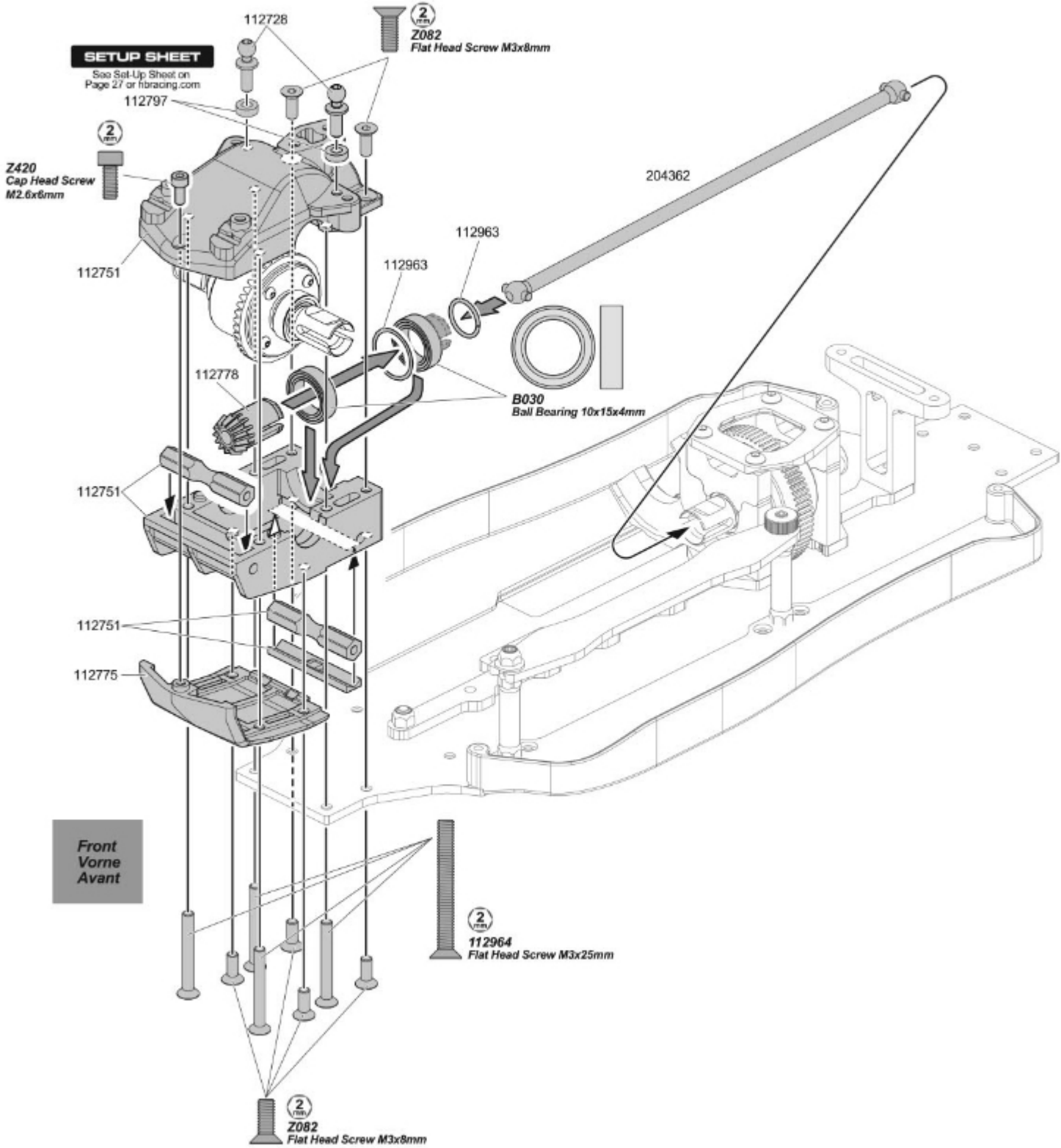

## STEP F-02

### SETUP SHEET

See Set-Up Sheet on  
Page 27 or hbraing.com

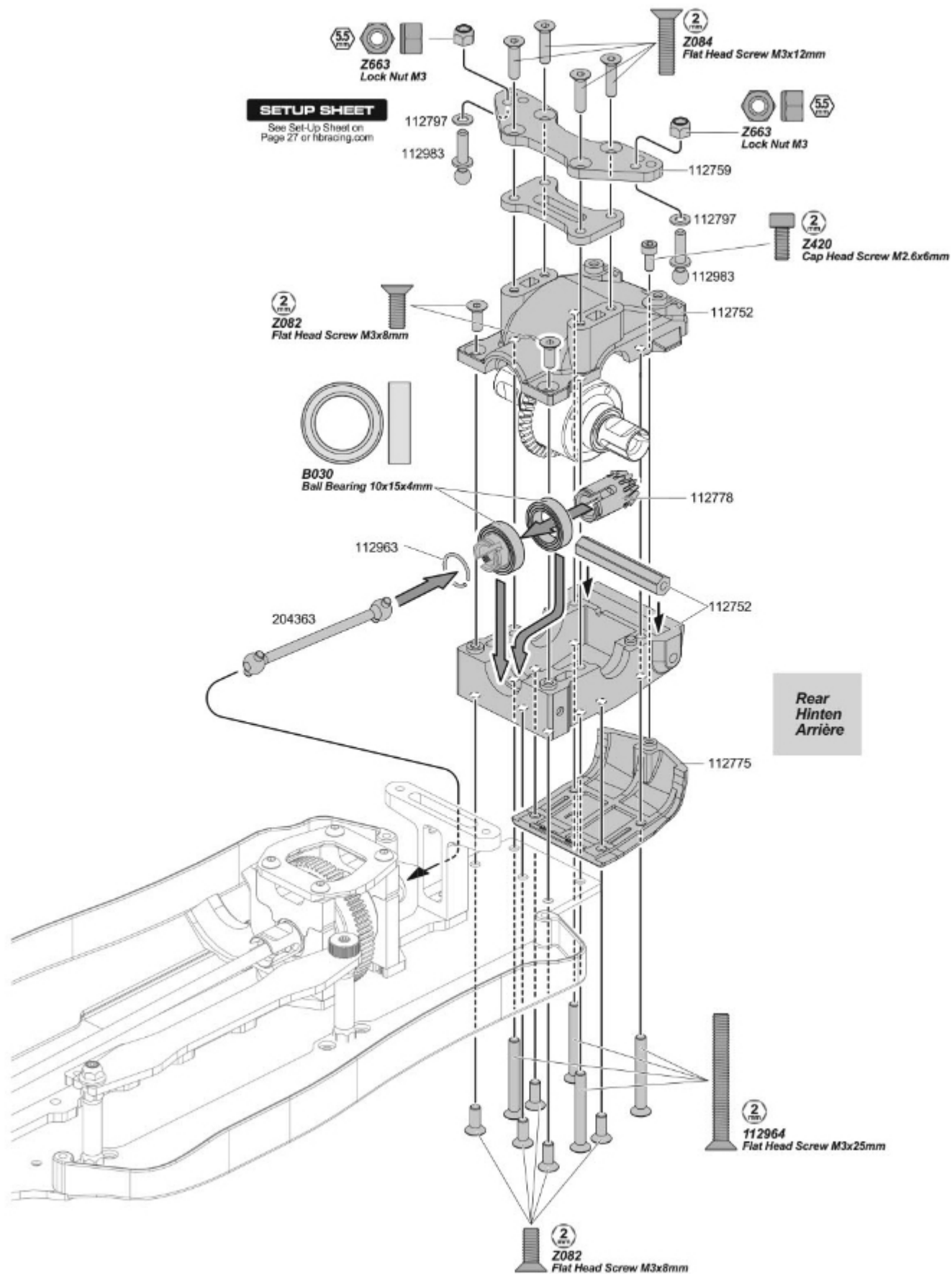

## STEP G-01

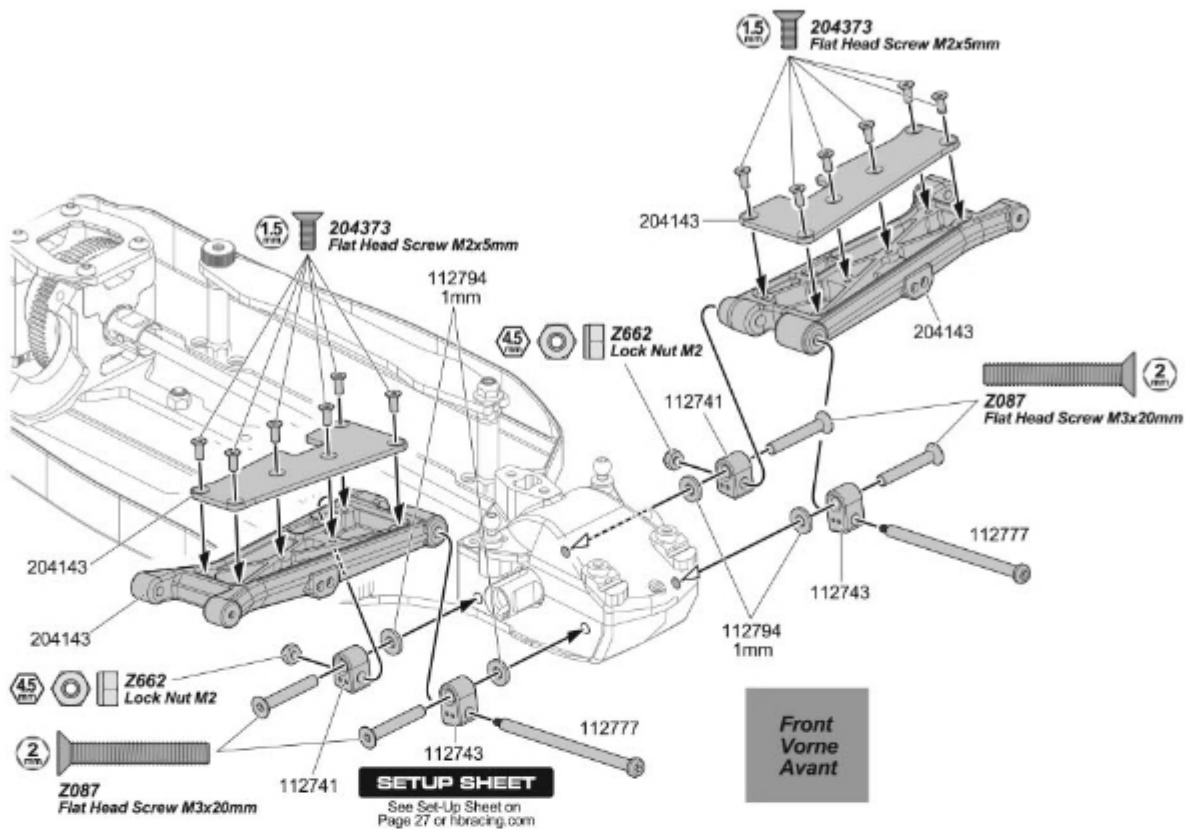

## STEP G-02

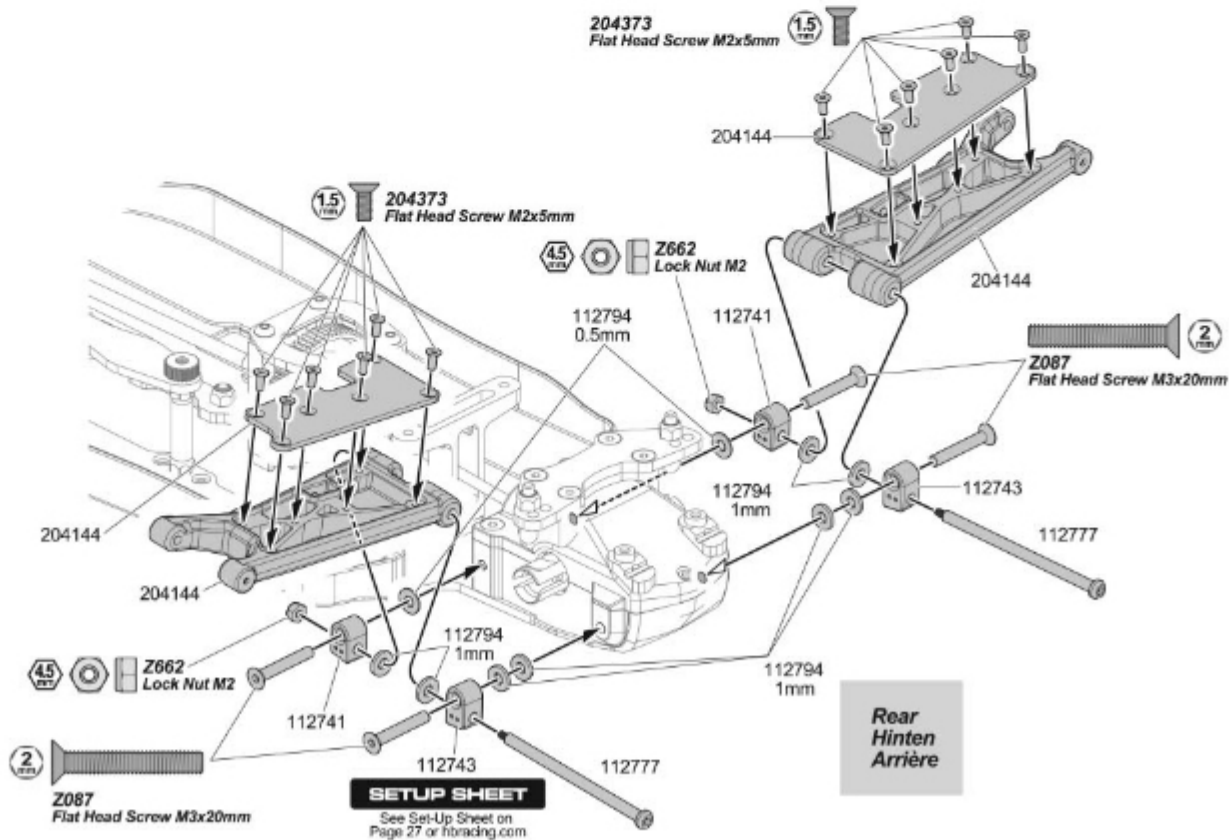

## STEP H-01

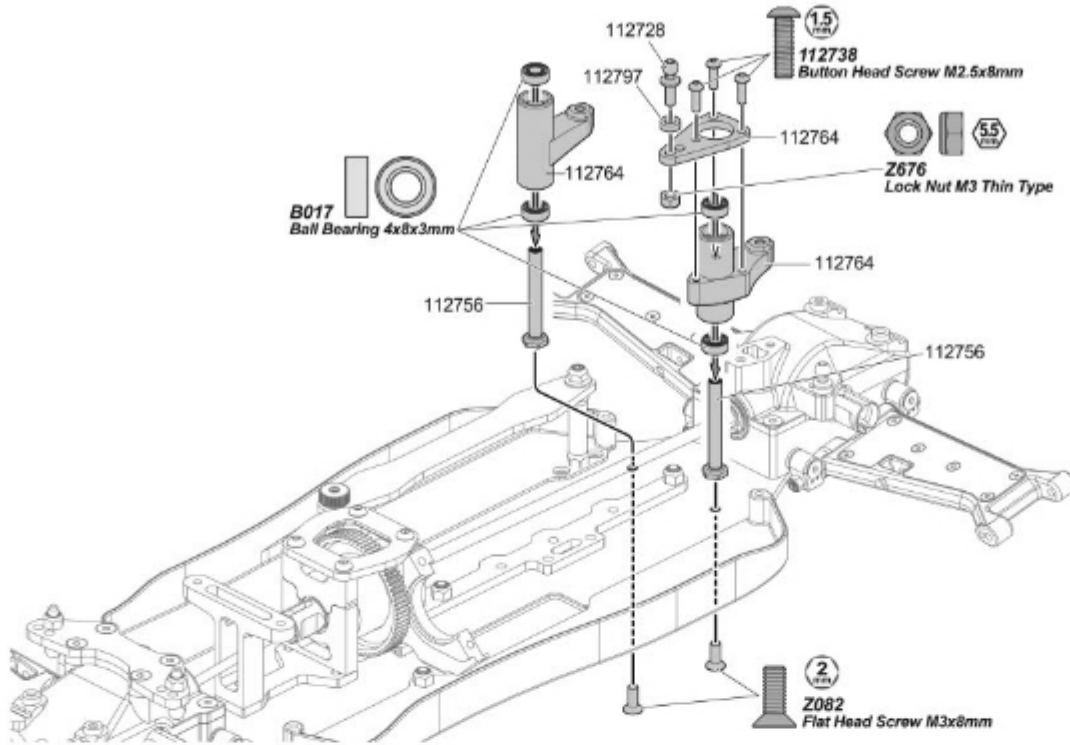

## STEP H-02

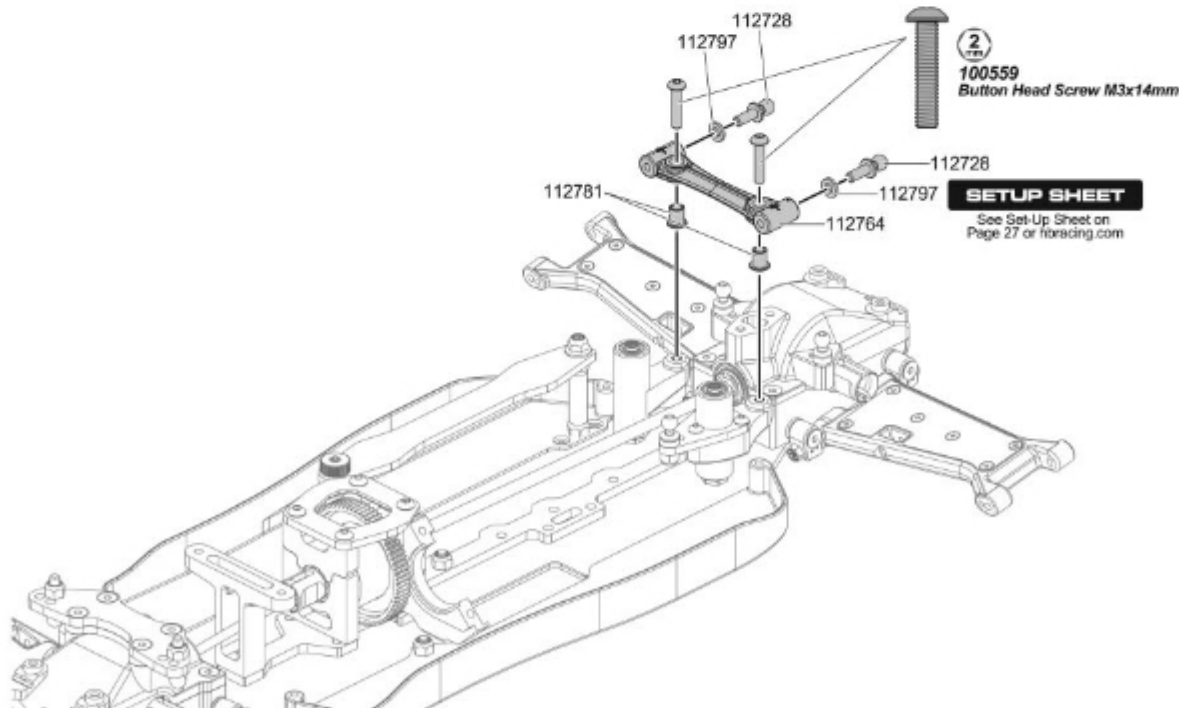

## STEP I-01

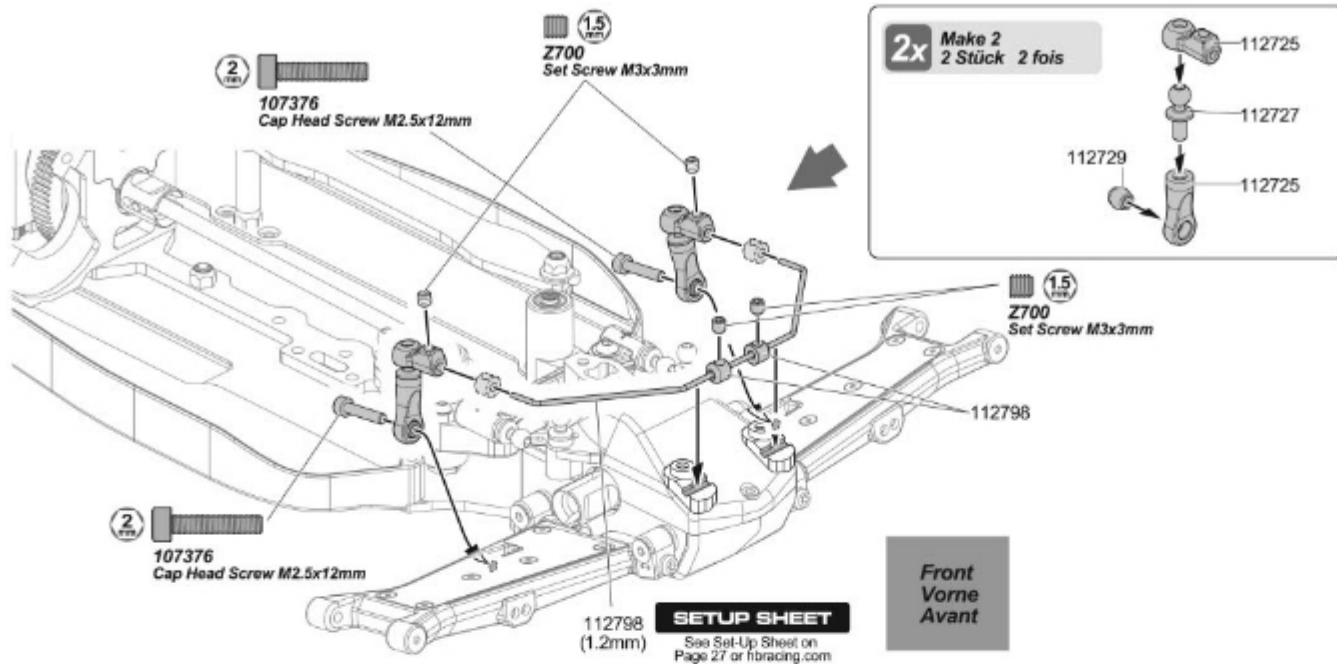

## STEP I-02

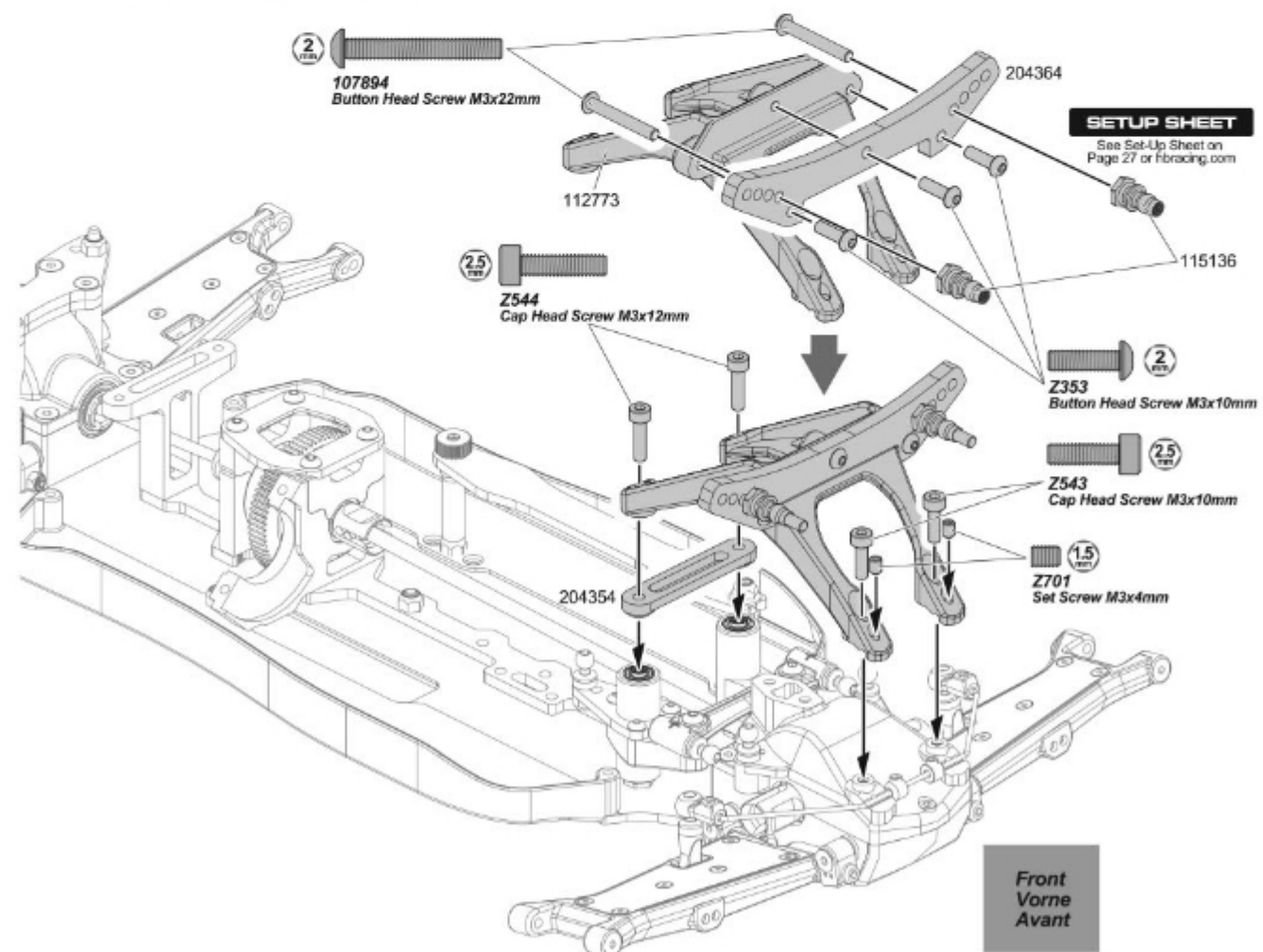

# BAG-I

## STEP I-03

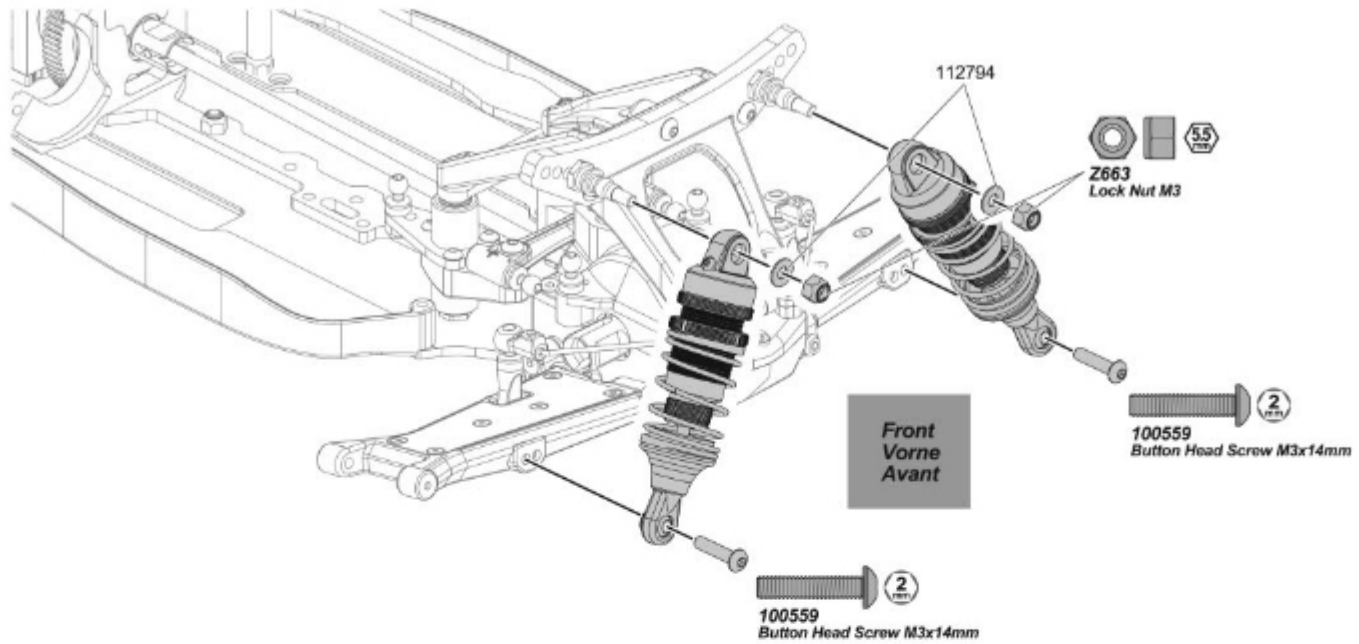

# BAG-J

## STEP J-01

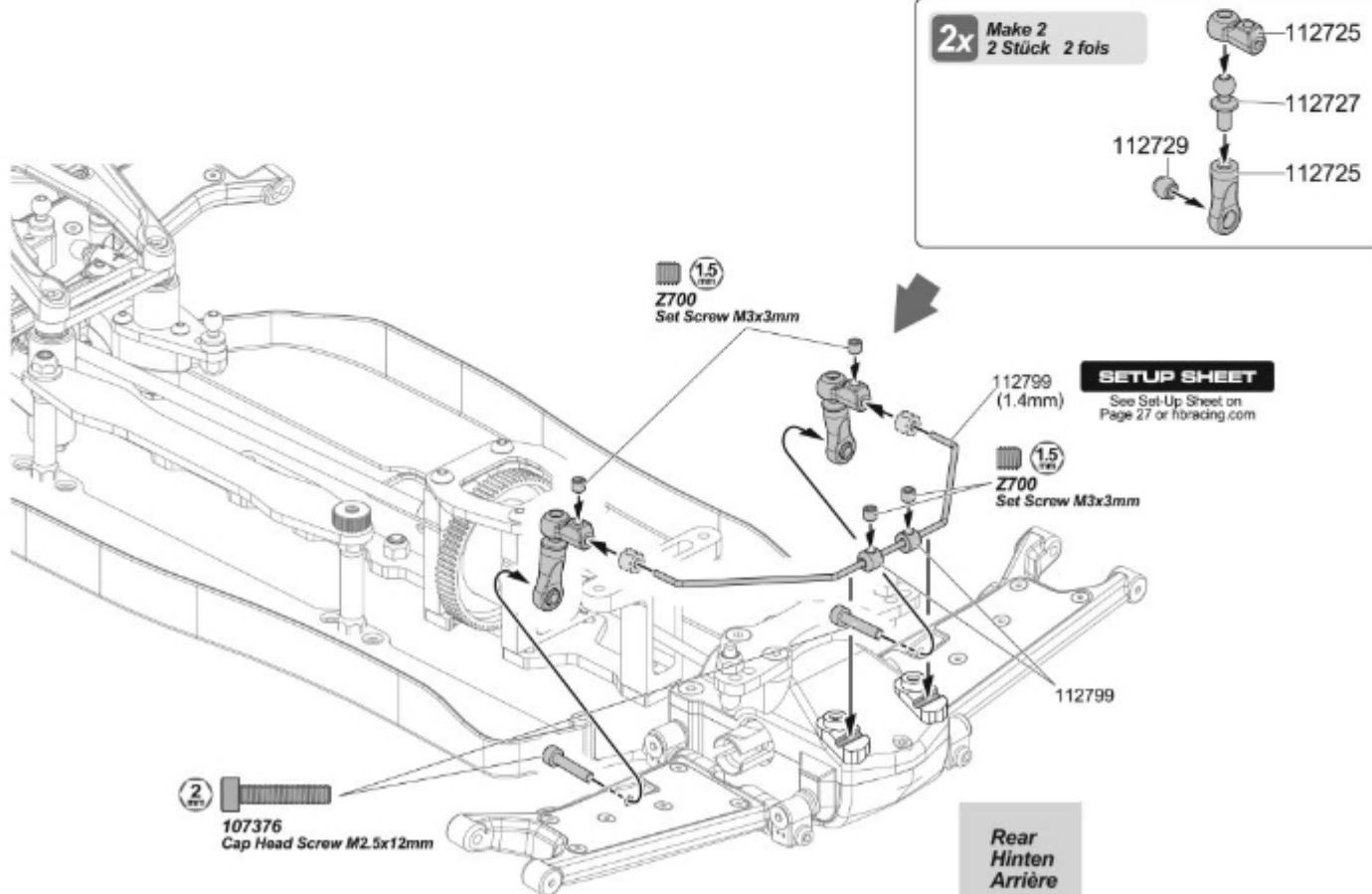



## STEP J-02

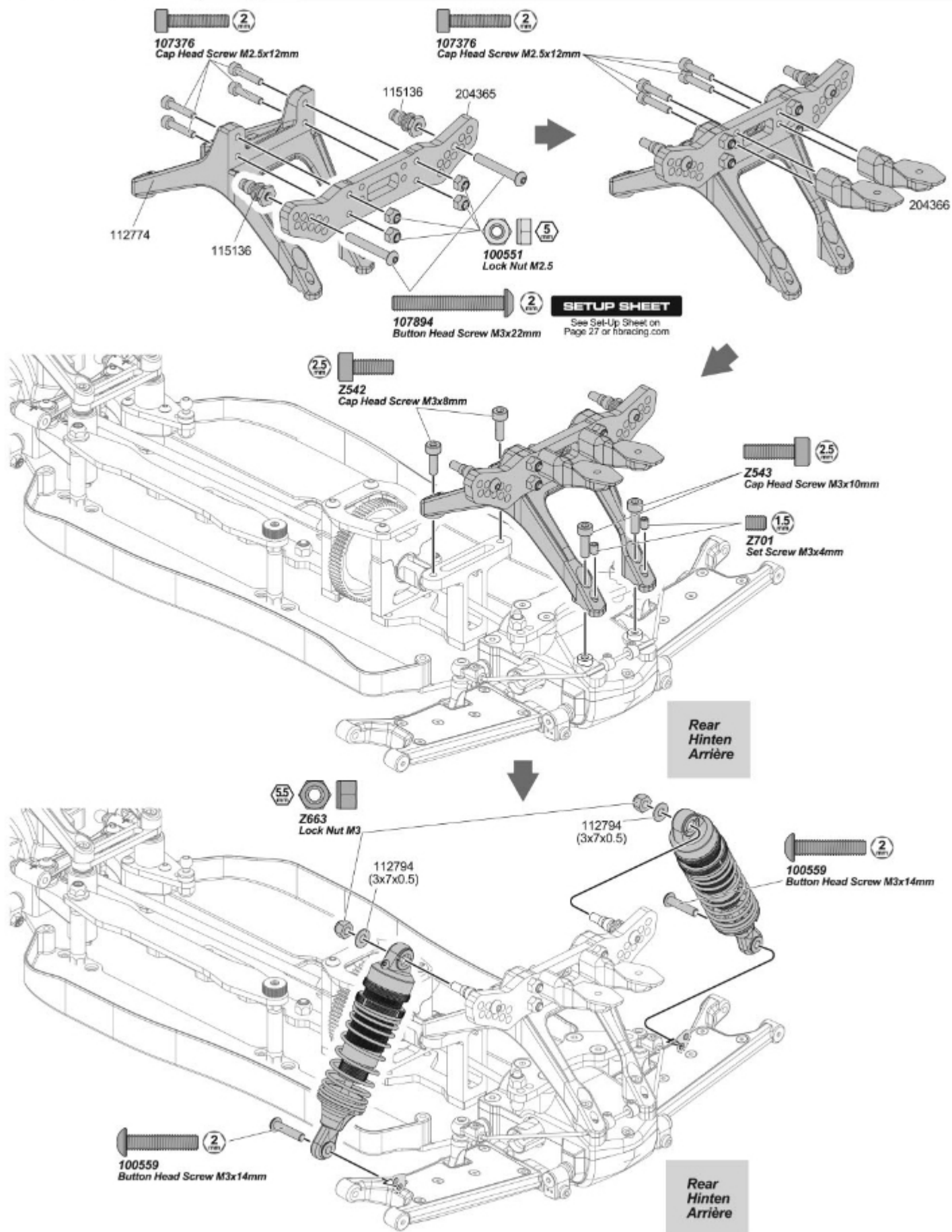

## STEP K-01

Front  
Vorne  
Avant

### SETUP SHEET

See Set-Up Sheet on  
Page 27 or hbracing.com

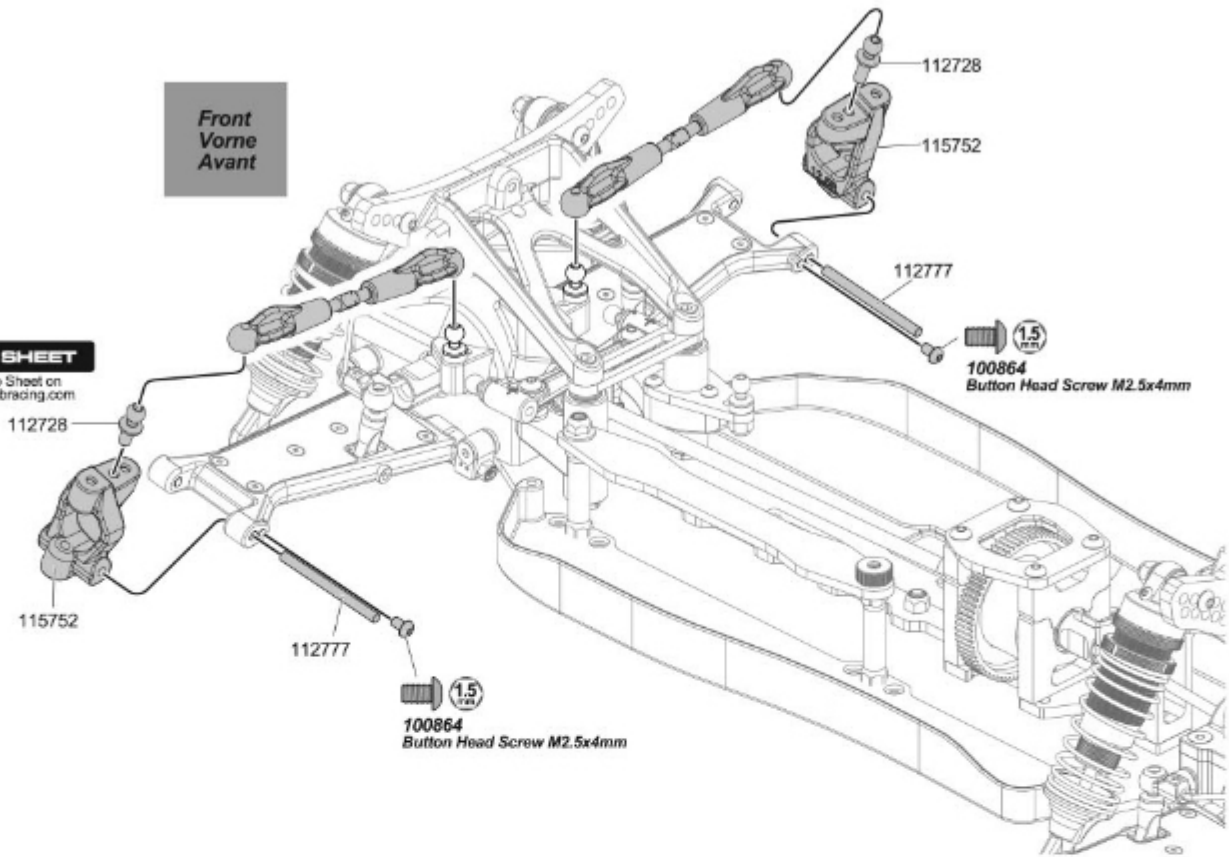

## STEP K-02

**2x** Make 2  
2 Stück 2 fois

**Front Drive Shaft Set 75mm** 112730

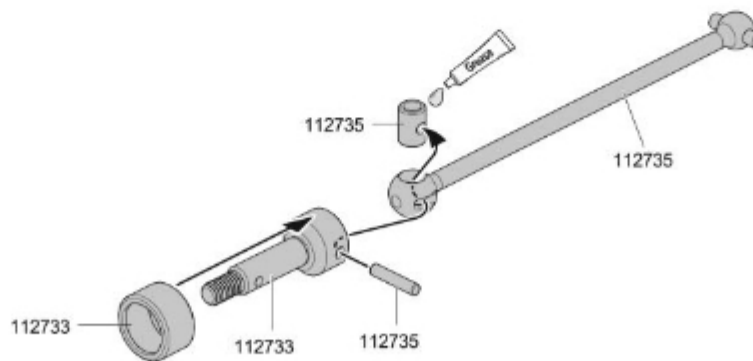



## STEP K-04

**2x** Make 2  
2 Stück 2 fois

**Rear Drive Shaft Set 73mm** 112731

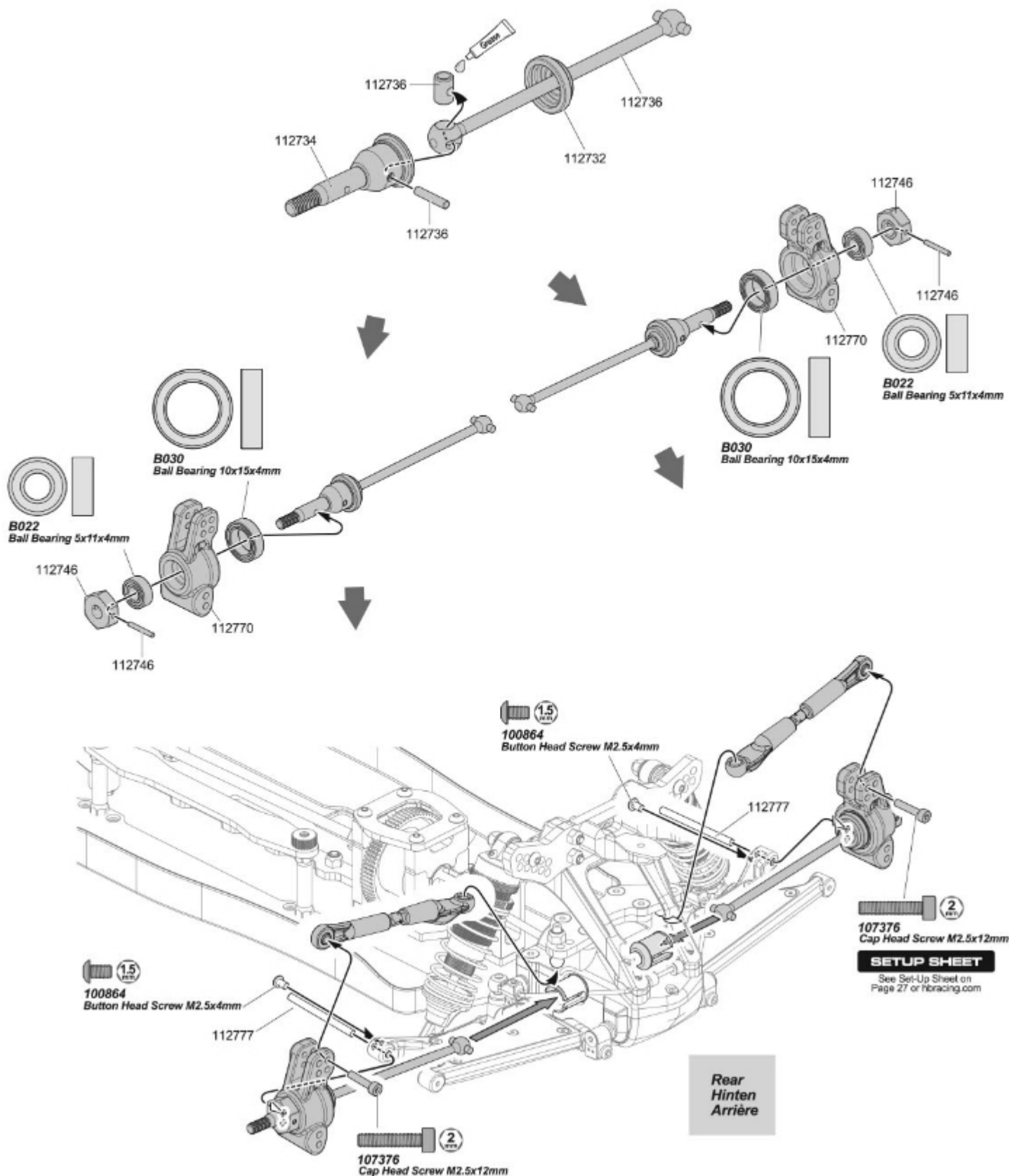

## STEP L-01

HB204262 ALUM STEERING SERVO HORN (25) V2 Futaba  
 HB204263 ALUM STEERING SERVO HORN (23) V2 KO \*Option Part

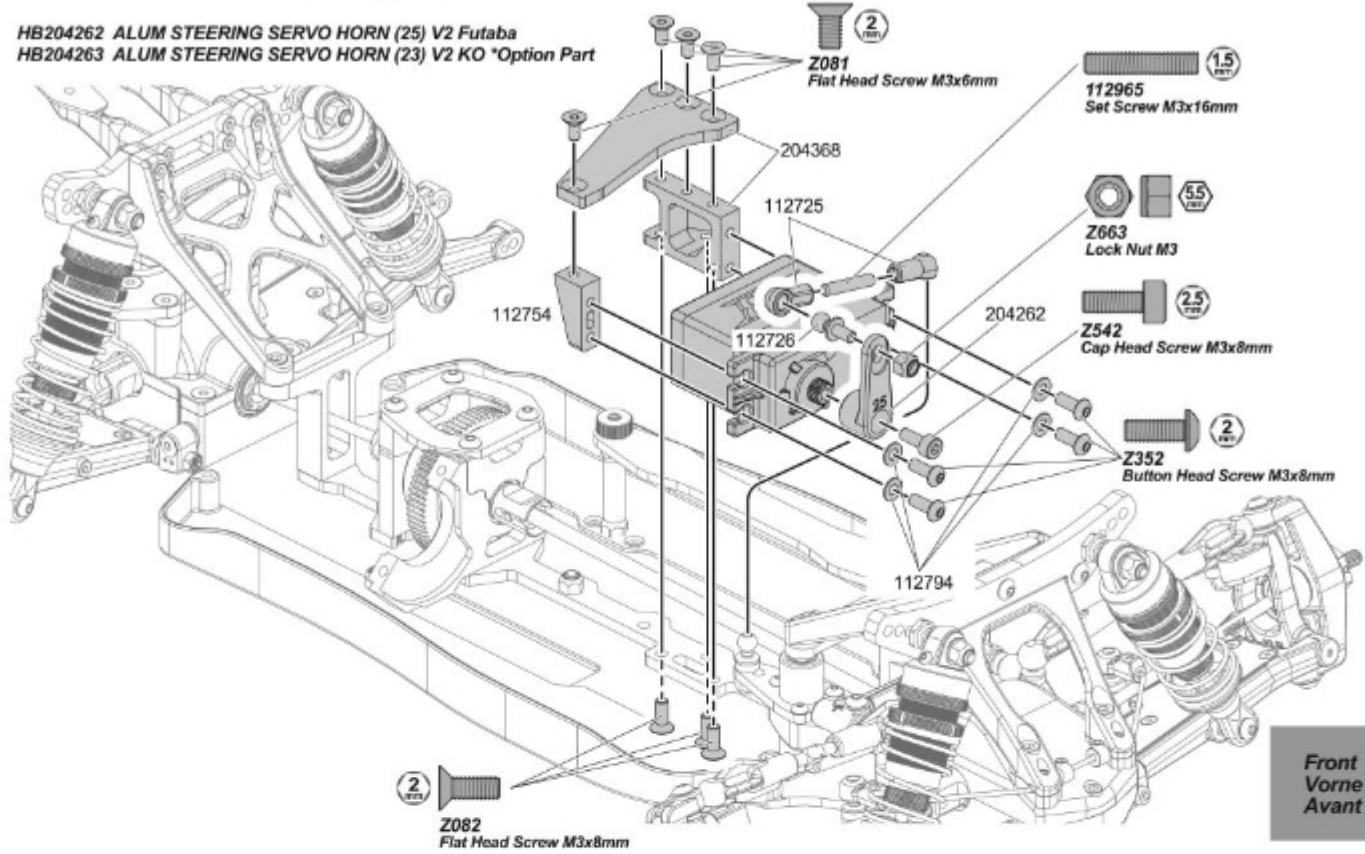

## STEP L-02

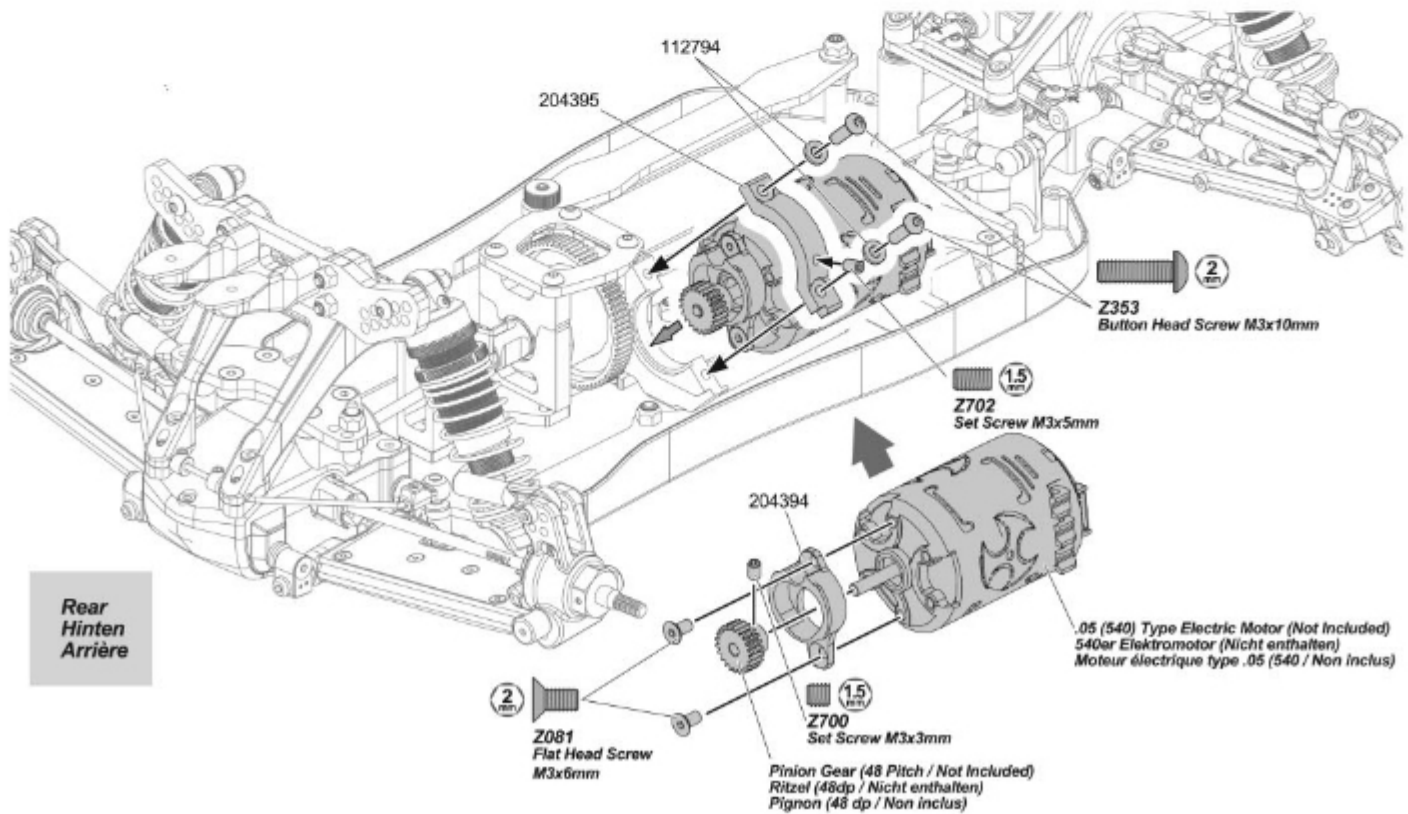

## STEP L-03

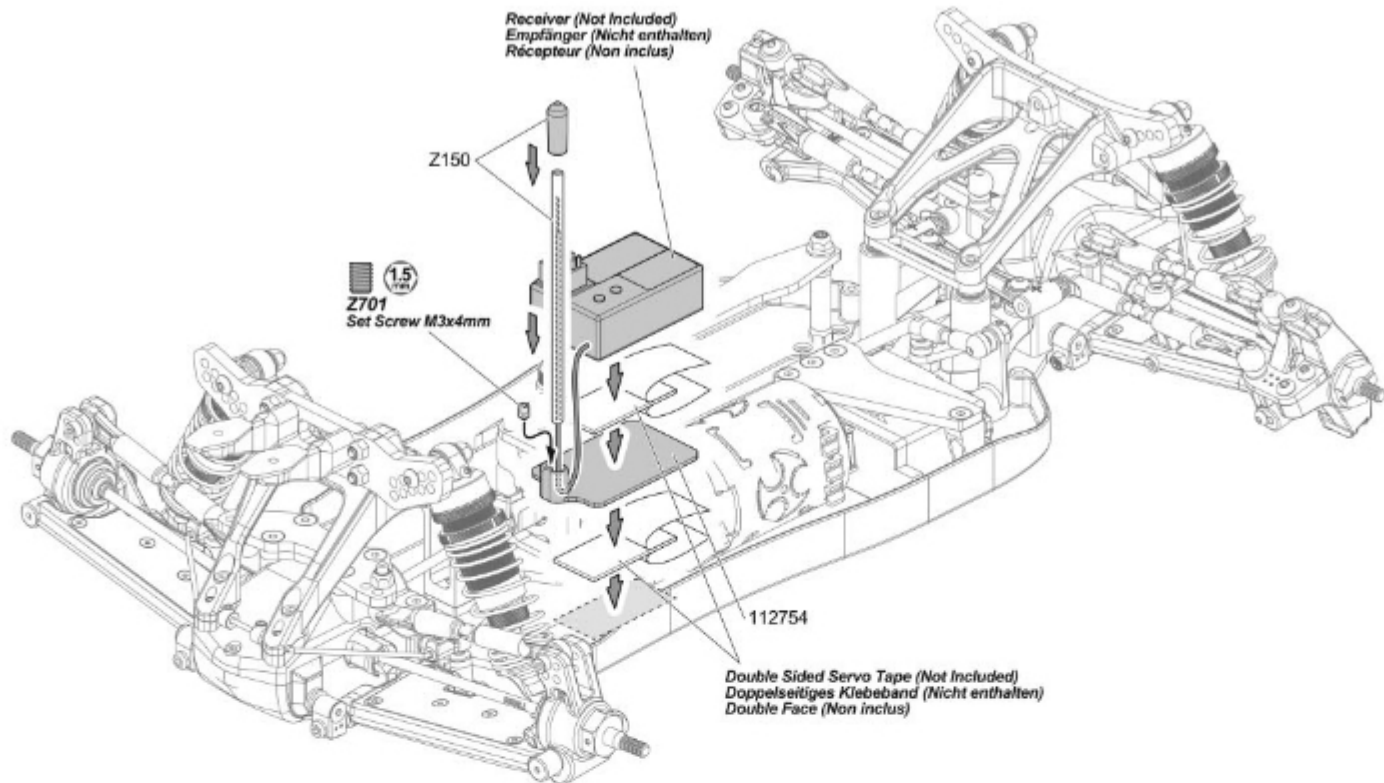

## STEP L-04

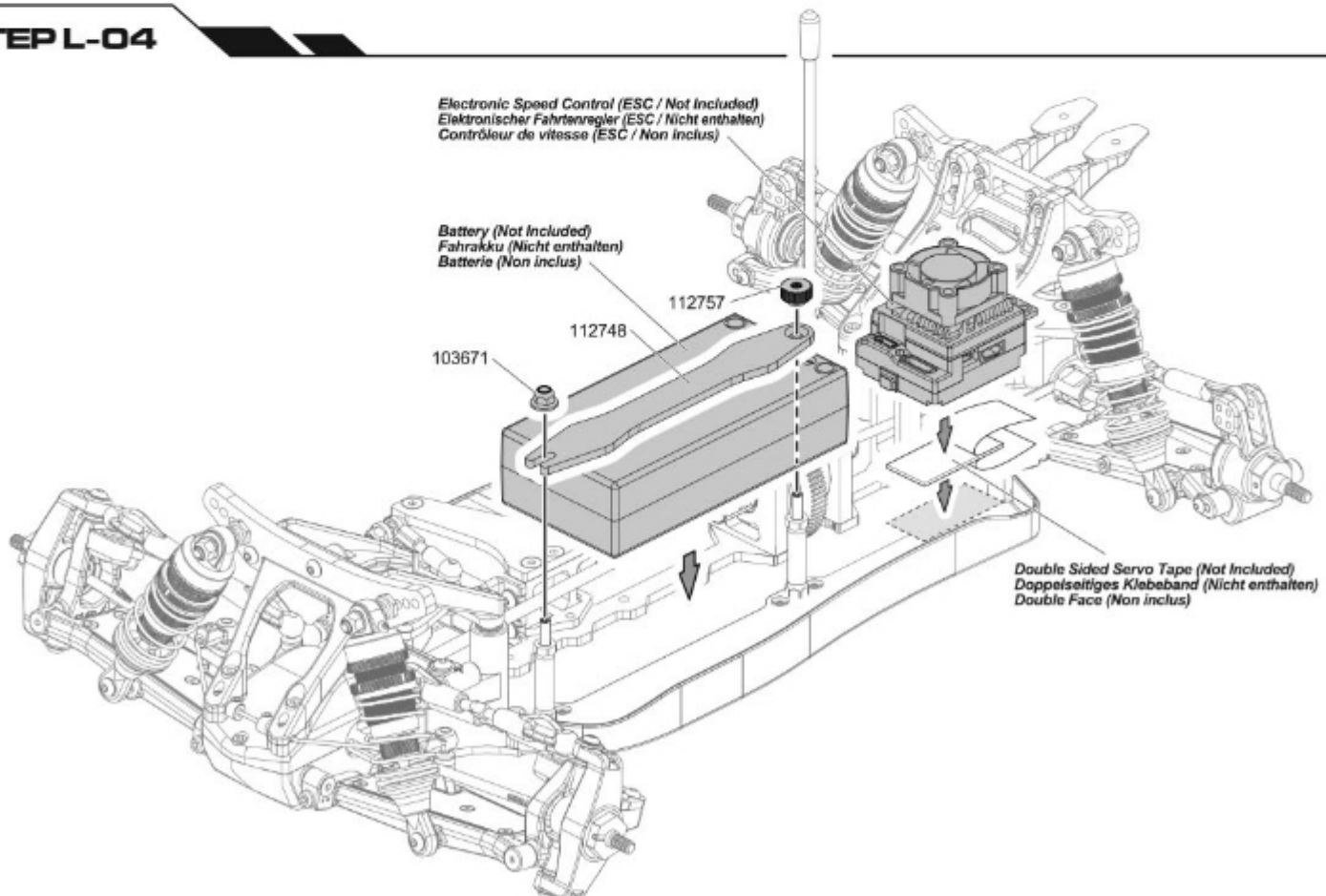

# BAG-L

## STEP L-05

Tires (Not Included)  
Reifen (Nicht enthalten)  
Pneus (Non inclus)

61094

61094

61094

61094

# BAG-M

## STEP M-01

Paint from inside using polycarbonate paint.  
Lackieren Sie von Innen mit Farben für Polycarbonat.  
Peignez à partir de l'intérieur, en utilisant une peinture polycarbonate.

Remove protective film before using.  
Entfernen Sie vor dem Fahren die Schutzfolie.  
Retirez le film de protection avant utilisation.

204375

Make a hole  
Bohren Sie ein Loch.  
Faites un trou

204374

Hobby Knife  
Modellbaumesser  
Couteau de modélisme

204413  
Velcro  
Klettband  
Velcro

## STEP M-02

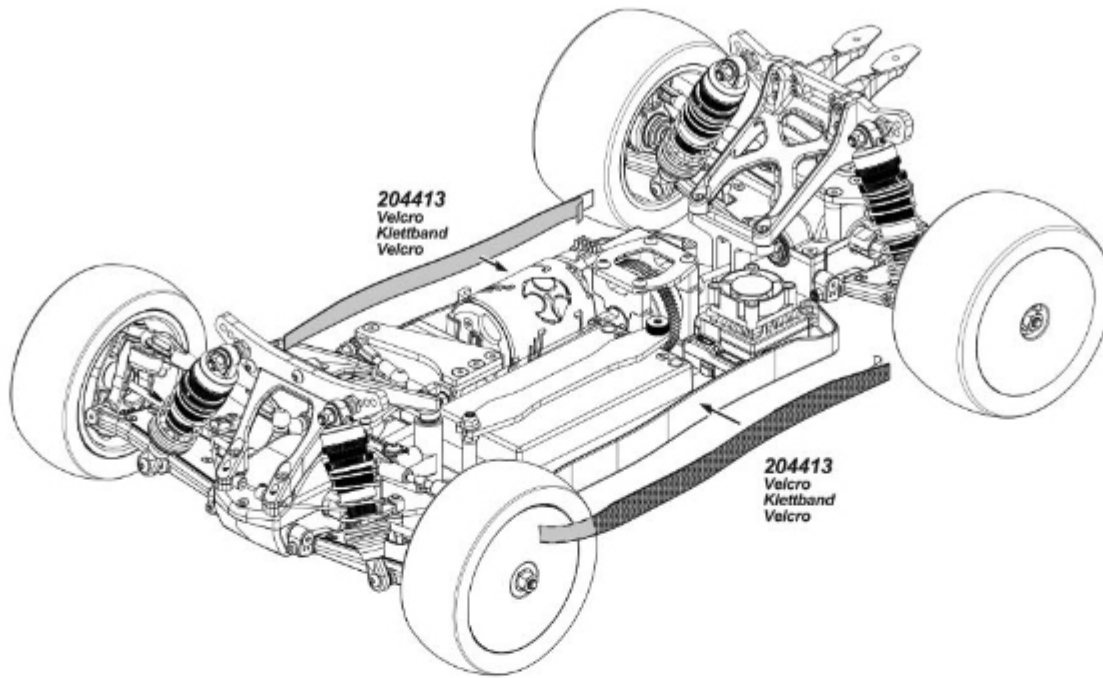

## STEP M-03

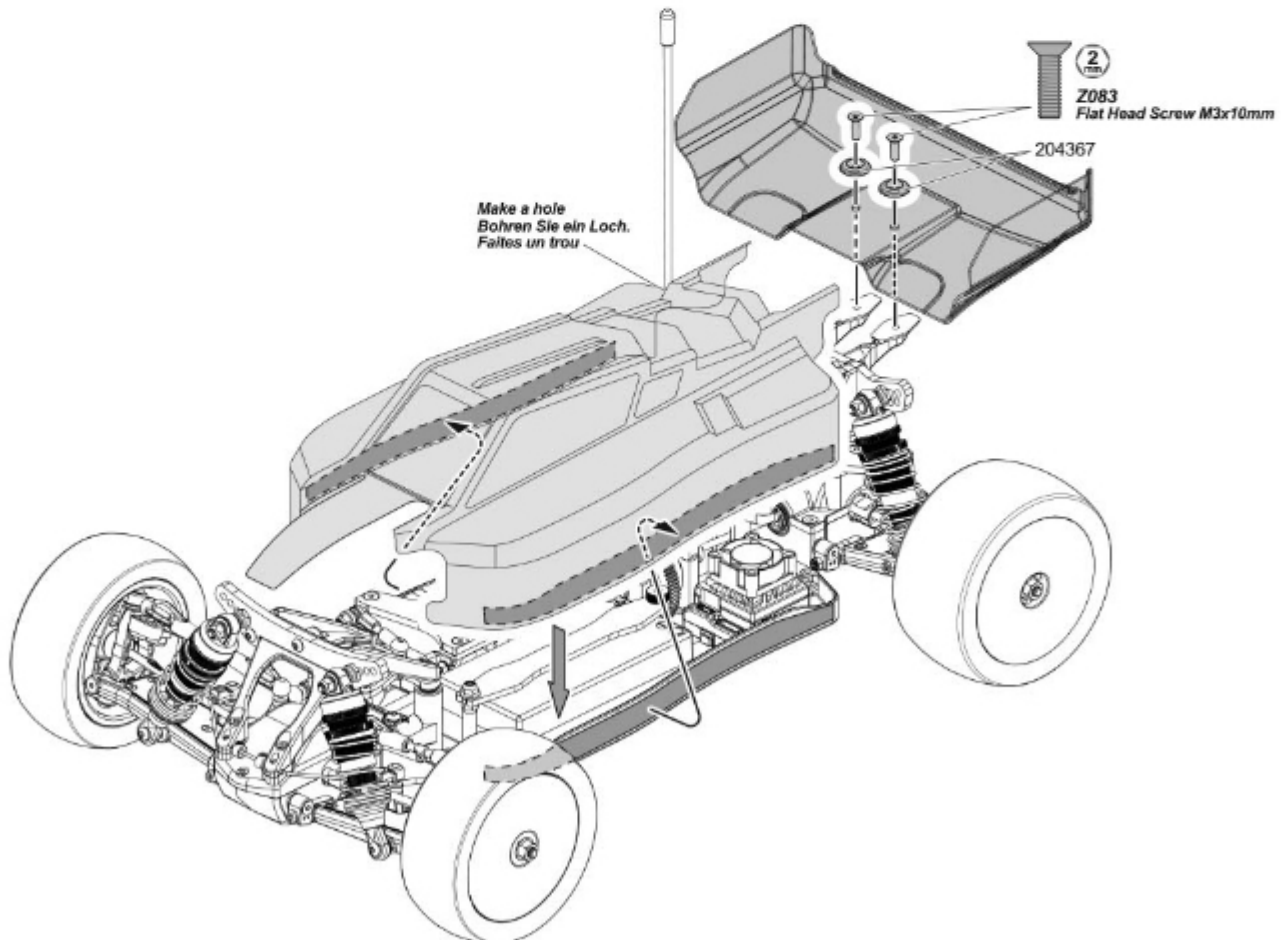



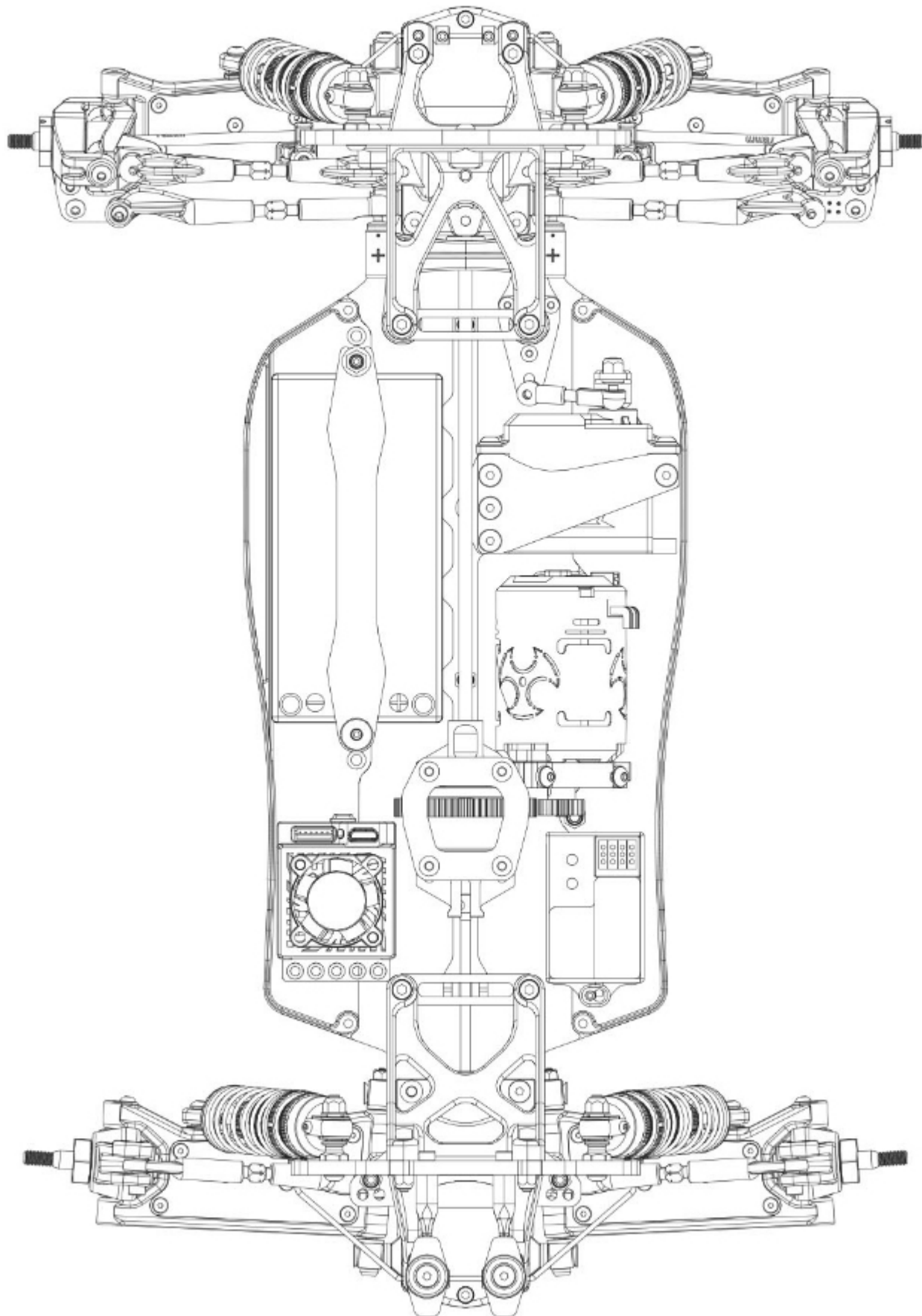

Driver \_\_\_\_\_ Date \_\_\_\_\_ Track \_\_\_\_\_ Event \_\_\_\_\_

Track Condition \_\_\_\_\_

## FRONT

### FRONT KICK-UP



Front/Front	Front/Rear	Kick-up
•	•	10°
••	•	9°
•••	•	8°
•	••	11°
••	••	10°
•••	••	9°
•	•••	12°
••	•••	11°
•••	•••	10°

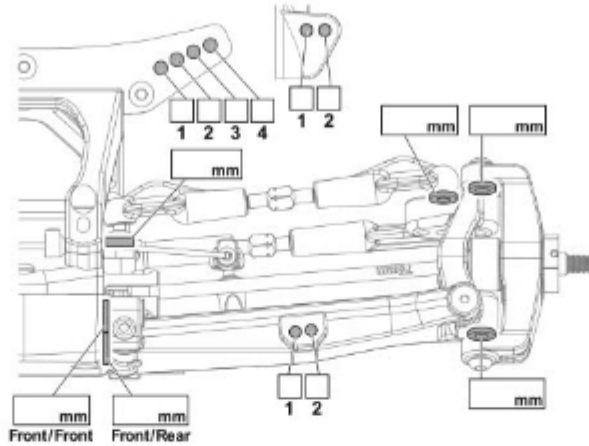

### FRONT SHOCKS

Oil wt. \_\_\_\_\_  
 Piston \_\_\_\_\_  
 Spring \_\_\_\_\_  
 Notes \_\_\_\_\_

Ride Height \_\_\_\_\_ mm  
 Camber Angle \_\_\_\_\_ °  
 Toe Angle \_\_\_\_\_ °  
 Sway Bar \_\_\_\_\_ mm  
 Shock Length \_\_\_\_\_ mm



## REAR

### REAR ANTI-SQUAT



Rear/Front	Rear/Rear	Anti-squat
•	•	0°
•	••	1°
•	•••	2°
••	••	0°
••	•••	1°
•••	•••	0°

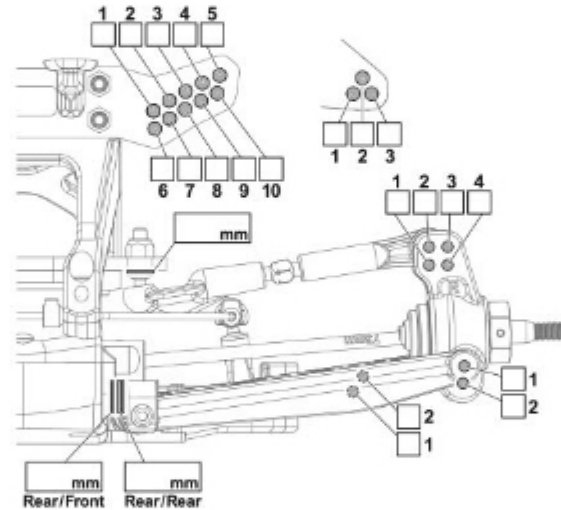

### REAR SHOCKS

Oil wt. \_\_\_\_\_  
 Piston \_\_\_\_\_  
 Spring \_\_\_\_\_  
 Notes \_\_\_\_\_

Ride Height \_\_\_\_\_ mm  
 Camber Angle \_\_\_\_\_ °  
 Toe Angle \_\_\_\_\_ °  
 Sway Bar \_\_\_\_\_ mm  
 Shock Length \_\_\_\_\_ mm



### TIRES

	Front	Rear
Tire	_____	_____
Insert	_____	_____

Battery \_\_\_\_\_  
 Motor \_\_\_\_\_  
 Gearing \_\_\_\_\_ / \_\_\_\_\_  
 Body / Wing \_\_\_\_\_ / \_\_\_\_\_

### DIFF OIL

	Front	Center	Rear
Brand	_____	_____	_____
Oil wt.	_____	_____	_____

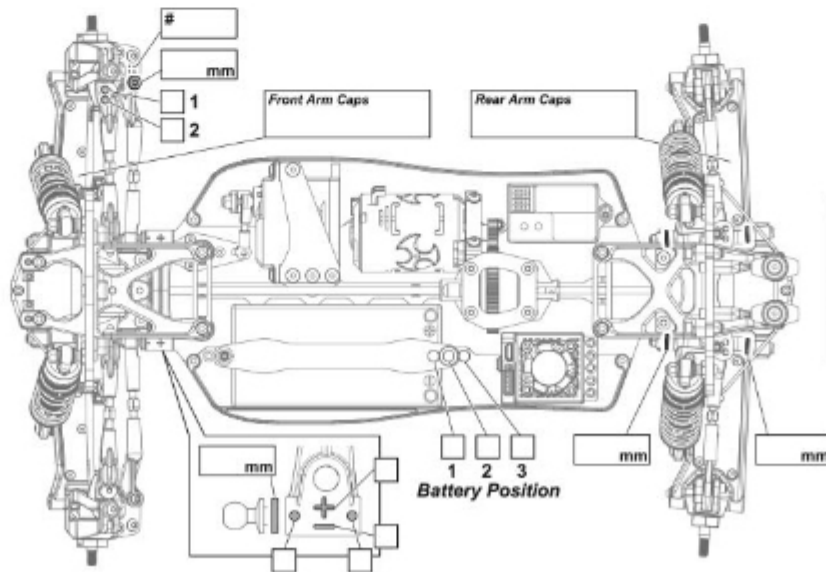

### REAR TOE-IN

R/F	R/R	Toe-in
0.5mm	0.5mm	2.0°
0.5mm	1.0mm	2.5°
0.5mm	1.5mm	3.0°
0.5mm	2.0mm	3.5°

Notes: \_\_\_\_\_  
 \_\_\_\_\_  
 \_\_\_\_\_

$$\text{Gear Ratio} = \frac{\text{Spur Gear}}{\text{Pinion Gear}} \times 3.3077$$

Driver **Standard Setup** Date \_\_\_\_\_ Track \_\_\_\_\_ Event \_\_\_\_\_

Track Condition \_\_\_\_\_

## FRONT

### FRONT KICK-UP



Front/Front	Front/Rear	Kick-up	
•	•	10°	
••	•	9°	
•••	•	8°	✓
•	••	11°	
••	••	10°	
•••	••	9°	
•	•••	12°	
••	•••	11°	
•••	•••	10°	

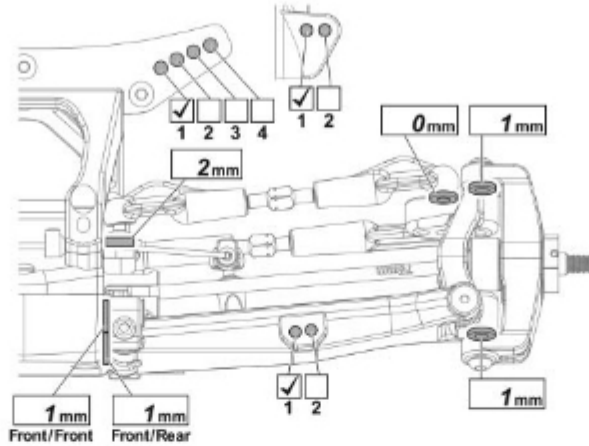

### FRONT SHOCKS

Oil wt.	<b>50</b>
Piston	<b>2 x 1.6</b>
Spring	<b>HB60</b>
Notes	

Ride Height	<b>19mm</b>
Camber Angle	<b>-1°</b>
Toe Angle	<b>1°</b>
Sway Bar	<b>1.2mm</b>
Shock Length	<b>78 mm</b>



## REAR

### REAR ANTI-SQUAT



Rear/Front	Rear/Rear	Anti-squat	
•	•	0°	
•	••	1°	
•	•••	2°	
••	••	0°	
••	•••	1°	
•••	•••	0°	✓

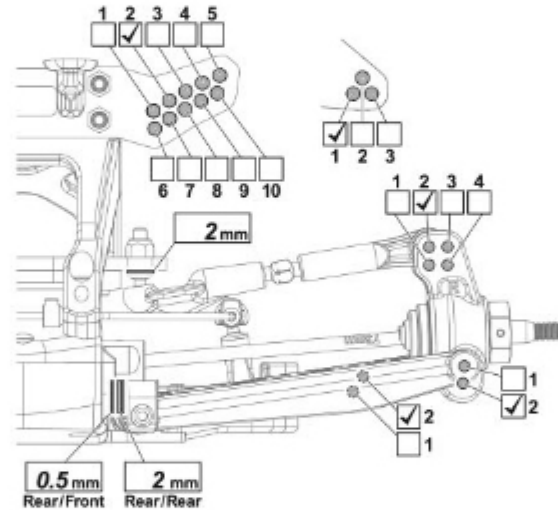

### REAR SHOCKS

Oil wt.	<b>40</b>
Piston	<b>2 x 1.7</b>
Spring	<b>HB35</b>
Notes	

Ride Height	<b>20mm</b>
Camber Angle	<b>-1°</b>
Toe Angle	<b>3.5°</b>
Sway Bar	<b>1.4mm</b>
Shock Length	<b>92.5mm</b>



### TIRES

	Front	Rear
Tire		
Insert		

Battery **Team Orion**  
 Motor **5.5**  
 Gearing **72 | 21**  
 Body / Wing **Std | Std**

### DIFF OIL

	Front	Center	Rear
Brand			
Oil wt.	<b>7,000</b>	<b>30,000</b>	<b>5,000</b>

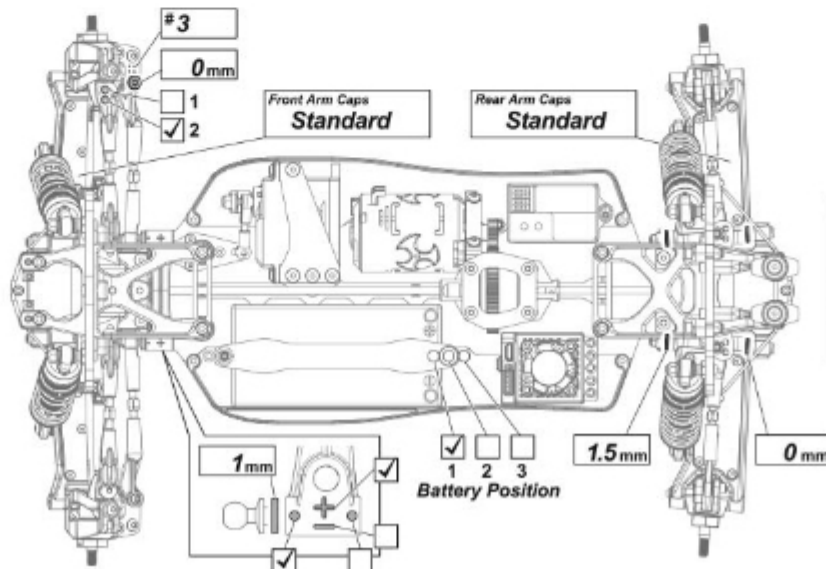

### REAR TOE-IN

R/F	R/R	Toe-in	
0.5mm	0.5mm	2.0°	
0.5mm	1.0mm	2.5°	
0.5mm	1.5mm	3.0°	
0.5mm	2.0mm	3.5°	✓

Notes: \_\_\_\_\_  
 \_\_\_\_\_  
 \_\_\_\_\_

$$\text{Gear Ratio} = \frac{\text{Spur Gear}}{\text{Pinion Gear}} \times 3.3077$$

**EXPLODED  
VIEW**

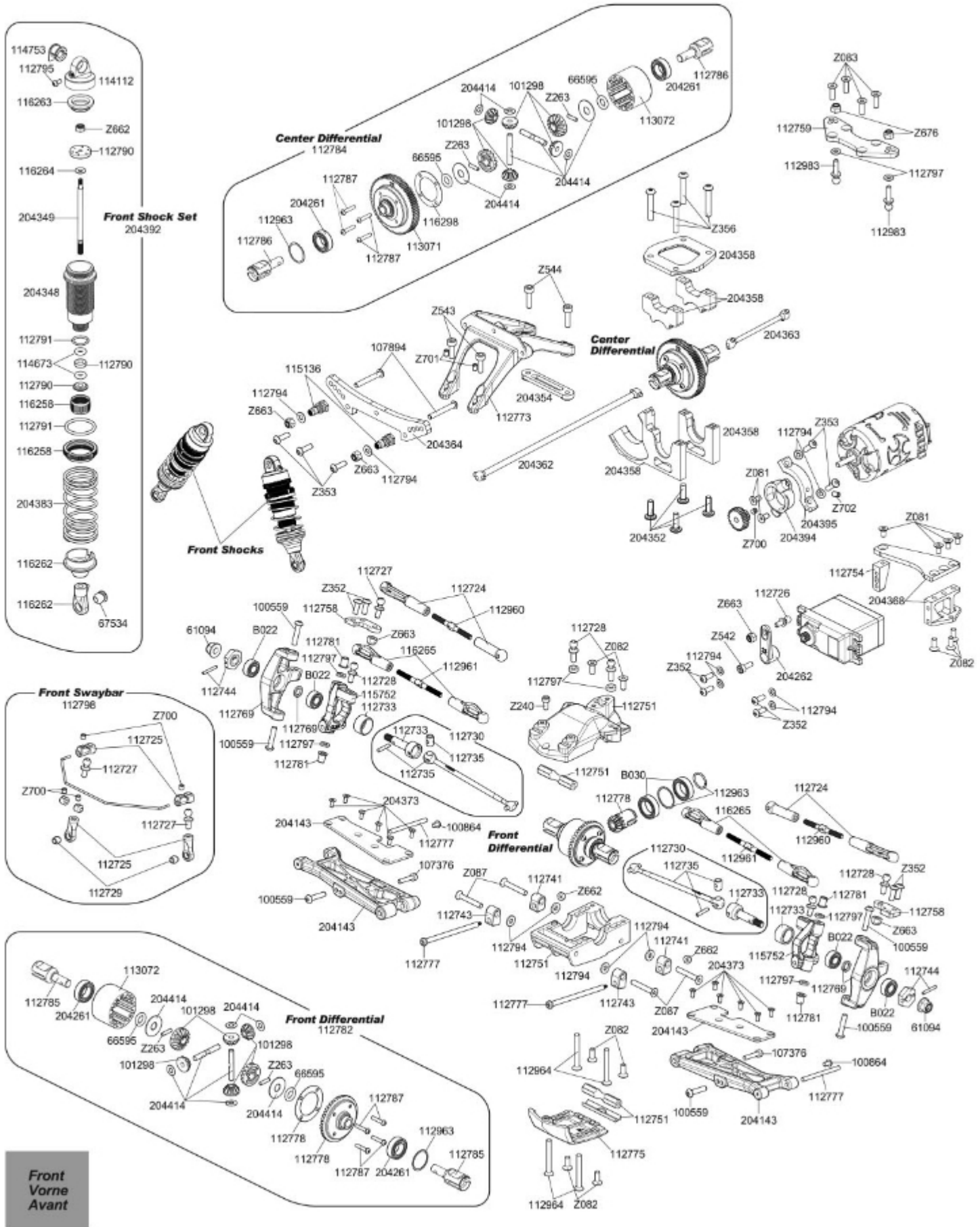

# EXPLODED VIEW

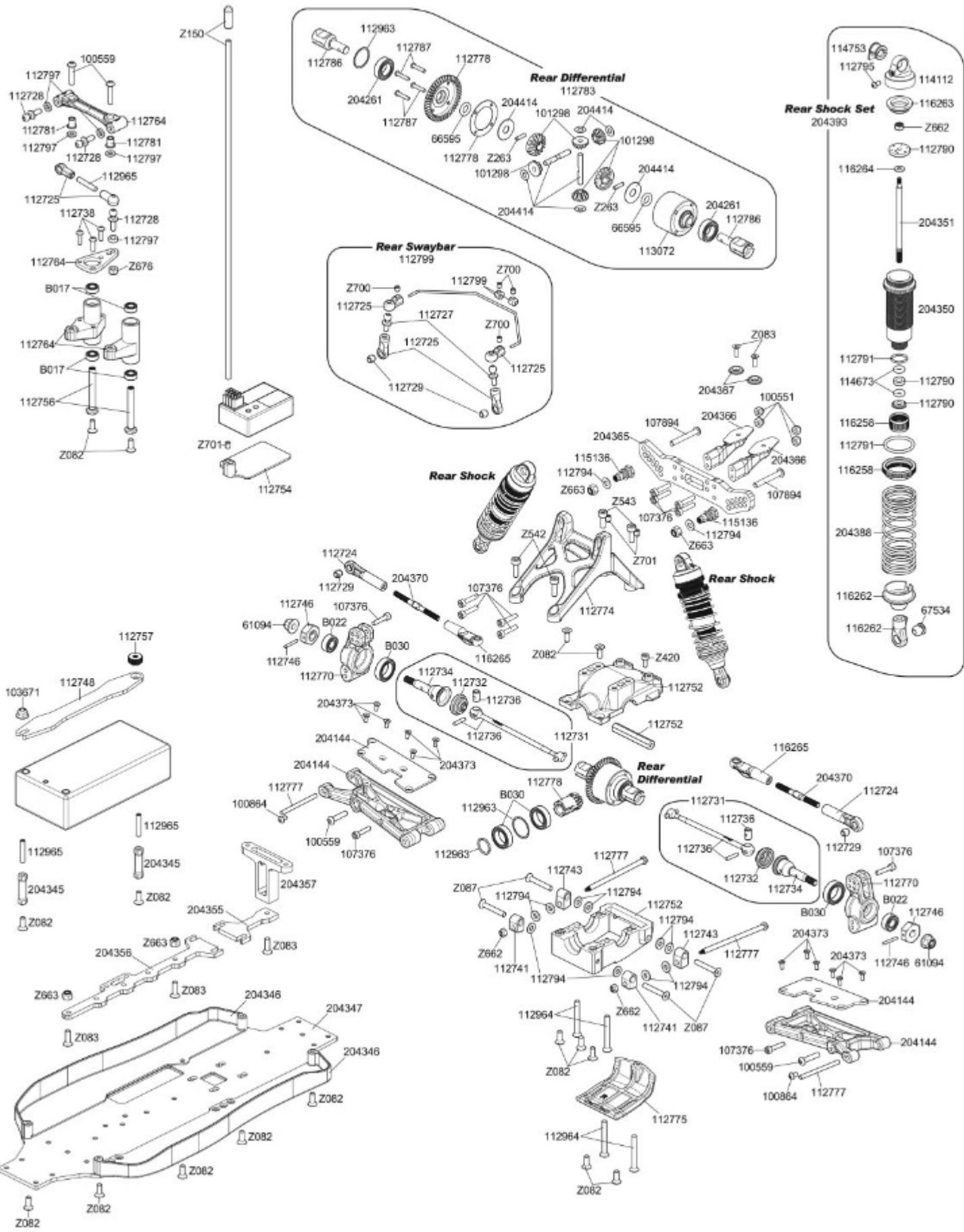



Lined area for notes, consisting of 25 horizontal lines.

# Parts List

## Parts # Description

HB100561	LOCK NUT M2.5 (4PCS)
HB100569	BUTTON HEAD SCREW M3X14MM (HEX SOCKET/10PCS)
HB100864	BUTTON HEAD SCREW M2.5X4MM (HEX SOCKET/10PCS)
HB101290	DIFF. GEAR SET
HB103671	FLANGED LOCK NUT M3 (10PCS)
HB107376	CAP HEAD SCREW M2.5X12MM (10PCS)
HB107894	BUTTON HEAD SCREW M3X22MM (10PCS)
HB112724	BALL CUP SET
HB112725	BALL CUP SET (SMALL)
HB112726	BALL STUD 4.8X4X6MM (4PCS)
HB112727	BALL STUD 4.8X5X6MM (4PCS)
HB112728	BALL STUD 4.8X5X8MM (4PCS)
HB112729	BALL 4.8X2.5MM (4PCS)
HB112730	FRONT DRIVE SHAFT SET 75MM
HB112731	REAR DRIVE SHAFT SET 73MM
HB112732	AXLE BOOT (REAR/4PCS)
HB112733	AXLE (FRONT/2PCS)
HB112734	AXLE (REAR/2PCS)
HB112735	AXLE REBUILD KIT (FRONT)
HB112736	AXLE REBUILD KIT (REAR)
HB112738	BUTTON HEAD SCREW M2.5X8MM (HEX SOCKET/10PCS)
HB112739	FLAT HEAD SCREW M2X5MM (HEX SOCKET/10PCS)
HB112741	ARM MOUNT A (2PCS)
HB112742	ARM MOUNT B (2PCS)
HB112743	ARM MOUNT C (2PCS)
HB112744	ALUMINUM HEX HUB 12MM (FRONT/2PCS)
HB112746	ALUMINUM HEX HUB 12MM (REAR/2PCS)
HB112748	BATTERY HOLDER SET (SHORTY)
HB112751	FRONT GEAR BOX SET
HB112752	REAR GEAR BOX SET
HB112754	SERVORECEIVER MOUNT SET
HB112756	STEERING POST (2PCS)
HB112757	THUMB SCREW M3 (ORANGE/2PCS)
HB112758	ACKERMANN ARM (4)
HB112759	CAMBER PLATE (REAR)
HB112764	STEERING CRANK SET
HB112769	STEERING BLOCK SET (L/R)
HB112770	REAR HUB SET (L/R - D413/D216)
HB112771	1/10 BUGGY FRONT WHEEL (WHITE/2PCS)
HB112772	1/10 BUGGY REAR WHEEL (WHITE/2PCS)
HB112773	FRONT SHOCK TOWER MOUNT
HB112774	REAR SHOCK TOWER MOUNT
HB112775	SKID PLATE SET (F/R) (6PK)
HB112777	HINGE PIN SET
HB112778	DIFFERENTIAL GEAR SET
HB112781	FLANGED BUSHING (4PCS)
HB112782	FRONT GEAR DIFFERENTIAL SET
HB112783	REAR GEAR DIFFERENTIAL SET
HB112784	CENTER GEAR DIFFERENTIAL SET (72T)
HB112785	DIFF OUTDRIVE (TYPE-A/2PCS)
HB112786	DIFF OUTDRIVE (TYPE-B/2PCS)
HB112787	BUTTON HEAD SCREW M2X10MM (10PCS)
HB112790	SHOCK PISTON SET (4X1.2MM/1.3MM/1.4MM/BLANK)
HB112791	SHOCK SEAL SET
HB112794	WASHER SET 3X7MM (0.5MM/1.0MM/ORANGE/6PCS)
HB112795	BUTTON HEAD SCREW M2X8MM (HEX SOCKET/10PCS)
HB112797	WASHER SET 3X6MM (0.5MM/1.0MM/2.0MM/ORANGE/6PCS)
HB112798	FRONT SWAY BAR SET
HB112799	REAR SWAY BAR SET
HB112800	TURNBUCKLE M3 X 34MM (2PCS)
HB112801	TURNBUCKLE M3 X 38MM (2PCS)
HB112803	GEARBOX SHIM SET (6PCS)
HB112804	FLAT HEAD SCREW M3 X 25MM (8PCS)
HB112805	SCREW SET M3 X 16MM (6PCS)
HB112808	BALL STUD 4.8X5X10MM (4PCS)
HB113071	D413 SPUR GEAR (72T)
HB113072	D413 DIFF CASE
HB114112	ALUMINUM SHOCK CAP (HARD ANODIZED/2PCS)
HB114673	SILICONE O-RING P-3 (#30/YELLOW/20PCS)
HB114753	SHOCK CAP BUSHING (4PCS)
HB115136	ALUMINUM SHOCK STANDOFF (4PCS)
HB115752	CASTER BLOCK SET 12.5 DEG (L/R)
HB116258	SHOCK SET V2 12MM BORE SHARED PARTS SET (1 PAIR)
HB116261	SHOCK PISTON SET (2X1.6MM/2X1.7MM)
HB116262	SHOCK EYELET/PERCH SET (2PCS)
HB116263	12MM SHOCK BELLOW BLADDER V2 (4PCS)
HB116264	12MM SHOCK HARDWARE PARTS SET V2
HB116265	BALLCUP SET (6PCS)
HB116298	GEAR DIFF SEAL (3PCS)
HB204083	FOAM ADHESIVE PAD
HB204143	SUSPENSION ARM FRONT (HARD/D413)
HB204144	SUSPENSION ARM REAR (HARD/D413)

## Parts # Description

HB204261	BEARING 8X14X4MM V2
HB204262	ALUMINUM STEERING SERVO HORN (25) V2
HB204345	BATTERY POST (D418)
HB204346	CHASSIS GUARD SET (D418)
HB204347	ALUMINUM CHASSIS (2.5MM/D418)
HB204348	FRONT SHOCK BODY (D418)
HB204349	FRONT SHOCK SHAFT (D418)
HB204350	REAR SHOCK BODY (D418)
HB204351	REAR SHOCK SHAFT (D418)
HB204352	M3 FLUSH FASTENER (10MM)
HB204353	REAR CAMBER MOUNT SPACER (D418)
HB204354	STEERING POST BRACE (D418)
HB204355	REAR CHASSIS STIFFENER (D418)
HB204356	FRONT CHASSIS STIFFENER (D418)
HB204357	REAR BULKHEAD (D418)
HB204358	CENTER BULKHEAD SET (D418)
HB204362	FRONT DRIVE SHAFT 144MM (D418)
HB204363	REAR DRIVE SHAFT 52MM (D418)
HB204364	FRONT SHOCK TOWER (D418)
HB204365	REAR SHOCK TOWER (D418)
HB204366	WING MOUNT (D418)
HB204367	WING BUTTON (D418)
HB204368	SERVO MOUNT SET (D418)
HB204370	M3 X 28MM TURNBUCKLE
HB204371	M2 X 5MM BHCS (1.5MM HEX)
HB204372	M2 X 10MM BHCS (1.5MM HEX)
HB204373	HB M2 X 5MM FHCS (1.5MM HEX)
HB204374	JCONCEPTS D418 BUGGY BODY/SHELL (INCLUDING WINDOW MASK)
HB204375	JCONCEPTS D418 BUGGY WING
HB204380	D418 SPRING (FRONT 60)
HB204388	D418 SPRING (REAR 35)
HB204392	FRONT SHOCK KIT (D418)
HB204393	REAR SHOCK KIT (D418)
HB204394	MOTOR CAM (D418)
HB204395	MOTOR CLAMP (D418)
HB204413	VELCRO TAPE 20X200MM
HB204414	Diff Shaft Set (D418)
HB66595	O-RING P5 BLACK (4PCS)
HB67534	BALL 5.8X5.6MM (4PCS)
HB68017	BALL BEARING 4X8X3MM (2PCS)
HB68022	BALL BEARING 5X11X4MM (2PCS)
HB68030	BALL BEARING 10X15X4MM (2PCS)
HB2081	FLAT HEAD SCREW M3X6MM (HEX SOCKET/10PCS)
HB2082	FLAT HEAD SCREW M3X8MM (HEX SOCKET/10PCS)
HB2083	FLAT HEAD SCREW M3X10MM (HEX SOCKET/10PCS)
HB2084	FLAT HEAD SCREW M3X12MM (HEX SOCKET/10PCS)
HB2087	FLAT HEAD SCREW M3X20MM (HEX SOCKET/10PCS)
HB2150	ANTENNA PIPE SET
HB2263	PIN 2X8MM (12PCS)
HB2307	FLAT HEAD SCREW M4X10MM (HEX SOCKET/THIN TYPE/4PC)
HB2352	BUTTON HEAD SCREW M3X8MM (HEX SOCKET/10PCS)
HB2353	BUTTON HEAD SCREW M3X10MM (HEX SOCKET/10PCS)
HB2356	BUTTON HEAD SCREW M3X15MM (HEX SOCKET/10PCS)
HB2420	CAP HEAD SCREW M2 6X9MM (12 PCS)
HB2424	CAP HEAD SCREW M2.6X16MM (10PCS)
HB2542	CAP HEAD SCREW M3X8MM (12PCS)
HB2543	CAP HEAD SCREW M3X10MM (6PCS)
HB2544	CAP HEAD SCREW M3X12MM (6PCS)
HB2662	LOCK NUT M2 4PCS
HB2663	LOCK NUT M3 (6PCS)
HB2676	LOCK NUT M3 THIN TYPE (4PCS)
HB2700	SET SCREW M3X3MM (6PCS)
HB2701	SET SCREW M3X4MM (6PCS)
HB2702	SET SCREW M3X5MM (10PCS)

# Option Parts List

## Parts # Description

HB112745	ALUMINUM HEX HUB 9.8MM (FRONT/2PCS)
HB112755	SERVO SAVER SET
HB112796	FRONT SUSPENSION ARM SET
HB112797	REAR SUSPENSION ARM SET
HB112798	CASTER BLOCK SET 10 DEG (L/R)
HB112799	D413 BUGGY BODY
HB112803	SUSPENSION ARM COVER SET (CARBON GRAPHITE)
HB112804	ACKERMANN ARM (3)
HB112805	ACKERMANN ARM (5)
HB112825	FRONT WHEEL (YELLOW/2PCS)
HB112827	REAR WHEEL (YELLOW/2PCS)
HB114674	SILICONE O-RING P-3 (#40/ORANGE/20PCS)
HB114675	SILICONE O-RING P-3 (#50/GREEN/20PCS)
HB115751	CASTER BLOCK SET 15 DEG (L/R)
HB115756	ACKERMANN ARM SET (6)
HB204140	M3 NYLOCK NUT (THIN PROFILE) (6PCS)
HB204263	ALUMINUM STEERING SERVO HORN (23) V2
HB204327	HB RIDE HEIGHT GAUGE (15-45MM)

## Parts # Description

HB204382	D418 SPRING (FRONT 55)
HB204384	D418 SPRING (FRONT 65)
HB204385	D418 SPRING (FRONT 70)
HB204386	D418 SPRING (FRONT 75)
HB204387	D418 SPRING (REAR 30)
HB204389	D418 SPRING (REAR 40)
HB204390	D418 SPRING (REAR 45)
HB204391	D418 SPRING (REAR 50)
HB204403	TITANIUM TURNBUCKLES M3X29MM (2PCS/D418)
HB204404	TITANIUM TURNBUCKLES M3X38MM (2PCS/D418)
HB204405	TITANIUM TURNBUCKLES M3X34MM (2PCS/D418)

Serial Number  
Seriennummer  
Número de serie



[www.hbracing.com](http://www.hbracing.com)  
Neidhart SA  
Ch. du Pré-Fleuri 31  
CH-1228 Plan-les-Ouates  
Switzerland  
Phone: +41 22 706 18 50